

FC Fire Company Greenbrier Restoration August 06, 2016

This remarkable story begins with someone sending to me on May 12, 2016, scans of several Corvair 95 window stickers and car shippers for my ECL decoding project (the originals have gone to Dave Newell). Among these was the car shipper for a 1963 8-door Greenbrier sold to the Malden West Camp Fire Company in Saugerties, NY. It was a very interesting FC, with an optional (but non-RPO) engine. Twelve days later, my good friend Ed Bittman emailed that he has spied several Corvair cars and FCs on Craigslist in a neighboring Florida city, which he soon visited and dutifully reported back the FC VINS and data plate codes. Incredibly, one of them is the Malden West Camp Fire Company van! After some tough haggling with the owner, we decided to buy it. Ed made the initial purchase, and then sold it to me. I just had the van flat-bedded to Marietta, OH.

Although the van may have seen some challenging times, it is in exceptional condition, as you can see in the pictures, it still has the original paint and most of its service lights, having lost only the beacon light and siren. Only a couple of dents, essentially no undercarriage rust; it seems to be solid. There must have been a two-way radio originally, but that also is missing. The engine is in very rough shape, but more about that later.

This is the only extant Corvair 95 that I am aware of with an existing shipper or window sticker. A contact I have in Saugerties has provided some valuable backstory.

A painting based upon a photograph of the van being

presented to the Fire Company still hangs in the fire house (see pic below), and shows some details of the original outfitting. The van serviced the community from 1963 to 1986 when it was decommissioned and sold. The NY inspection sticker on the window is dated 1995 and suggests that it



The van was flatbedded from FL to Marietta, OH, about a 18 hour trip

remained road worthy until then. It was reportedly obtained from a junkyard sometime in the early 2000s, and then transported to Florida. If anyone knows anything about the history of this van, please let me know.

The odometer reads only 15882 miles.

Delivery of the Firebrier to Marieta: We rendezvoused at around 10PM



After some tricky negotiations into a very tight alley, the van was winched into my garage. My other 8-door is feeling very depressed right now, having been relegated to a storage facility



This is the painting of the van when it was presented to the Fire Department.

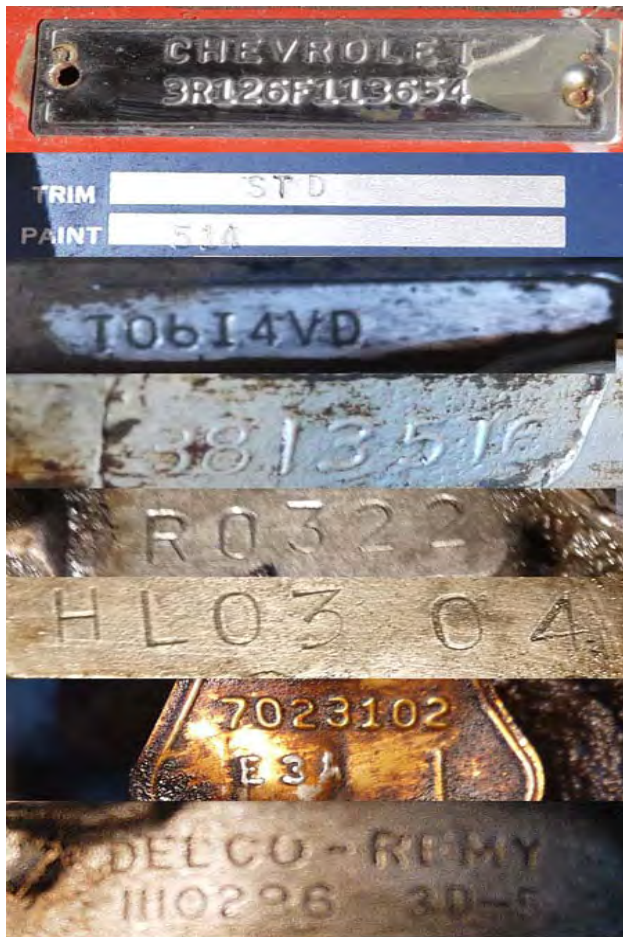

These are the various codes
 VIN: 3R126F113654 – a late June 1963 assembly in Flint, and delivered to the dealership in June; It was presented to the Fire Dept dated 9-4-63, presumably requiring 2.5 months to be outfitted for its Emergency Vehicle duties.

Paint code: 514 – solid Cardinal Red
 Trim code: std – standard trim

The various codes indicate that the powertrain is original and unmodified (other than by the elements).

Engine code: TO614VD - an FC 102 HP engine assembled June 14. The 102 HP engine was never an RPO and not an ideal power-plant for the heavier FC, but obviously it could be a special order, and there have been other reports of 102HP engines in Corvair 95s.

Heads: 3813516 – 63 102 HP

Transmission : R0322 – 4 spd, though I'm not sure how this fully translates.

Differential: HL0304 – 3.89 positraction

Carburetors: 70231002 E3A – 1963 102HP, first modification, May 63,

Distributor: 1110296 – 1963 super turbo air



Visually, the engine is in very rough shape, it is caked in silt and debris, and may have been inundated in a flood. Disassembly will show the actual state of affairs, but a cursory inspection shows dirt but little rust. The pre oil bath cleaner, listed in the car shipper, is still present.

The interior is in good shape. Originally there was a second bench seat, but that has been lost.



The plan is a full restoration back to the original condition when it was a serviceable emergency vehicle. I will be posting the story of the restoration as it proceeds.

August 07 2016

The Fire Compan FC engine has been partially disassembled, with all the upper components and the engine shrouds removed.

Many of the rubber components are in remarkable condition; the firewall heater duct seal is still soft and pliable. (If rear doors weren't being repainted, weatherstripping could be left in place.)

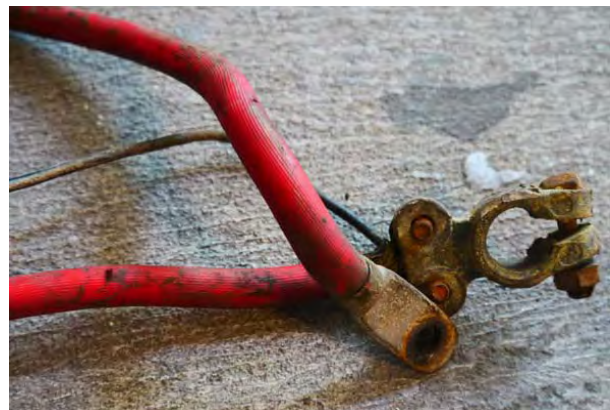

The battery cable is unusually stout. Was this necessary with the 35 Amp Generator?

Stripped down to the shrouds and vacuumed to remove as much silt and other aluvial deposits as possible.

With the top shroud removed, sediment underneath was revealed

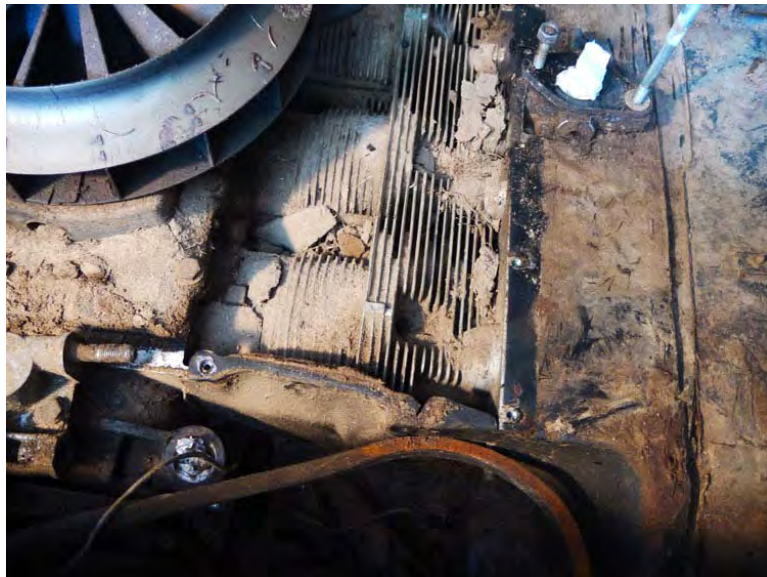

All the shrouding is in excellent condition, including the engine weather strip retainers, which are often rusted. (But Darn, there's a lot screws securing the shrouding! Did the engineers intentionally use different size screws just to make finding the correct size socket so annoying?)

While removing the shrouding I discovered this piece, located along the engine front edge. I've never seen this before, and at about 2 inches long, is it the smallest piece of shrouding ever made?



Here's the engine exposed and vacuumed clean (more or less).



Next steps will be to remove the oil pan and crankcase cover, examine the condition of the connecting rods, and then drop the powertrain. There is only a layer of greasy scum in the oil pan. The engine arrived with the spark plugs and the valve covers removed, and this has left the rocker arms, push rods, etc. well oxidized. I've been researching past Forum threads on removing rusted head nuts.

I'm hoping for the best for the crankcase and heads. Hurray for aluminum.

There is an extra foot switch on both the driver and passenger sides of the cab.

Here's the driver side. I assume they are for the siren.



And here is the wiring to the siren foot switch on the Driver side. I have not yet traced the wiring yet to find the relays, etc. Thanks for info about what to look for.



August 08, 2016

The crankcase cover and oil pan have been removed, revealing unpleasantness.

- 1) Damage to the crankcase vent assembly over rods 5 & 6
- 2) But no visible damage to rods 5 & 6

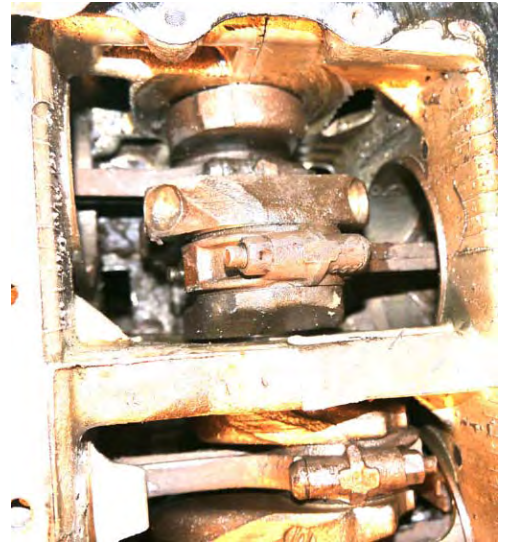

- 3) A hole punched through the bottom of the crankcase left side below rods 5 & 6
Oh, and by the way, can this be repaired through aluminum welding?



The oil pan seems to have taken a trip through the LeBrea Tar Pits -- it was packed with sludge over an inch thick in some places.



A careful excavation found no extinct mammals but did yield a multitude of foreign objects. These include small pebbles and a variety of metal pieces, mostly contorted sheet metal

It seems that a foreign object shredded the sheet metal of the crankcase vent assembly. The metal pieces were battered about violently enough to punch a hole through the crankcase. I hope to soon know if there has been any other damage.

August 09, 2016

Further work on the Fire Department Emergency Truck is good-news, bad news.

The power train was pulled with little problem

Separating the front end shows the clutch is in bad shape. Seems to me to be rusted beyond reprieve? Ditto for the starter

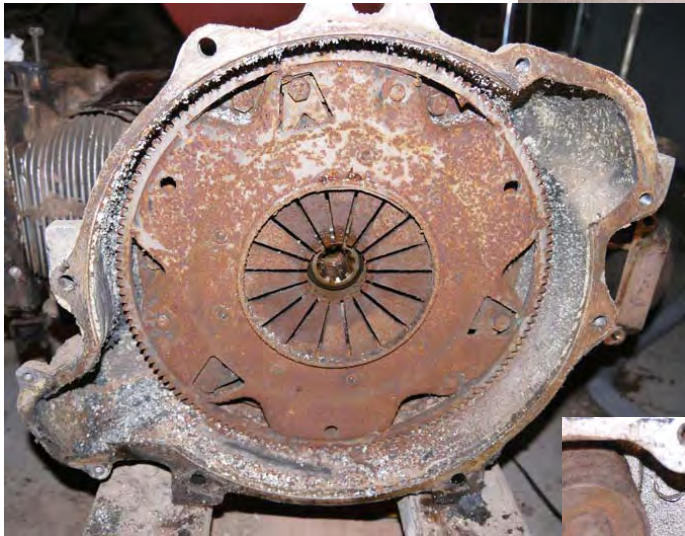

The rocker arms/lower cylinder head nuts came off very easily, and revealed push rod tubes containing more (much more) than just push rods.



The upper cylinder head nuts and the ends of the bolts were seriously rusted. I tackled these with serious heat, and lube. I used my Smith mini-torch, which used map gas and O₂ (I've got it connected to a large O₂ cylinder).



The head bolts were locked in place as best possible with a vice grip and other apparatus to prevent rotation. After torching the nut for 1-2 minutes, it was sprayed with a penetrating lubricant and then ratcheted off. Sometimes the nut had to be reheated 2 - 3 times.

11 -12 nuts were removed successfully, one bolt unscrewed from block (I'll replace with over-sized one). And what did I find when the heads were pulled...? Three of the pistons have holes in them, like this



Miraculously, the heads are undamaged, I'm planning to fully replace the valves and springs when the heads are serviced, but hoping the seats can be retained.

So what would cause holes in half the pistons? I've heard that detonation will do this, but in three? I'm pretty sure that it was metal from the pistons that damaged the crankcase vent assembly and the block. Fortunately, I see no other damage to the crankcase. The pistons were seized in the cylinders, but after I removed the cylinders the crankshaft could be rotated with a ratchet on the pulley nut.

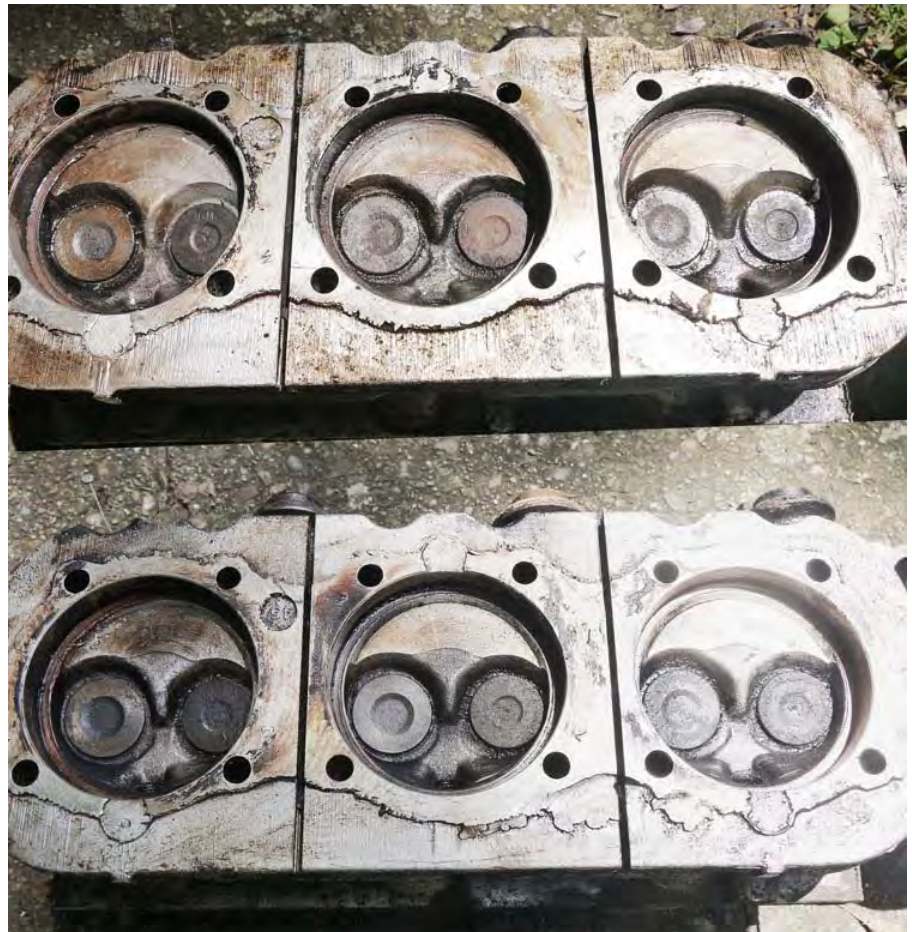

August 10, 2016

THE KINGSTON DAILY FREEMAN, KINGSTON, N. Y., TUESDAY EVENING, APRIL 27, 1965

Fire Damages Van Buskirk Building, Store

An elderly woman was rescued and another family evacuated late Monday afternoon from the burning Van Buskirk building at Main and Partition Street, Saugerties.

Mrs. Agnes Van Buskirk, about 80, who lived in an apartment above the empty store was assisted to the street by Robert Speirs and Patrolman John Pavlak. The John Kolano family was also evacuated before the thick smoke coming from the basement and rear of the floor reached the upper rooms.

Patrolman Pavlak said that when the fire was noticed about 5:40 p. m. someone on the street said that Mrs. Van Buskirk, widow of Herbert Van Buskirk was in the upstairs apartment and would have trouble getting out. Speirs rushed up the stairs and assisted the woman out of the room which started to fill with smoke. Pavlak close behind Speirs assisted in the rescue.

Mrs. Van Buskirk was taken to Dale's Sanitarium.

The three-story brick and stone building consists of an empty store, which formerly housed Paramount Pharmacy, and apartments on the second and third floors.

All four units of Saugerties Fire Department responded to the scene. Centerville Fire Company was called through Mutual Aid for standby duty in the event of another fire. Malden-West Camp Fire Company emergency truck was also called to the scene.

Officer Pavlak said the fire apparently started in the basement and swept into the rear of the empty store where considerable damage was reported.

Kenneth Barnes, proprietor of Paramount Pharmacy and Department store next door said there was some minor smoke damage in his store and that some merchandise and fixtures belonging to him were damaged in the empty store.

Thanks to Paul at Winvoices.com for sending the following very cool clipping. See Paragraph six.

Here's some other pictures of the damaged pistons. For all three damaged pistons, the crown has been blown downward, which is clearly shown here



This is the rear; again, punched down from the combustion chamber. I see no damage to the connecting rods



So what would cause this type of piston damage but leave the heads undamaged??

August 10, 2016



Additional progress today on engine disassembly - and repair!

Removed the flywheel (torched the retainer ring around each rusty bolt head before removing), bellhousing, and engine rear housing. Some of the channels of the rear housing have a white powdery deposit. Does anyone have suggestions for the best way to clean this?

Split the crankcase; crankshaft looks good; still covered with oil, but camshaft is dry and some cams show surface rust - I'm assuming this will need to be replaced

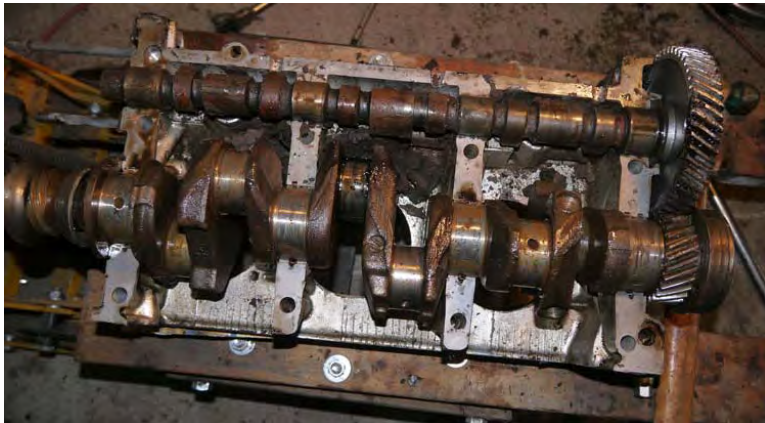

Lots of dried muck around camshaft and lifters, which were seized. I had to tap, sometimes firmly, to get lifters out.

QUESTION: What should be done to the camshaft journals and lifter bores before assembly?

Here's the damaged crankcase half cleaned up. I saw no other significant damage.



CRANKCASE REPAIR

A local welder made the repair today, said it would be straightforward, but with precautions. Because of the way it broke, the piece could not be simply fitted back in place. Both surfaces were ground to clean and create a 'V' space for welding. It was decided to weld only on one side (the bottom)- further from the camshaft journals and lifter bores. I asked for strength not aesthetics - no one will see the weld



And the top, unwelded surface. The mating edge was ground flat.



August 11, 2016

Closer inspection shows that the crankshaft has some scoring, and as per the discussion on the Engine Bearing thread, it needs to be turned or replaced.



I've decided to have it turned. My machine shop guy says the staining of the main journals is evidence of moisture (I never mentioned likely engine flooding), which he said also necessitates a regrind. Plan is for a 0.01 or 0.02.

I believe that the consensus on the Engine Bearing thread is that the stock main bearings in this engine are copper.

I'm not sure if these are still available (other than the NOS on ebay)?

Time to create a parts list.



August 12, 2016

Today I found the differential and transmission... under mounds of gunk! I cleaned them enough to open without dropping tons of crud inside.

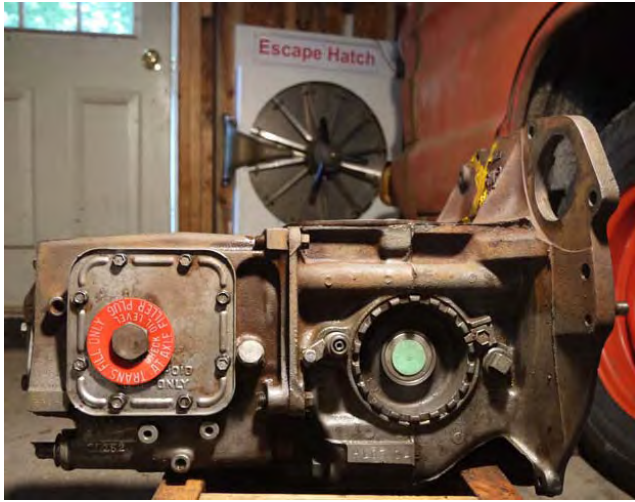

Can anyone identify in the following pictures the big yellow 'X' on the differential carrier case, the metal tang on one of the differential cover bolts, and the letters "C67" painted on the differential ring gear?

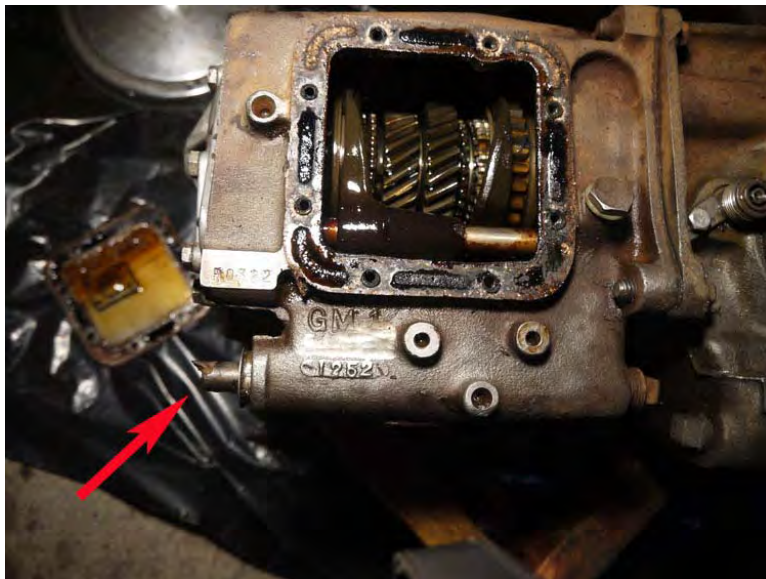

There was plenty of oil in the differential but little fluid in the transmission. But overall, both look OK, and can be turned by hand. The end of the selector shaft is broken, and this will need to be replaced.

My plan is to have both disassembled as necessary to clean and inspect.

August 14, 2016

Shrouding and other parts have been degreased. I have a deep 20 gallon container of "purple power" degreaser that everything goes into overnight. Great stuff, overnight soaking loosens most paint also. At my local supplier, a 5 gallon container costs \$22.50.

Here's everything ready to go; the top shroud wouldn't fit into the container. 43 items overall, mainly shrouding, but a few other items as well. Oops, make that 44, added the blower pulley.

All are in pretty good shape, at most some surface rust. All these parts will be blasted and powder-coated ASAP; I don't want to let them sit around in the Mid-Ohio valley too long (current humidity: 81%) and further rust.



August 20, 2016

Progress has been made. The front and rear suspensions have been removed, disassembled, and sent off to be blasted and epoxy primed. I couldn't have done this without help from my brother John, visiting from NJ, and providing free labor. We find two brains help to avoid making dumb mistakes. Thanks again Judge!





Rear suspension ready for removal. Brake flanges and axle yokes came off without too much trouble, as did the bolts holding the rear crossmember to the undercarriage.



Front suspension under way. Like everything else, covered with undercoating and caked with rock-hard mud; literally had to chisel some off. Spring extraction went well; had to cut off shocks at bottom.



Front crossmember removed. The bolts holding to the undercarriage were extremely difficult to remove, but they succumbed without incident.



a
it

I rented a control-arm bushing removal press from the local parts store, which was helpful, but lacked the appropriate sized tools. John and I figured out the best way to remove the bushings as we went along, and I fabricated the needed tools. As shown below, we found the easiest method was to first remove the inner part of the bushing. We put the control arm in a vice (1), cut off the exposed rubber bushing (2), then torched the bushings (3) until the rubber melted and it could be pulled out with vice-grips on the center sheath (4 & 5). The control arm shaft could usually then be removed, leaving only the bushing casings to be pressed out.

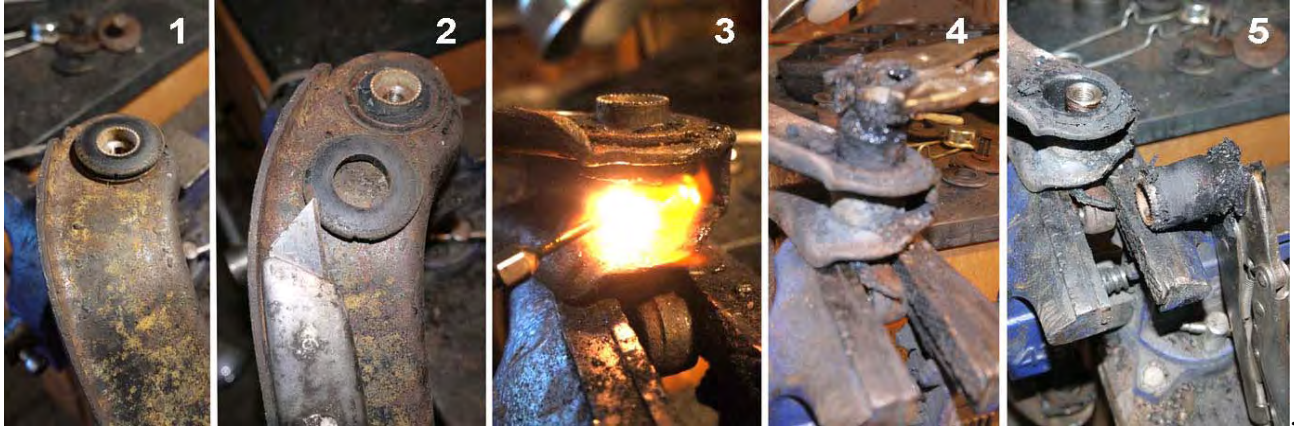

We made a tool to press out the bushing casings by bolting together 13/16" and 15/16" sockets. The larger socket pushes against the bushing casing and the smaller socket acts as an inner guide to keep it aligned.



This tool was used with a custom made receiver (cupped shaded tool) into which the bushing casing was pressed.

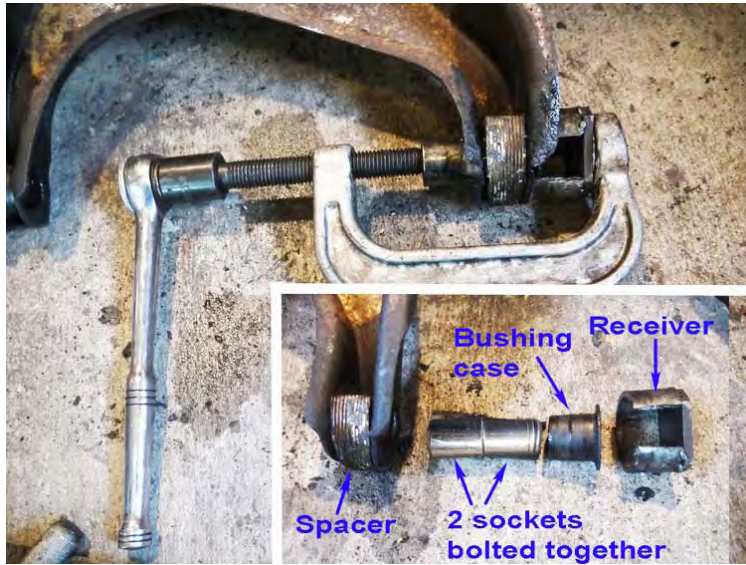

The receiver was made from steel pipe expanded to a diameter just larger than the bushing casing flange, onto which 1/4" steel was welded. Support spacers were used to prevent crushing of the control arms around the bushing. Between the initial torching of the bushing, and some generous use of penetrating oil, the sheaths were easily pressed out.

The ball joint rivets were drilled out - a slow process when making sure to keep the hole centered.



After 2.5 days, everything was disassembled and ready to go. Everything was sent to be blasted except the control arm shafts, which I'll prep myself.



August 21, 2016

With the suspension removed I've looked more closely at an unusual feature of the rear undercarriage. What I thought was jacking damage seems to be something more insidious.

I had noticed earlier this bend to the rear cross support near the right side jacking position, viewed here from the rear:



and here from the front:



With the under coating removed, I can see there is some significant distortion of the undercarriage:

There is something similar on left side, though without as significant change to the surrounding undercarriage.



Here's two more images.

I'm trying top envision how/if this would impact wheel alignment? I'm not seeing that there is a significant change to the positioning of the rear crossmember and the transmission mounts, and any minor change should be corrected with alignment shims, no?



August 22, 2016

A lot of work on the undercarriage is needed - removing all the electrical and mechanical cables, gas tank, etc; stripping the undercoating and fixing a few rusted areas. Lacking the luxury of a rotisserie, and with limited vertical garage space, I want to have the van raised as high as possible. Maybe it's unwarranted, but jack stands make me nervous when working for long period of time under a vehicle. When I do use them, I always place stacks of wood blocks as a fail-safe.



So I've decided to rest the van on supports made from 4 x 6 wood blocks, 16" X 16" on the base, tiers interlocked with 3/4" plywood side panels, and ~20 tall. (additional side pieces were added after these pictures were taken)



August 25, 2016

Well, this is what can be salvaged from the powertrain (click on image for larger view):

Add the distributor and valve covers (forgot to include them), delete the oil pan (has stripped plug hole). Both the crankshaft and camshaft had enough damage to warrant replacement. Actually, the jury is still out on the generator - I'm expecting a rebuild will be necessary.

I suspect many people are thinking, just scrap the whole Darn thing and get an entire new rebuilt engine - and that would probably be cheaper. However, it is my intention to restore this Greenbrier to its original condition.

Fortunately, the critical coded/dated parts - heads, crankcase, transmission and differential -- all seem to be in good condition.

I'm up at the DACC Homecoming and the coded/dated parts are going to Ken Hand, who will be reassembling the short block, rebuilding the heads, and cleaning and checking out the front end of the powertrain.

I'm also shopping around for other stuff - and selling DragFree cross shafts (hopefully).

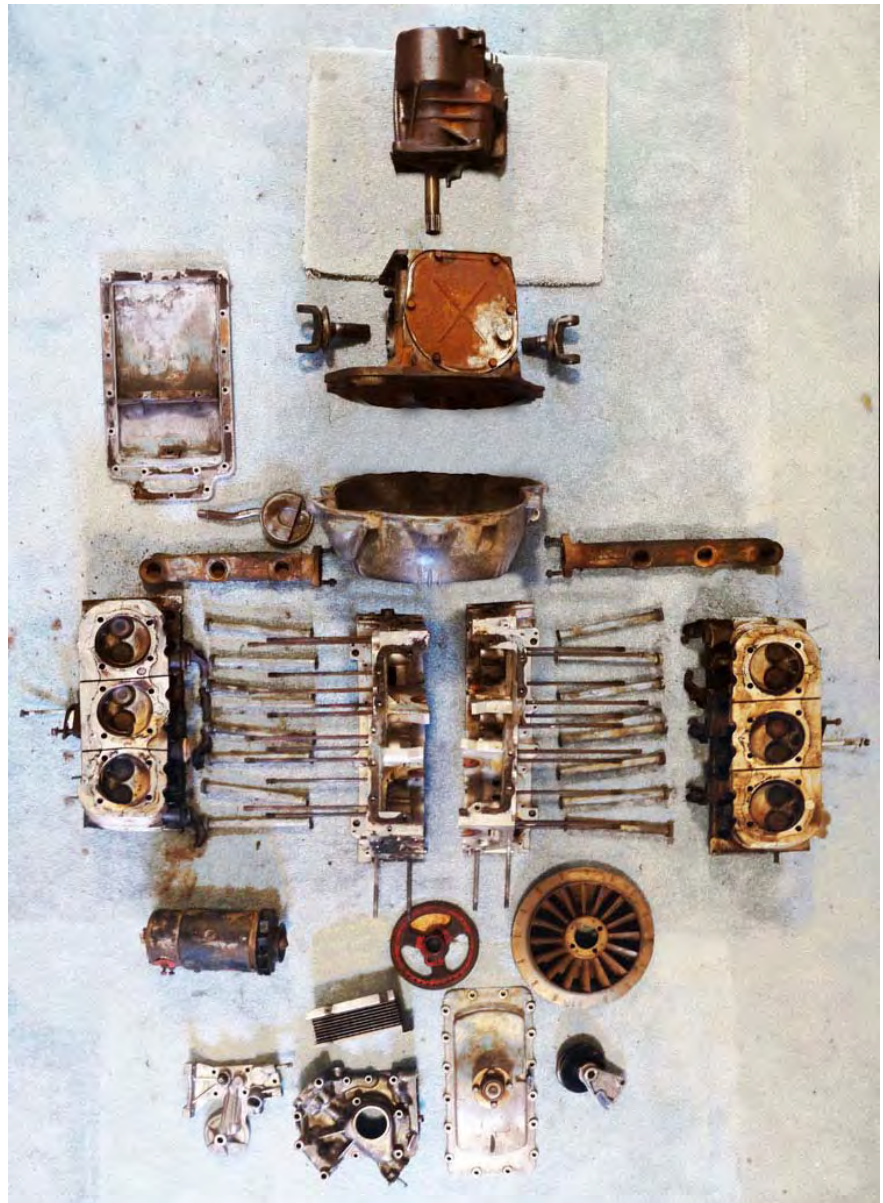

August 31, 2016

Finished clearing all components and cables from the undercarriage. This FC was mud-wasp heaven; fortunately only the mud remains. And fortunately, there are no remaining systems left to be found unrestorable, like the gas tank and the master cylinder.

The absence of fuel in the gas tank was explained by the huge hole in the top.



And the master cylinder is rusted and blistered inside.



Both are junk.



The undercarriage looks really well protected by undercoating below the front cowl ...

In the wheelwells





All around and over the brake and clutch pedal pivots ...

There seems to be a fair amount of exterior paint overspray down here. OK, I haven't removed the steering gear box yet; I'm saving that job for later.

Over the entire center undercarriage and rocker panels ...

Pretty much everywhere except ... above the gas tank, of course!



And here we see some unmolested undercarriage paint. Dark brown with faint overtones of green. Help in identifying this paint would be much appreciated.

I've been testing different ways of removing the undercoating, and although there is no easy way, I have worked out a system that seems to work pretty well... Coming soon to a Forum near you!



August 31, 2016

Suspension parts have been blasted and epoxy primed:



After reinstalling bushings and ball joints, all of these parts will be painted flat black with John Deere Blitz Black. Since I've left the epoxy untop-coated for quite a while, I'll lightly sand it before painting.

Parts that were originally unpainted, such as brake flanges, drums, etc., and assorted other items (shown here blasted) have been painted with SEM self-etching primer. These parts will be painted to match their original metallic appearance (as best possible). I've decided to use Eastwood "Spray Gray" on the cast steel parts, and "Detail Gray" on the stamped parts.

Parts that were originally unpainted, such as brake flanges, drums, etc., and assorted other

September 17, 2016

Today started to put finish coat on the suspension. Space is tight in my garage, so the plastic walls of the "paint shop" need to be rolled down and a fan placed in the window. Here's the rear crossmember painted.



September 26, 2016

Undercoating is coming off the Firebrier. There's no simple one step way to make it disappear, and the Firebrier is good test for different ways to do it. Almost all of the undercarriage and most everything connected to it are pretty well covered. And the undercoating is still well attached!!



And below is a composite image looking into the left rear wheel well. (The compositing did some weird things to the background)

For example, here's looking up at the bottom of the cowl, which is very well protected by undercoating



This FC is so well undercoated, even the compartments behind the wheel wells (eg., the battery compartment) are coated. I tried all sorts of ways to get it off, including just torching it and scraping off, but that was an arm killer, from exertion and occasional assault by molten tar. I read online somewhere about using a vibratory (multi-) tool

It's important to use unserrated blades with the tool to avoid damaging the metal. Since I liked the size of some of the serrated blades, I simply ground off the teeth.



Here the same area after being multitooled:



The multitool does not remove all the undercoating, but certainly the bulk of it. And there are areas that cannot be reached with the tool, and these required brute force heating and scrapping with a stiff putty knife. Any remaining undercoating needs to be removed with stripper and solvent. I start with aircraft stripper - wear a respirator and arm-length rubber gloves (available at HF) when using this stuff. I found the "odor-free" type actually worked better than the regular formula. Aircraft stripper works slower on undercarriage paint. The paint softens and dissolves, but does not bubble up. Give it 5 - 10 minutes to work. If you're going to do this right, going to bare metal in most areas is important to assess where and how much rust is present, and dealing with it before repainting.



September 26, 2016

Here's a suggestion about removing fuel and brake line clips. These single or double-sided clips (originally green) are found along the undercarriage. Exact replicas are not available, as far as I know. The ones sold by Clarks attach to the undercarriage differently than the original, so it's nice to retain and restore the originals if possible. Unfortunately, the clips often break when trying to remove them.

After several attempts, I came up with a tool that removes the clips intact. The tool is made from HF needle nose vice grips to which a washer was welded. The washer was then cut in half and ground to reduce the diameter of the center hole. This hole should have a diameter slightly less than the clip retainer. The tool slips behind the clip, compresses the retainer so that the clip can then be pulled off intact.

btw: Does anyone know why the number "24" would be printed on the inside of the left rear quarter panel, inside the wheel well?

This was found beneath the undercoating. It is painted quite resiliently.



October 15, 2016

So other projects... The suspension is almost ready for reassembly. Had a real bugger of a time pressing in the bushings on one of the front lower control arms; all the rest went in fine, but for whatever reason, the two sleeves were slightly out of alignment and the bushings would not go in. Ended up warping the sleeve rims beyond repair and gave up; got a replacement from the Corvair Ranch (bushing went right in). Here's the front suspension



Still deciding whether the springs will be black or metallic, but I think they'll be metallic with appropriate color stripes. As you can see, brakes also have been rebuilt. Flanges and were blasted, primed, and painted. As previously mentioned I'm using Eastwood "Detail Gray" on the stamped steel parts (such as the flange) and "Spray Gray" on the cast parts (such as the steering knuckle control arms).



Complete rebuild of the brakes themselves; and new front wheel bearings. Found exact match for the cylinder to brake pad rods at the local NAPA (the car rods are different). The only parts reused were the emergency brake components and the automatic adjuster screws, two of these needed thorough derusting and cleaning.

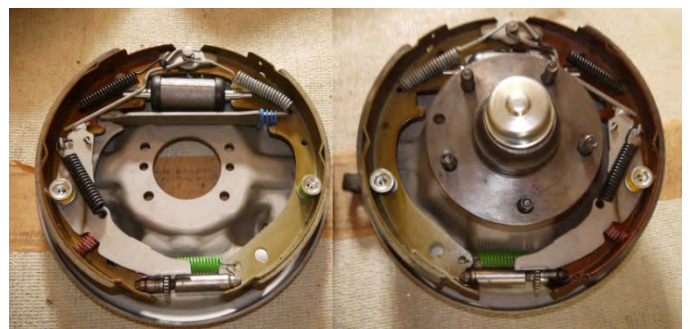

I've also been restoring the air heater assembly. I was inspired to do a complete disassembly and rebuild by a previous Corvair Forum thread. Here's before and after images.

The unit was in really rough shape. The large baffle would barely move.

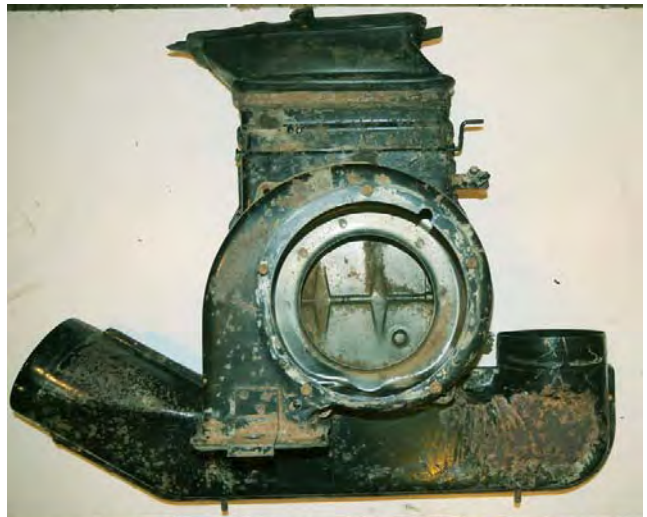

The two halves of the heater were separated using a 5/16" spot-weld drill bit, cutting the weld on the top side of the assembly. Inside: no wonder the baffle wouldn't move. Everything was derusted in my electrolytic deruster, power wire-brushed clean, and bead blasted where necessary. Fortunately, the rubber seals around the baffles were in excellent shape, and were carefully protected during cleaning.

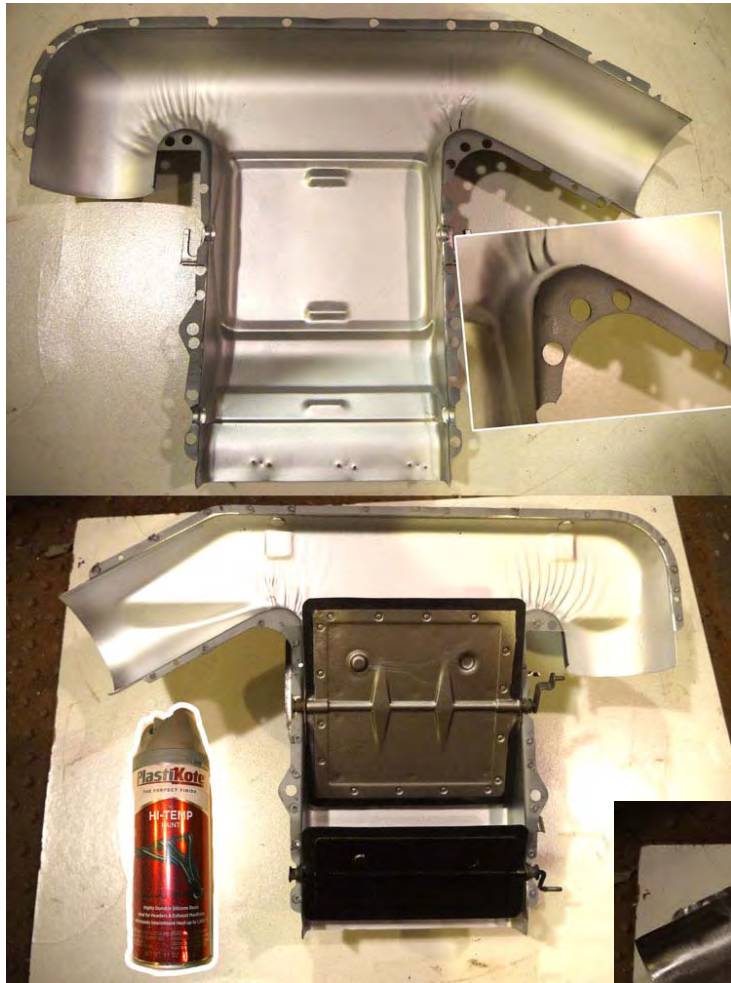

The really tricky part of the deal is painting the inside. It wasn't originally as best I can tell, but parts flash rust here in the mid OH river valley within hours, so painting is a must. Painting the inside after reassembly is not possible because of the baffles, but if painted beforehand, most paints will bubble and peel when the unit is welded back together (heat transfers very quickly through thin gauge steel). My solution was to paint the inside beforehand with Krylon Hi-Temp paint, which I had previously found withstands moderate welding temperatures. Here is the unit ready to be reassembled, Krylon-ed inside (and oven cured at 300oF for 3 hours) except for the edge flanges which were coated with SEM weld-through primer.

As in the original, the small baffle is painted black. The large baffle was also originally unpainted, but because of concern for the rubber seal, oven curing the Krylon wasn't an option, but also not necessary, so I painted it with "stainless steel" enamel.

Everything was clamped and original spot welds were carefully rewelded and ground smooth. I rewelded moving to different locations to avoid heating any area too much. I saw no damage to the Krylon afterwards.



After smoothing the welds and final cleanup, the box was primed with SEM self-etching primer and then painted with a satin black enamel to match the original. Although not shown above, the paint on top of the unit was in excellent condition, so I had it matched at the local paint shop.



October 26, 2016

Most of the heater ducts were made of a resin fiberglass, which fifty years later has become brittle, with edges broken or cracked. Overall the Firebrier ducting is in good shape, though dirty, showing evidence of rodent nesting, and, of course, covered with undercoating. The rear upper duct needed some work, and after everything was thoroughly cleaned restoration was done.



The box had a felt lining which almost always is deteriorated. Clarks, sells a replacement, but the duct top and bottom must be separated to apply it. This can be done after removing several "U"-nuts and drilling out the rivets, a precarious undertaking due to the fragility of the fiberglass. My duct separated well, but in several locations (such as shown in the image inset) the fiberglass along the edges had broken off and needed to be repaired. I patched damaged areas with epoxy impregnated Kerdi membrane. I had the Kerdi membrane left over from a bathroom shower installation. (I have enough for 100 heater ducts, so if you want some let me know.) This is excellent for this application because it is stiff enough to span a gap even when impregnated with epoxy. I used Devcon epoxy, though most any type would probably work. Normally, I simply colored the membrane black with a felt marker before installing, but left it uncolored here to show the pieces.

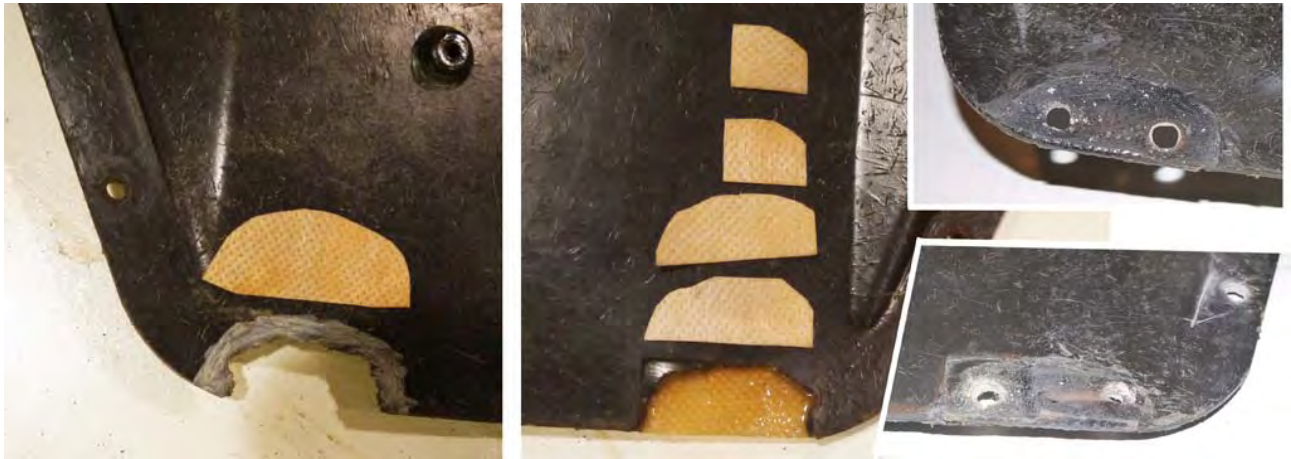

The edges around the hole to be patched were ground down slightly with a dremel tool to assure secure bonding and allow for a level surface. After applying the first piece on one side of the fiberglass and allowing to cure, several additional epoxy impregnated pieces were used to build up the needed thickness, using shorter pieces to recreate the recesses for U-nuts, where necessary. After everything hardens, some sanding and filing finishes the job. Top and bottom of a finished patch is shown on the right side.



The instructions for installing the replacement felt are provided by Clarks. Pretty simple, cut to size and glue in place. The glue provided appears to be standard contact cement. The original screws are not needed, but I installed them anyway - though it is difficult to get them through the felt.

I considered re-rivetting the duct, but could not find an exact match for the original rosette rivets, and feared inflicting damage to the fiberglass when compressing them.

So I opted for Chicago screws that fit into matching threaded inserts and look very similar to rivets. I redrilled the holes slightly larger, at 13/64. Made of aluminum, these screws will not rust.



Here's the restored duct, still needing replacement U-nuts

In their instructions, Clarks suggests caulking between the top and bottom halves. I opted not to; the unit fit back together pretty well, and I feared that caulked together, the duct might never come apart without breaking. I wanted to make sure that this duct could be restored again in 2066.



November 06, 2016

A progress report on undercoating removal.

As you may recall, the Firebrier was well protected with undercoating.

As best I can tell, it was undercoated at both the factory and dealership.

So far, the undercoating has been cleared from the back half of the van, up to the cross sill behind the gas tank, and the metal prepped for painting.



After removing the undercoating as previously described, the surfaces were washed and scrubbed with POR-15 Marine Clean degreaser, rinsed and wiped down. Next POR-15 Metal Prep was applied, which further cleans and etches the surface. The metal was rinsed again and allowed to dry. Metal prep also leaves a protective phosphate layer, and I found that places where this

didn't form needed further cleaning, not an uncommon problem in nooks and crannies of the rocker panel outrigger areas. Wire brushing with 100% isopropyl alcohol worked very well for this touch up work, since it evaporates with no residue.





Removing and cleaning the body bolts separately helped.



Here's the upper realm of one of the wheel wells.

And the powertrain compartments



Any areas with surface rust have been spot painted with POR-15. Darn good stuff, but needs to be lightly sanded before applying paint. Of course the silver lining of an abundance of undercoating is that there is not much rust. However, I will need to come back later to repair some damaged areas.

Next steps will be to epoxy prime and paint.



November 08, 2016

Further repairs on the heater ducts was necessary. After cleaning the dirt, grease and mud wasp nests off the front heater duct, it was found to be seriously cracked

I suspect these are stress fractures due to warping with age of the air entry opening.



After drilling out the rivets the repairs were made using epoxy impregnated Kerdi membrane as described above.

The repairs were made leaving the opening warped, which was necessary so that it will nest with the preceding duct, which is also warped (but not cracked).



FYI: The felt that Clarks provides for the rear duct is a perfect match for that on the flapper door of this duct, and I used it for that purpose. The original felt was glued and stapled; I used Clark's contact cement adhesive but did not replace the staples. The repaired duct, reassembled with Chicago screws:

November 20, 2016

First finish paint has been applied to right and left rear fender compartments – the left side battery compartment and right side space above muffler. I decided to complete these areas before repainting the surrounding parts of the undercarriage since some repairs were needed on the left side, and these compartments are easily masked off when painting the engine compartment. Some repair is needed to the front edge of battery compartment opening, but I can do that later also by masking the lower parts.



Both areas were partially coated with undercoating; these are annoyingly tight spaces to work in! After stripping it to metal, the battery compartment had more rust than expected (and when isn't this space rusty?), and patches were needed in several areas. Here's some of the metal removed, other areas needed to go as well.

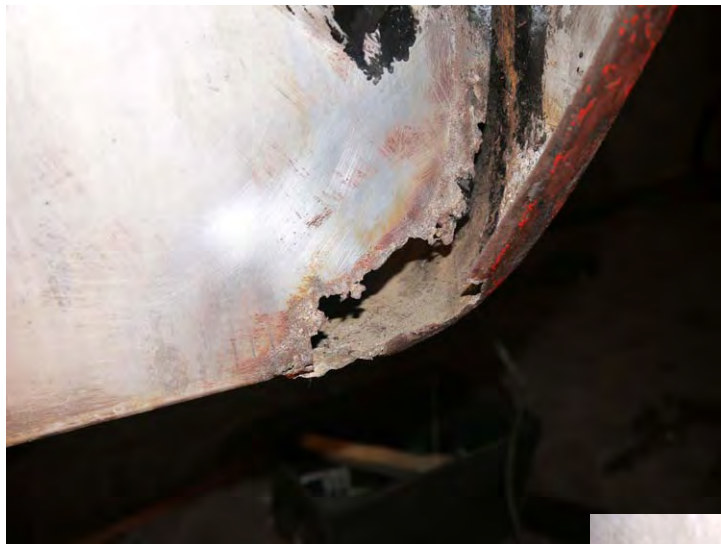

Rot found on the fender splash guard, and the lower edge of the wheel opening molding.

Patches were cut from 20 Ga steel, which are always edge (butt) welded. Cutting patches to fit correctly takes careful work,

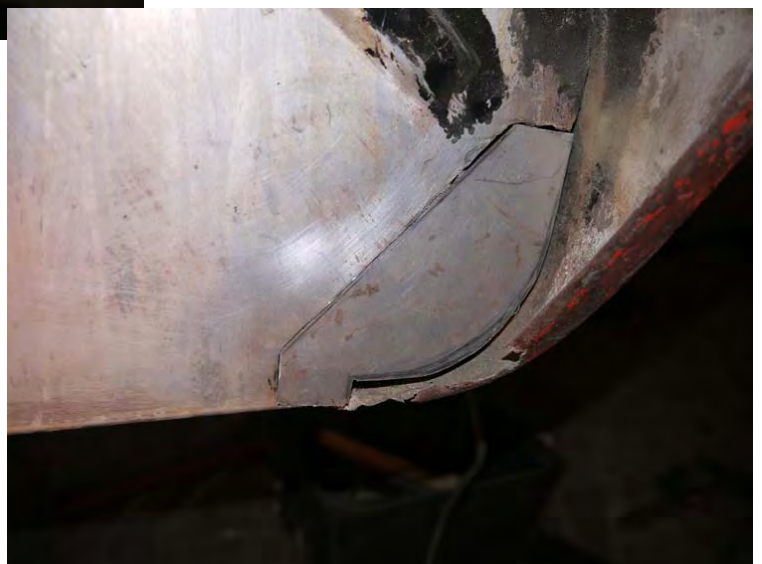

and fabricating curved areas, like the bottom of the wheel well opening, more so.

Most of the rust was on the inside lower surface. Some pitting, but most of the metal was solid, except where I placed the patches. I decided to treat with POR-15 rather than replace the whole panel.



And more challenging yet is welding these to old metal without blowing holes. But with lots of time all can be done.

Most of the rust was on the inside lower surface. Some pitting, but most of the metal was solid, except where I placed the patches. I decided to treat with POR-15 rather than replace the whole panel.



All loose rust was power wire brushed off, and the surface was scrubbed clean with POR-15 degreaser and then treated with Metal Prep, before applying two coats of POR-15.



POR-15 must be painted before it cures; if allowed to fully cure, POR-15 must be sanded before repainting. I prefer not to have to sand, so I waited until the POR-15 was tacky to the touch, but without leaving any paint on the finger (about 3 hours). At this point the second POR-15 coat was applied, and after waiting again, then the epoxy primer was applied.

And the compartments with the final paint, shot about an hour after applying the epoxy primer.

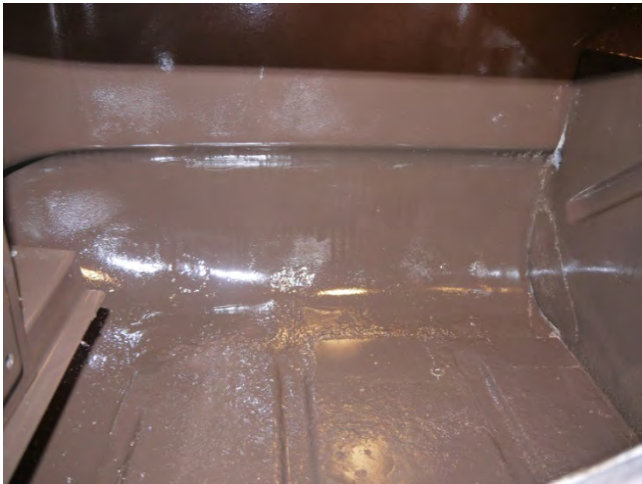

The undercarriage of the Firebrier was painted a dark chocolate matte brown, which I had matched as closely as possible at the local paint shop. The color was only available in PPG Concept formulation; this is really expensive paint but applies really easily. As best as I know, the original fender seal is no longer available. This is a close match (Soff Seal 9347), although the bulb is smaller than the original. The original seal was stapled in place; it would be really hard to repro that here, so I will use weatherstrip cement to secure it.



The battery tray needed some work. One of the sides had been pulled outward, undoubtedly to accommodate a bigger battery.



To facilitate straightening, I decided to remove one of the sides ... no, that's untrue... one of the sides loosened up and was easily removed, which made the repair easier. Here's the tray stripped and ready for finishing

Holes are drilled in the sidepiece to allow rewelding to the tray.



Here's the tray after priming and painting.



November 21, 2016

Back on August 21 I reported concerns about the bent undercarriage. The bends were found in the right and left side rear outrigger sills, that extend in front of the rear wheel wells. It's likely that the bends were the result of careless towing.

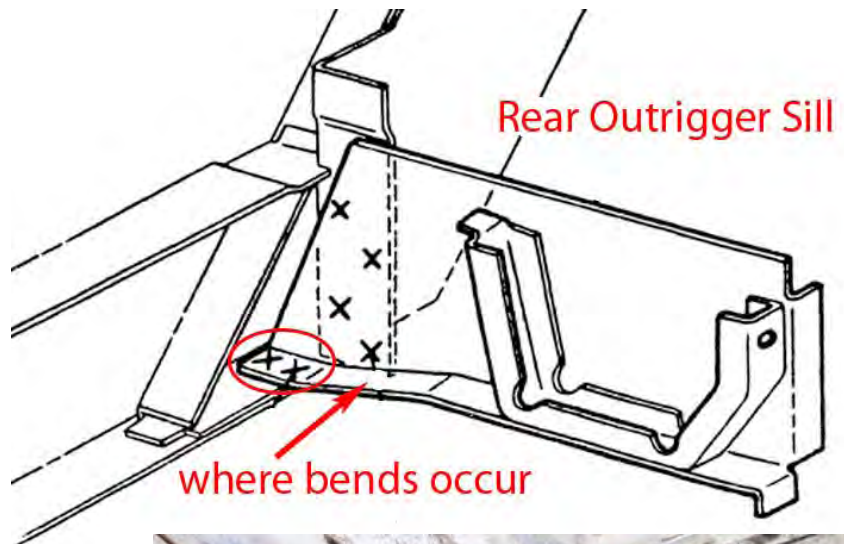

Here's the original condition of the left and right sides.

Consensus appeared to suggest that this wasn't a big problem, But I asked my body shop guy to visit and take a look. He also felt it was not serious and thought it could be fixed. And so, with torch, mallets, metal working hammers and dollies I went at it.

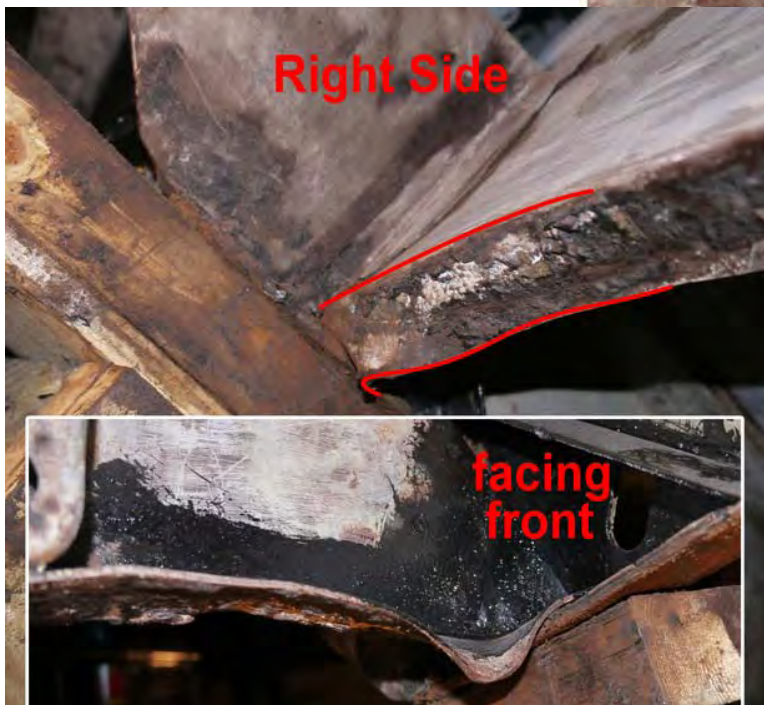
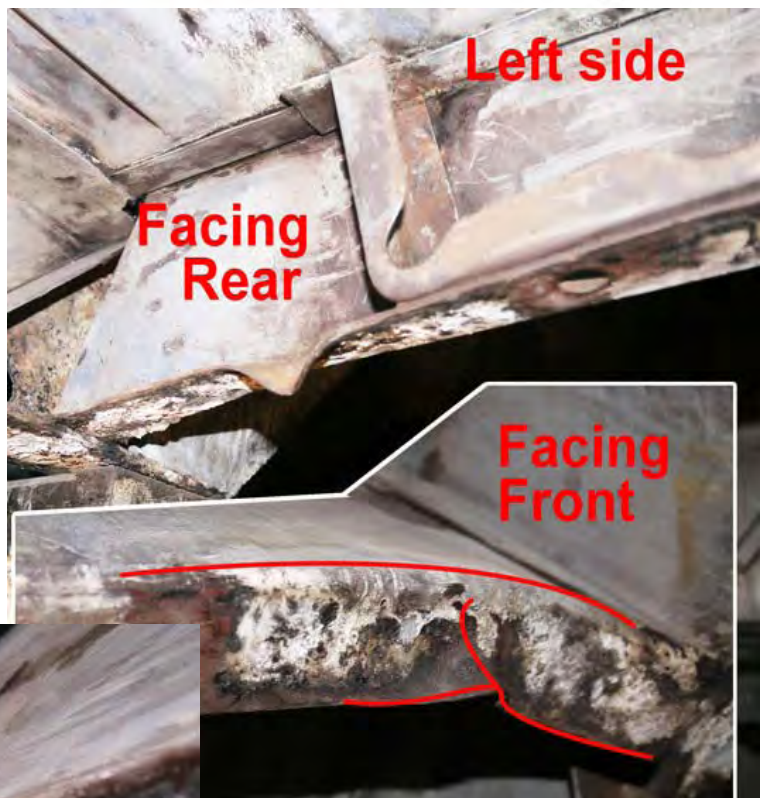

It took about an hour for each side, aligning the edges to a straight edge, and carefully working the 'dimples' flat again.



Here's the end results for the left side



And the right side



During the repair I noticed that the bottom of the outrigger sills had pulled away from the side rails, suggesting that the problem arose because the outrigger arms were not spot welded, or the spot welds failed, in the positions circled in the first diagram. I am going to add welds to secure the structure.



And here's another side project (and an inspiration for AI with his recent acquisition of a FC jack). I purchased this jack from John Sweet on ebay, It was in good condition but with a lot of surface rust.

I first degreased it and then treated it overnight in my electrolytic deruster. Finish work was done with a wire brush wheel, and blasting rust in nooks and crannies. I painted it SEM etching primer and then Blitz Black.

Here's the end result.



November 28, 2016

I've begun to receive some replacement body parts, so decided to go ahead and repair a rotted outrigger sill brace. Here's what it looked like before and after removing the undercoating. The bottom of the brace was pretty well rotted away.

The outrigger sills are the undercarriage supports that extend out to the side rocker panels. This diagram from the assembly manual shows the brace on the left side, although I was working on the mirror image brace on right side.

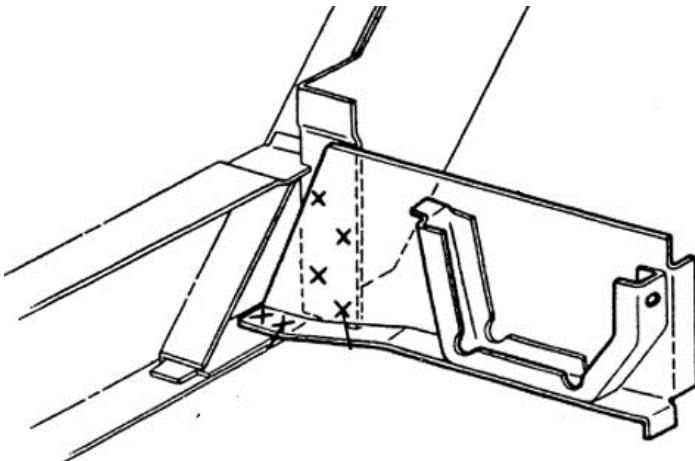

This is the same area that needed to be straightened as previously described. The condition of this brace is important since it

is the position where the van is supposed to be jacked when replacing a tire.

The rotted brace was removed by drilling pilot holes from the back side through the center of each spot weld, and then using a spot weld drill on the front side. There were plenty of spot welds, including four on the bottom.



It was helpful that I could cut the original brace into pieces as I worked to better access spot weld and rip it out. The outrigger sill itself shows some rust, but was pretty solid.

This is the replacement. Cut from a body piece provided by Jeff at the Corvair Ranch. It needed to be extracted more carefully, but the surrounding metal could be sacrificed in this case.



Here's the replacement brace welded into place.



and as viewed from the back side.



Those pilot holes shown above were expanded to 1/4 inch, and used to weld the brace from the back side. Additional spot welds were replaced from the bottom and front side, and all were ground smooth.

Just needs to be prepped and painted with POR-15 where needed.

December 04, 2016

The rear undercarriage and engine compartment have finish paint. It's taken a lot of detail work to clean all the nooks and crannies to satisfaction, making sure all the surfaces were adhesive. All areas that were encapsulated with POR-15 were sanded with 330 sandpaper. These are the paints I use (plus appropriate hardeners and reducers)

The Omni Acrylic Urethane was mixed to match the FC bed color.



The PPG Concept was the only paint that could be matched to the original undercoating color (with some custom tweaking) with a low matte finish. Darn expensive stuff, but coverage is quick and thorough, which is valuable when painting tight spaces, such as inside of rocker panels. After first applying the epoxy primer and allowing to cure an hour, everything receiving undercarriage color was then painted.

Here's a few views. First, with original undercoating



and now finished



inside wheel wells

The hinge areas are really tight

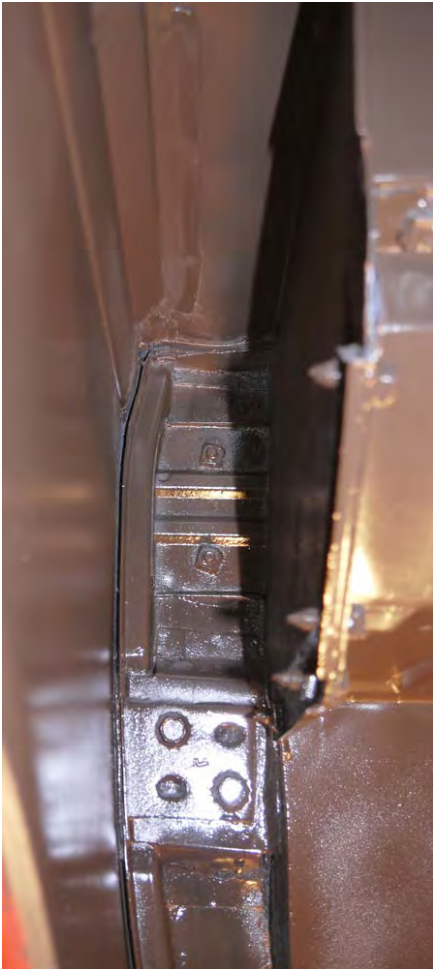

Here's the bottom of the battery compartment; repairs to this were described previously



The engine compartment was painted the next day (the epoxy primer can be top coated directly within a 3 day window). I suspect that the Chevy paint shop did go to any length to protect the undercarriage from overspray, but I masked off areas. Here is the engine compartment with epoxy primer and some of the masking.

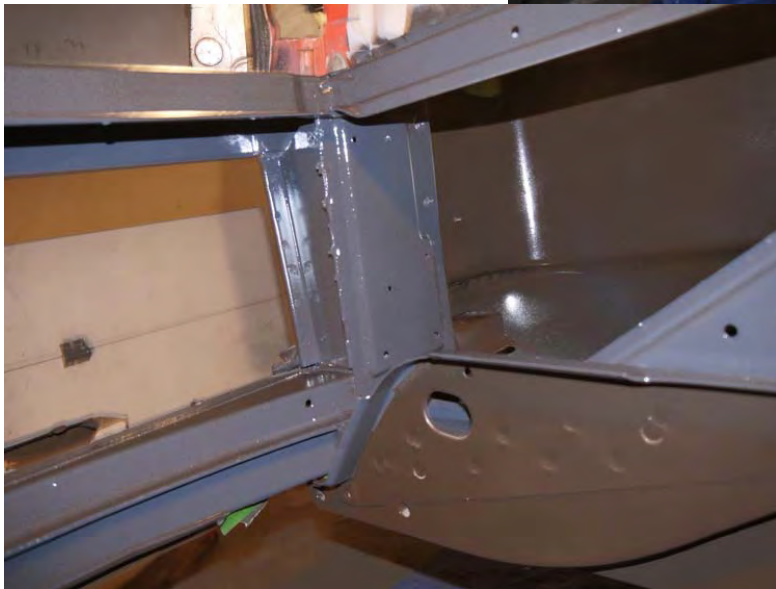

The finish paint



Speaking of lots of nooks and crannies, the rear engine mount bracket is grueling to clean but looks really nice when painted.

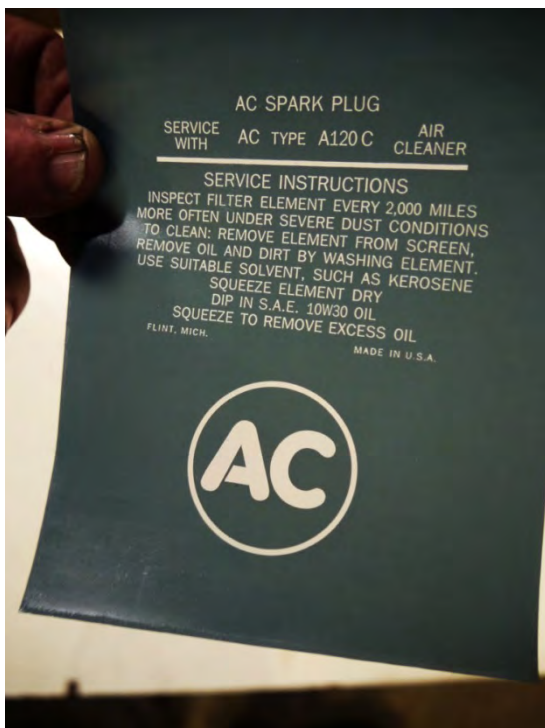

December 05, 2016

Here's a high resolution stencil I made of the air cleaner label.

December 15, 2016

Post your best guess at how much it weighs (I'll post actual weight in a few days). Granted, there's some dirt (and mud wasp nests) mixed in, which compensates for all the undercoating dissolved into solvents.



Paul is the winner with his guess of 42 lbs of undercoating, off by only 1 pound. Image of the scale, tared for the weight of the container, showing 43 lbs of undercoating.



I removed the front bumper and lower body corner pieces to gain access below the cowl. Those corner pieces were well undercoated.



They look good, no serious rust, but will need metal work to restore shape.

I used a different method to remove much of the undercoating on the front end of the Firebrier. Dry ice.

I had read online about using dry ice to remove undercoating, but didn't try it until now. I purchased 30 pounds of dry ice pellets, and spread piles on flat surfaces above areas with undercoating (the piles were also covered with blankets for insulation). When the metal reached deep freeze in about 10 minutes, extending about half way down the sills, the undercoating chipped off rather easily, often in large flakes using just a small putty knife.



I found the pellets held up for several hours, long enough to remove the undercoating from several locations, before subliming away. Not only was this far easier than using the torch and vibratory multitool, but the undercoating came off much cleaner, leaving the paint with almost no residual undercoating.



If I did it again...

I would buy 100 lbs of dry ice and use it to remove the undercoating on all of the upper surfaces of the undercarriage. The torch, vibratory tool and elbow grease would still be needed in other areas. And of course, a lot of detail work is required to remove residual undercoating and original paint before refinishing.



Here is the innards of the air cleaner oil bath; cleaned and flushed with gasoline to wash the jute packing.



The exhaust manifolds have been cleaned and painted.



The studs were pretty rusted and were upgraded with stainless steel replacements from Clarks. With some serious heat and torque, two studs were extracted intact, but two snapped off. These had to be drilled out up to 5/16 dia and then retapped.

I noticed that the exhaust system was not included among the applications listed for standard VHT High temp paint, so I used their extreme high temp "Flame Proof" paint. Both the primer and paint were heat cured as directed. Overkill? I rest comforted knowing that, should the engine ever catch on fire, at least the exhaust manifolds will still look good!

**December 21,
2016**

The shrouding is
Back (In Black!),
blasted and powder
coated (click on
image for larger
view)



And the air cleaner
canisters, etc., have
been blasted and
painted (click on
image for larger
view)

These were primed
and then painted with
a semi-gloss acrylic
enamel custom mixed
to match the original
color. This paint uses
a hardener, which
will make the paint
resistant to engine
conditions.



As you may have noticed, the engine sealing fabric has been installed on the shrouds.

Installing the fabric correctly was one of the most exasperating projects so far. The task is particularly arduous because the replacement staples need to go through the original holes of the shroud and retainer while passing through the tough fabric seal in between. Keeping everything aligned is not easy.



Furthermore, the staples that Clark's sells were too narrow, and each one had to be expanded. I used this little jig, into which each staple was hammered to spread the legs.

I don't think this was Clarks' fault, rather just variation in GM's assembly tools. The staples are also made from a slightly larger gauge wire than the originals, necessitating expanding all of the holes (I used a #51 drill bit).

The best way to install the fabric was to start with the staples in the center of the shroud and then work outward, doing approximately every other staple. I found this is the best way to assure that the staples holes would line up. It was, none-the-less, a challenge to get each staple through the holes on both sides.



The staples came with a few suggestions on how to crimp them. One suggestion is to use needle nose pliers, but I found the staple wire is too strong to bend by hand. I used a metal punch.

All four are done.

Actually, staples of the rear seal pass only through the shroud and fabric (no retainer). I also was intrigued that the staples of the front shroud were inserted in one direction on the left side of the shroud and in the other direction on the right side (so I replicated this).

January 06, 2017

Doing a lot of detail work removing the final traces of the Firebrier's undercoating, hoping to prime and paint within a week. As in the rear, a few undercarriage body repairs will still be needed. Some of those repairs are awaiting arrival of replacement body parts – weird west coast weather is not helping – but I've made some repairs that needed fabrication.



I should have expected that even though it was well undercoated, the bottom for the front cowl would be rotted since water can get in through the front grille. Here's images of the left and center sections of the under cowl (there was somewhat less rot on the right side)



Where to cut the panel can be a tough decision with several compromises. Ideally the replacement piece is as small as possible requiring the easiest fabrication, but obviously large enough to weld to decent metal, which can be hard to judge when you can't see the back side. However, when working in tight spaces like this, it's also necessary that the seam will be accessible to the welder (I use a MIG) and later by a grinder to smooth the weld. As you can see here for the left side, after I removed the panel and did some cleaning, the inside of the cowl was painted with POR-15, masking the edges where welding will occur.



I fabricated replacement panels using 20 ga steel. It takes a lot of metal work to replicate the original pieces. Here's the left side replacement before drilling the holes in the bottom lip; several holes were also drilled for plug welds. The back sides of replacement panels are treated with weld-through primer.



Fitting the replacement into place can be tricky, especially in tight spaces like this, and using several strong magnets helps. My method for getting a good fit is to initially make the replacement slightly larger than the hole, and then remove the excess old metal by cutting along the edge of the replacement with a Dremel tool (409 or 420 cut off blades work well), and spot welding the pieces as I go along. This assures a tight fit between the pieces, and the spot welds hold the piece in place. Hopefully, a continuous weld can be applied without blowing through any old metal, but that rarely occurs in my universe.



Here are the two panels with the welds ground down. I use a 4 1/2" angle grinder, where accessible, and a Dremel tool with fiber impregnated cut off wheels.



I use All Metal filler to smooth the surface of the welds and fill any pin holes. This stuff is rock hard and water proof. I went ahead and applied primer so that I can better assess the final appearance.

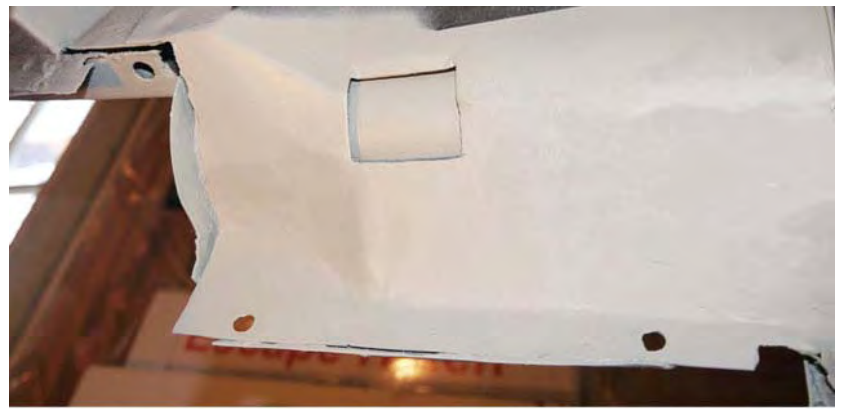

Another repair has been to the left side rear intermediate side door jamb, which was rotted on both sides. The picture of the back side shows the bracing below the hinge, most of which was beyond saving.



No hope for replacement body parts here - a left side door jamb - since there aren't many (any?) 8-door FCs being parted out these days; so fabrication is necessary.

As explained above, several factors were considered when choosing where to cut the old metal, and how to piece together the replacements, such as being able to reweld in suitable places. Here, there is another issue... being sure not to loosen/alter the position of the hinge mount, which could screw up positioning of the door.

The lower extension of the cut was made in order to remove some of the rotted metal behind it.

Here's two of the refabricated pieces. The large one will form the inside face of the jamb and a vertical brace in the rear. Note that body screw nuts are being replaced, and holes are provided where plug welds will replace spot welds. Overall, seven pieces were required, which included repairs to the exterior skin below the jamb.



Here, replacement parts are being installed. I had to plan carefully the order in which the pieces will be installed so that appropriate welds could be made, and ground down – I intend that the restoration will not be apparent on either side.

Here's the completed repair after applying epoxy primer.

January 12, 2017

It's done, essentially; the undercarriage, that is. Front half is now stripped, primed and repainted. A few pics:

Front wheel well after / before :



pedal bushing brackets after / before:



Center undercarriage after / before priming



It took a lot of work to clean all the crevices, such as around the gas filler opening

Essentially done, because there is still some body work to be done.

In summary, here's the steps I followed to remove the undercoating and refinish.

1. Remove bulk of UCing; heat and vibratory tool or dry ice and scraper.
2. Remove bulk of residual UCing and undercarriage paint: airplane stripper and lots of wire brushes. (I used about 3 gallons of stripper.)
3. Remove residual stripper and additional UCing: diesel fuel, scouring pads and lots of wire brushes. (I used about 3 gallons of diesel fuel.)
4. Degrease: POR 15 degreaser and various brushes and scouring pads. Spray off with water. (I used about 1/2 gallon of degreaser.)
5. Metal Prep: POR 5 Metal Prep. Spray off with water. (I used about 3/4 gallon metal prep.)
6. Remove remaining UCing from nooks and crevices: spray with isopropyl alcohol and more wire brushes. (I used about 1/2 gallon alcohol, and overall, about 75 small wire brushes)
7. Rust treat: POR 15, only on areas with surface rust.
8. Prime: Omni 170 epoxy primer after POR 15 is slightly tacky but not yet cured.
9. Paint!!!: PPG DCC Acrylic Enamel; before primer cures.
- [10. Go back and touch up finish paint]

I wore a full face respirator when using the stripper and when priming and painting; and replaced the filters 5 times - whenever I found fumes leaking through.

January 13, 2017

And here's a recent acquisition - the original siren from the Firebrier!!



It was generously gifted by someone from the Malden West Camp Fire Company. This is a Federal Siren 66G siren - a monster of siren - and can be seen in the original painting of the Firebrier (back on thread page 1). Overall, it's in excellent condition. I'm looking into having it restored.

January 23, 2017

The powertrain has a new lease on life! What arrived looking like this with extensive internal damage has been resurrected from near oblivion by Ken Hand.

You may recall that essentially none of the internal moving parts of the engine nor the cylinders were salvageable. Three of the pistons had holes in them. But fortunately all of the major components that were coded and dated could be saved. This was important since the FireBrier was outfitted with a rare FC 102 HP engine and positraction differential that I wanted to save. Here are a few pictures Ken provided.

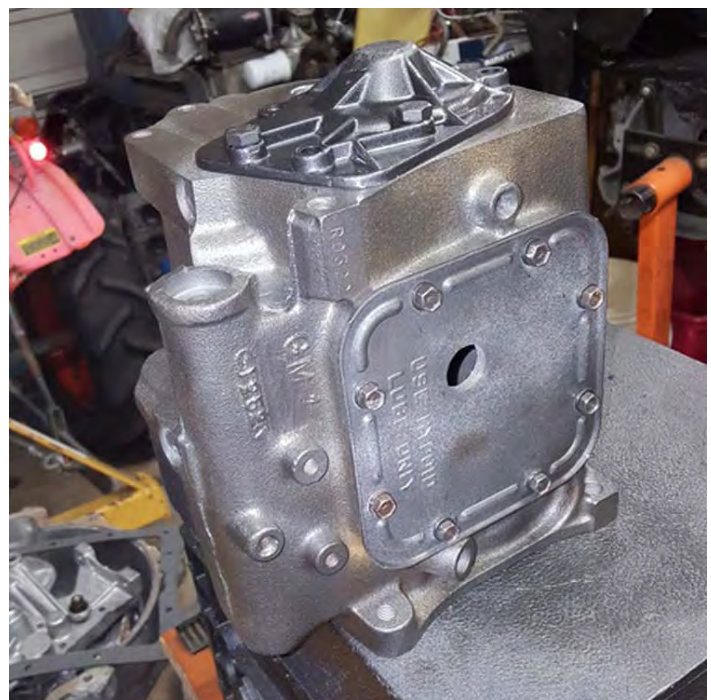
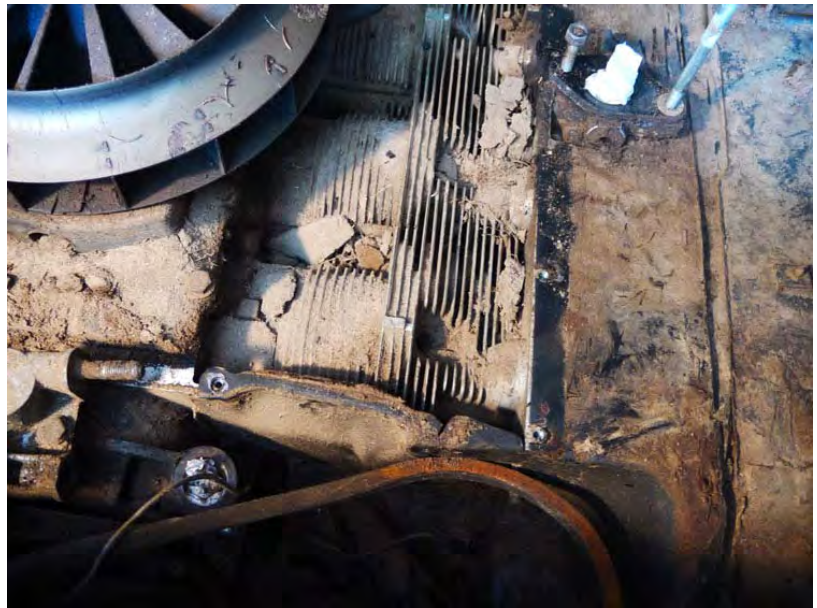

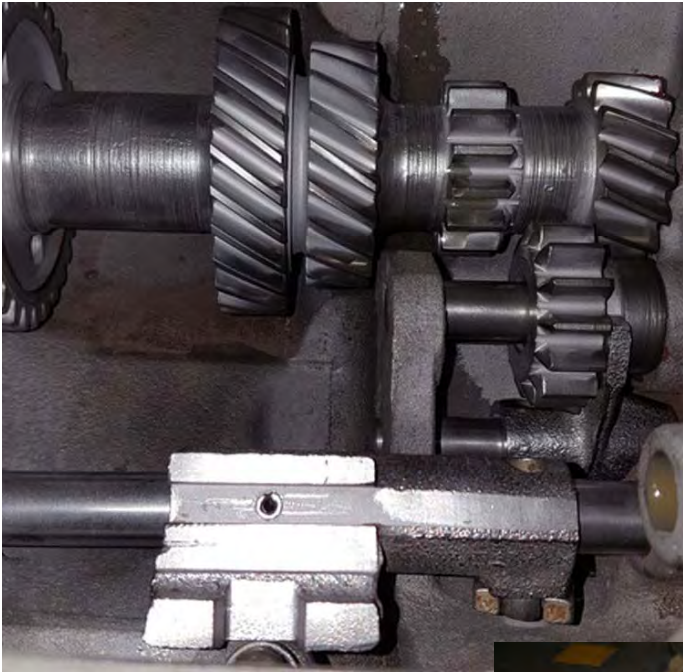

In the positraction differential a damaged postraction clutch housing needed to be replaced - provided by Jeff at the Corvar Ranch. Apparently this was a common problem.

So the powertrain is looking much better and has been rebuilt to last another 50 years, at least.



Reassembling the rear crossmember and suspension is near the top of the to-do list (I've been procrastinating hoping some vintage rear shock absorbers appear), along with beginning to reinstall the cables in the undercarriage. But alas there is still some body work to be done down there, which is being delayed by the nasty weather out west -- I thought the Mamas and the Papas declared that it never rains in southern CA?



February 09, 2017

As I await arrival from CA of replacement parts for the undercarriage, I've decided to start stripping the interior.

The interior rear panels were removed and the interior paint of the engine bay has been stripped. The metal was thoroughly washed free of stripper, cleaned with POR 15 degreaser using scouring pads and then metal prepped. I always metal prep not only to enhance binding of the epoxy primer, but also to prevent flash rusting until I do the priming.



Another task involved patching some holes. I probably should have done this before refinishing the underside, but I won't claim to always do everything in the most logical order. I remember a recent thread (I forget who posted) about the daunting task of doing an entire restoration, and looking ahead at all the work that is still needed. My solution is to often do something that I feel like doing at that particular time, even if it's not the most logical next step.

At any rate, there were about a dozen holes drilled through the metal over the powertrain and rear wheel wells, probably where fire equipment was once secured. I had considered leaving these holes, but then decided to fill them. I'll redrill as necessary when/if I can reacquire original fire equipment. The holes ranged in size from quarter to three-quarter inch diameter, and were resealed filler metal disks:

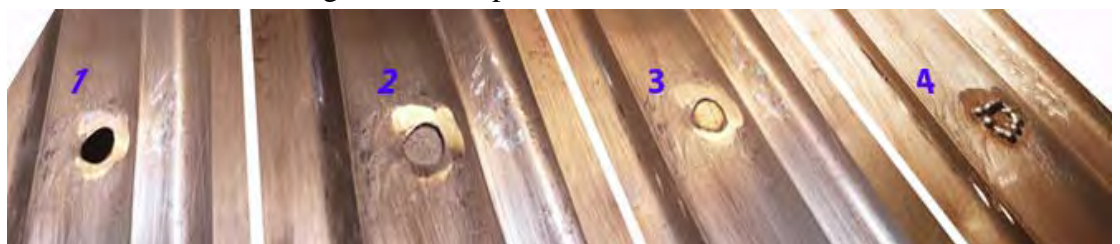

The metal around the holes was often quite distorted and needed to be work flat again (#1). A magnet covered with a thin sheet of aluminum was placed below the hole (#2) to hold the filler disk in place (#3), so that it could be welded in (#4). After grinding off the excess weld, some filler was used to smooth the surface. I also resanded the underside which will be repainted.

But along the way, a number of repairs were needed before priming. One of these was to the battery compartment opening. Some fool had cut and yanked out the front edge of the opening, undoubtedly to fit a larger battery (#1).



Plan A was to cut out the bent section and weld in a replacement. But when my local body shop guy stopped by to look at the FC he will eventually be painting, he said that it would be better to metal work the bent region back into place. Sounded like a good idea to me, and after about 4 hours work it was back in place (#2) but still so warped and uneven that I decided it never could be made right.

Apparently metal working this piece was beyond my skills, but it didn't help that this is about 18 gauge steel and

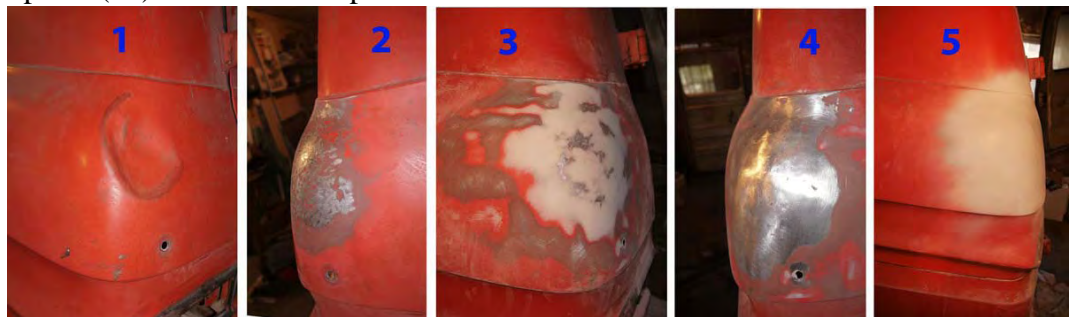

it often was not possible to position a dolly where needed while hammering. OK, so back to plan "A", and the front edge was cut out and a replacement (from the Corvair Ranch) was welded in (#3), after grinding down the weld, the surface was smoothed and contoured with filler (#4).

That rear corner also was the location of a significant dent. Metal working this back into shape was more successful. Working with a variety of hammers and dollies, from the inside and the outside, the metal was carefully roughed back (#2). To begin the fine shaping work, I apply a skim coat of filler and sanded it down to find the high and low areas (#3). The metal is then repeatedly reworked while resanding the filler until the surface has been largely smoothed (#4), and my goal is to do the finish work with high build primer. I have applied a temporary primer to prevent rust until the exterior is refinished (#5), and I won't really know until then if I will need to use any filler to get the final contours right. Although I didn't get a picture, the inside was also made right, with a little filler, so that the metal work will not be apparent. I'm sure a pro could do this faster, but this little project took me about 5 hours!

February 11, 2017 The extended length of FC rear shocks is 13½” , and 14¼“ seems appropriate for the fronts, unfortunately original FC spirals seem to be essentially pure unobtainium so I’ll have to make some substitutions. I have acquired NOS spiral shocks with appropriate dimensions for the Firebrier, and my intent is to match the extended length as best possible, recognizing that the valving may not be optimum.



I have NOS EM car spirals, and the fronts (3178178) have an extended length of 12 7/8” which is pretty close to the FC rear shock, so I’ll use these there, but with an extended length of only 12½” I suspect that the car rear shocks (3178179) are too short for the FC. I recently obtained two NOS 3197656 spirals which have an extended length of 14¼”, and I plan to use those in the front. The problem is that the bottom bracket has hole spacing of only 2½” and the FC requires 2¾ “.



So I pressed out the original bottom brackets and replaced them with brackets from corvair shocks. This is not simple because when the brackets are pressed out, the rubber grommets come with them and are irreparably damaged. I needed to recast new grommets, which I did using 70 shore urethane rubber. This required setting up a jig so that I could cast the rubber around the brackets within the casing of the shocks.



Rubber seals were placed around one end of the bracket to prevent the rubber from leaking while it set up. I used a two-part 70 shore urethane rubber and additional rubber seals where added to the other end; these seals also molded the extended ends of the new grommets, as you can see in the shocks with the replacement bracket and grommet

I'll be repainting the shocks to match the original GM shock gray, and the new grommets should be almost indistinguishable.

A couple of other rubber repair jobs...

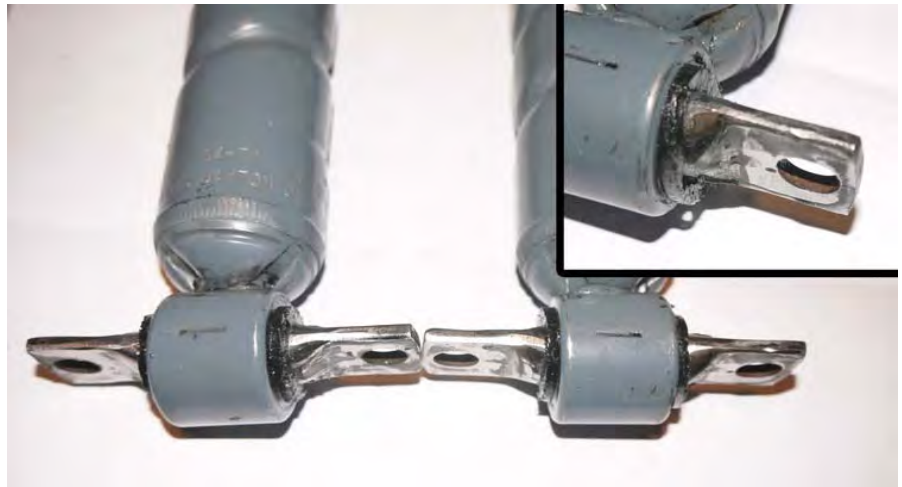

The original style electrical harness retainers are not available – the originals have an unusual clip on the back that holds them in place. The rubber is often damaged or discolored, and it's difficult to remove them without breaking that little clip. I've been saving good ones for a while to restore. On the undercarriage there are also some retainers that are spot welded, and the rubber on these is also often no good after 50 years.

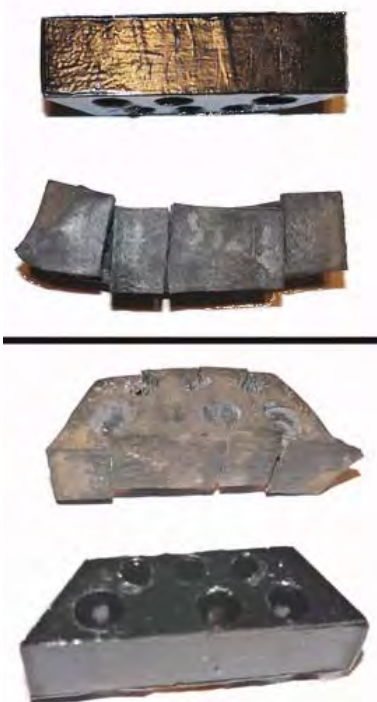

I removed all the rubber before repainting the undercarriage. And finally, the engine top shroud has two retainers for the spark plug wires, and the rubber on these needed to be removed before powder coating. The rubber on all of these retainers was restored using the same urethane rubber.

I had posted a thread recently looking for the FC cab floor cable/harness grommet which has the part number as 3787262. Clarks does not offer a repro, and I didn't hear back from anyone who had a NOS one. So I decided to repop it myself.

**March 07,
2017**

Finally more progress, and the last of the body rot to the undercarriage has been repaired.



The following pictures show an assortment of stages in the repair process. Some of the replacement parts were extracted from a good quality CA parts van by Mike Deklotz of Mike's Auto Parts, although some pieces needed to be fabricated.

The front right (passenger) side rocker panel and floor pan were in sad shape.

Like lots of rust-belt FCs, the dog-leg "ankle" was pretty well rotted, with serious rust extending down along the face of the rocker panel; and a good size chunk of the floor pan was also beyond salvage.



Above we see the rotted part of the "ankle" cut away (you can see the replacement floor pan set in place behind). That segment was replaced before the floor pan was replaced, and the right side picture shows the floor cut away. You'll also notice that even part of the sill needed to be replaced as well as section of the weatherstrip support frame.

Here's a view of the dog-leg "ankle" partially welded in place. And there's my, mother-of-all, big-ass C-clamp that has solved a variety of clamping needs. To the right is the restored floor panel, primed with an epoxy base and 2K surfacer. Epoxy primer should be top coated within 72 hour, but if I'm not going to apply the finish coat soon, I always cover the epoxy with surfacer to assure proper bonding later on.

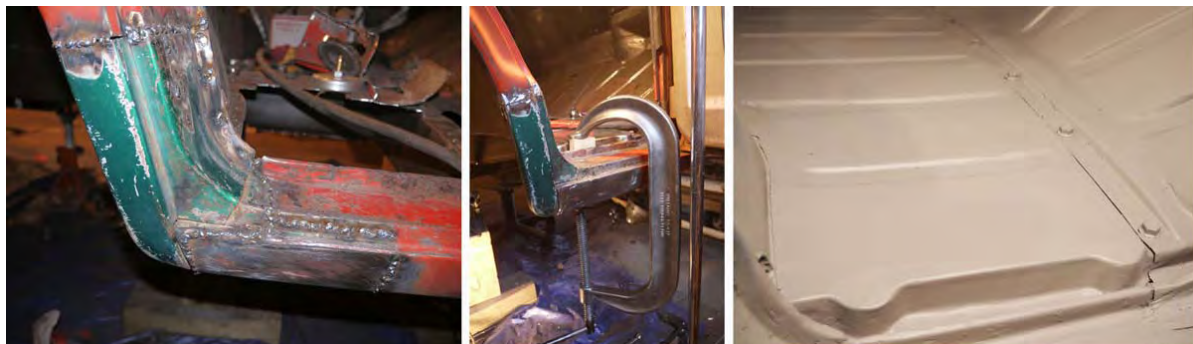

Much the same situation on the other side of the cab, although the floor pan was in much better shape. The right side picture shows the inside of the rocker panel painted with POR 15.

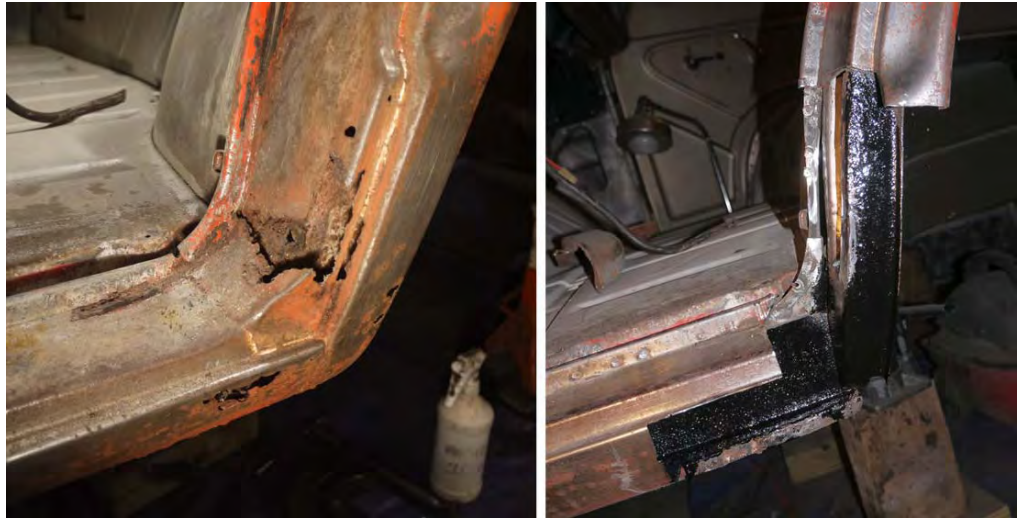

And here's the replacement piece spot welded in place, and then the weld lines after grinding and skimmed coated with filler.



Meanwhile on the other side of the wheel well, the jacking brace and associated sill were a disaster, but now are now fully restored. Indeed, the undercarriage has now been fully stripped and repainted, and soon I will begin replacing the undercarriage control cables. But first I'll be priming the Firebrier interior.



March 12, 2017

Some pictures of the near unobtainium . . . the Firebrier's newly restored 35 Amp LCI generator (Delco 1105135). Thanks to Ken Hand for acquiring the generator and doing a super restoration, and to Crawford Rose for providing helpful information about this type of generator.

Here's the generator before restoration and after being disassembled. There was some initial confusion because the tag appeared to be black, and Delco 12 Volt generators always had red tags. Turns out the tag had been painted along with the entire generator at some point. And here it is restored.



Notice that this generator does not have a smaller commutator end like the stock generator. Instead it has a removable metal band that allows easy access to (and replacement of) the brushes.



The 35 Amp LCI generator was RPO K71 and intended for FCs that had a high current demand, such as ambulance and fire department conversion vehicles. Undoubtedly it was installed in the Firebrier to power the original Federal Signal 66G siren, which could easily otherwise drain the battery, particularly at low RPM, and possibly other equipment.

LCI stands for "Low Cut-In". Generator cut-in is often defined as the speed at which the generator produces a voltage equal to that of the fully charged battery. The specifications show that the 5135 unit could produce 14 Volts (and 35 Amp) at 1730 RPM, versus 2230 RPM (and 30 Amp) for the stock generator. In order to produce higher current at lower RPM, a larger generator with more armature windings is needed, and this is well reflected in the substantial weight of the 5135.

March 15, 2017

After an initial false start, I have located an excellent match for the Fawn Poly interior color. As I had first posted in a separate thread, the Fawn Poly prepared at my local auto paint shop according to the original PPG 22151 color code did not match the interior color of the Firebrier.

So following Plan B, I brought in one of the rear interior panels to be color scanned. As explained to me, when auto paint is scanned the computer doesn't disassemble and identify the relative proportions of the individual color components (such as when latex paint is scanned at your local home improvement center), but instead looks for the best match from existing paint formulas. How good is the match must then be determined by mixing the paint and testing.

The computer matched GM 1963 Fawn Poly with Ford "Pueblo Gold, Light French Silk" (OEM CODE: G3,M7113A, 4LLEWHA,4LLEXWA), an exterior color for a variety of Ford vehicles in the last dozen years, or so.

Well, here's the paint applied to one of the rear doors - the new paint is on the right (in case you couldn't tell). I find it to be a superb match, almost indistinguishable (mixed as Acrylic Enamel) from the original. Somewhat more glossy, but I didn't really try to polish up the original lacquer. So this is a winner. Fawn Poly 22151 was used for 62 - 65 FCs, although I don't know how consistent were the GM colors from year to year. I painted some test cards, and if anyone is needing to paint an FC interior, I'll be happy to send you a card to see how well this will match.



March 19, 2017

Just to be able to say that reassembly has begun... I reinstalled some clips/retainers!!

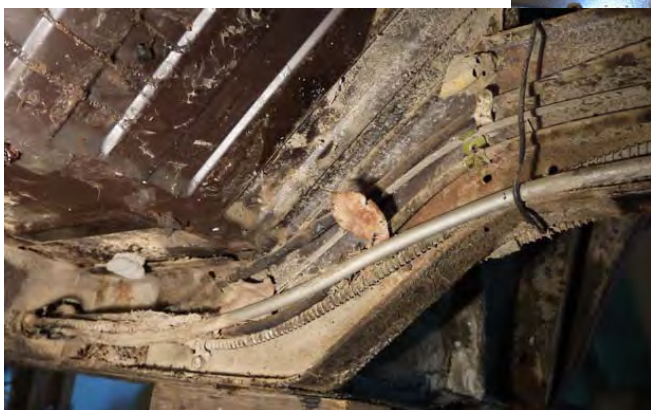

I'm glad I had thoroughly photographed the undercarriage because it was immediately clear where the clips were located originally, and indeed, the photographs show that there are more holes than clips.

I guess some of the extraneous holes were for other configurations. The assembly manual is helpful also. It does not always show exactly into which holes the clips were placed, but has some details that were not apparent from my original photographs, such as that on the opposite side, the heater cables are held in a loop-type fastener in the forward position.

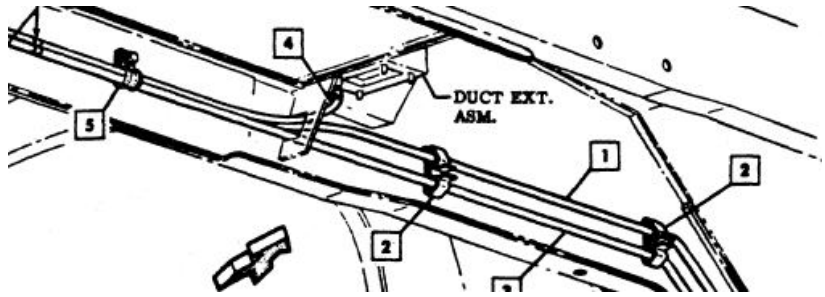

Which brings up an important point (for me at least) - on the repop clips that are available, the part that inserts into the hole is designed differently than the originals, and that some of the original double retainers had either two equal sized clips (for two heater cables) or two different size clips, and the smaller size clip was for a brake line.

March 31, 2017

Finally finished the load floor of the Firebrier; straight forward but a lot of elbow grease. As it arrived there was some serious rust and pitting, apparent after the paint was stripped, particularly on the left side.



One small area needed to be replaced, but everything else was restorable. Filler could be used to cover the rust pits, but I decided high build primer would be better.

The surface was first thoroughly wire wheel brushed to remove as much rust as possible, and then prepped for POR-15. Here it is after the phosphoric acid treatment. All the floor bolts were removed and the holes plugged.



The rusted areas were then painted with

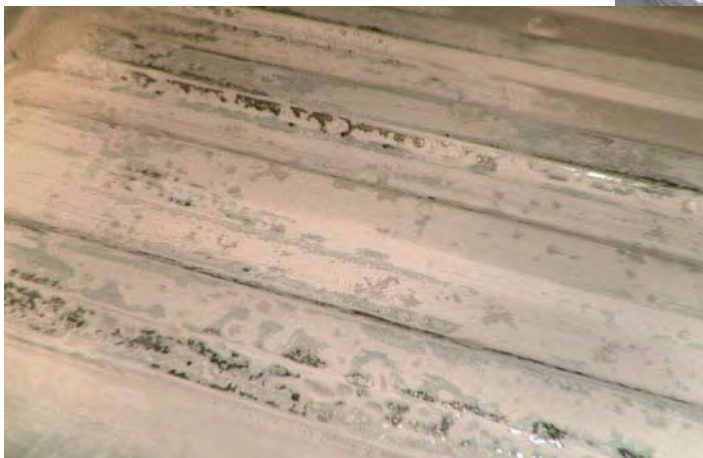

POR-15. When the POR-15 was not yet fully cured, the floor was primed with epoxy and then 2k high build primer. After the primer cured, the surface was sanded. Here's the surface after the first sanding.

3-4 rounds of the high build primer and sanding were required to hide the rust pitting and yield a smooth surface. Here's with the final coat of primer.

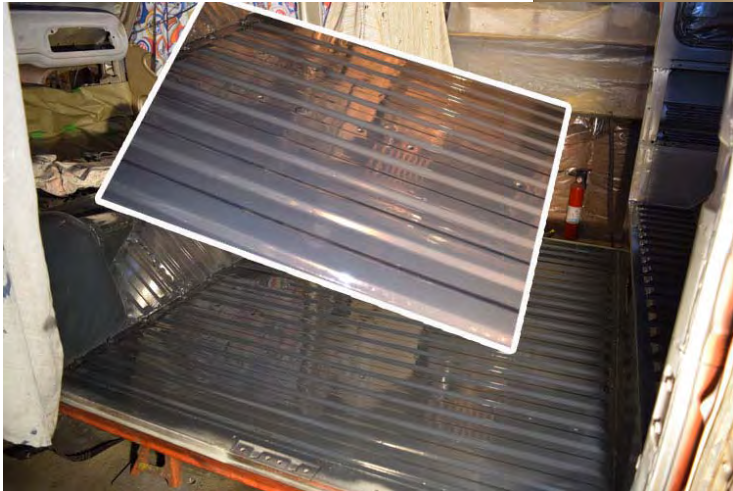

The finish paint is several coats of acrylic enamel matching the stock color.

April 12, 2017

After seeking help in some other threads, the steering box is ready to go. I suppose this was the last mechanical unit to be disassembled, but I was cautiously optimistic, since the Firebrier only has 15K miles on the odometer and the steering wheel seemed to turn smoothly. So, first, off with the pitman arm.



and then removal of the side cover to look inside.



Well, not too bad. Much of the lube had coagulated into semi-solid chunks, but the gears, etc., were still oily. Here's everything cleaned up. Hint: avoid dropping balls on floor and wasting time searching for them.

I did not see any pitting or serious wear to the worm shaft, sector gear, balls, races, or bushings, so all were reused. After doing some research in previous threads and other sources, I opted to lube with "00" gear box grease. Reassembly was done following the instructions in the article Taming the Wild Steering Box Rebuild. Here's my setup to make adjustments:



I acquired a 0 - 3.5 Newton meter (0 - 30 inch lb) torque wrench, and made an adapter so that it could be affixed to the steering shaft above the steering wheel. Having the steering wheel attached allowed easy large scale rotation, and pulling on the wrench allowed measurement of the drag. First, the worm gear adjuster nut was tightened, setting the preload on the worm shaft bearings to ~ 0.8 NM (7 inch lb), then the adjuster screw was tightened until the high point lash was 1.5 NM (13 inch lb). Concerning finishing, the box and cover were primed and painted with Eastwood Spray Gray (cast iron), although the worm gear adjusting nut was originally a brighter steel color and so painted with Eastwood Detail Gray. Although I have seen the steering column jacket repainted black in many FCs, the original color matched the floor, so that was used here.

April 12, 2017

Will soon be installing heater duct work, which is easier to do before installing the front and rear crossmembers and suspension. I had previously reported on restoration of the blower box and heater distributor boxes, I have since cleaned up the rest of the duct work.



Here's the "big picture. Almost the entire heater system is laid out. One reason I did this was to make sure I had all the gaskets and seals needed (which I numbered). I obtained a few NOS replacements, saved a few good originals, and cut a couple myself from 3/16" foam rubber; I'm lacking only one (#6 in the image is torn).



Like most everything attached to the undercarriage, the heater ducts were coated on the bottom with undercoating.

This could not be aggressively removed with heat (or dry ice) that might damage the thin plastic walls of the ducts. So I rigged up ways to soak each duct in diesel fuel to dissolve or soften the "tar", which could then be brushed or scraped off. The result was excellent, and the ducts were found to be fully intact and undamaged.



The metal fittings attached to the ducts were all stripped, derusted as needed and then primed and painted.

Likewise, so were all of the nuts, bolts, etc.



April 22, 2017

Progress and assorted side projects. I like to have several "irons in the fire", working on whatever suits my mood at any particular time. And it certainly has been a good time for some Spring cleaning; no, really, cleaning springs

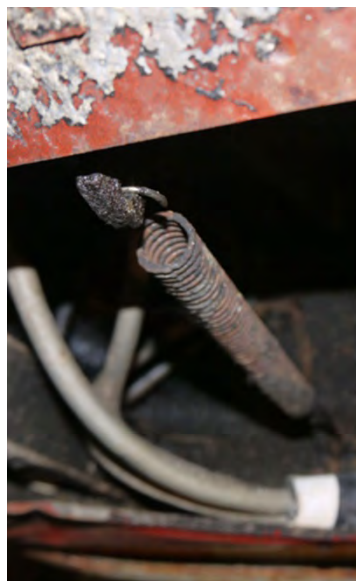

Even though many of the control cable springs looked horrible, they were all found to be solid once cleaned up. Saving the stock springs is really desirable since the replacements available do not always match the GM originals. I made the jig shown in the image to spread the springs, and they were derusted with a wire-wheel, soaked for several hours in phosphoric acid metal prep and wire wheeled again to remove internal rust, and then primed and painted.



Here's the gas tank before and after restoration:

No, that's a lie. It's a new tank and sender from Clarks.



And the tank, control cables, brake lines, front suspension, heater ducting, etc., have been reinstalled. Steering is still underway.

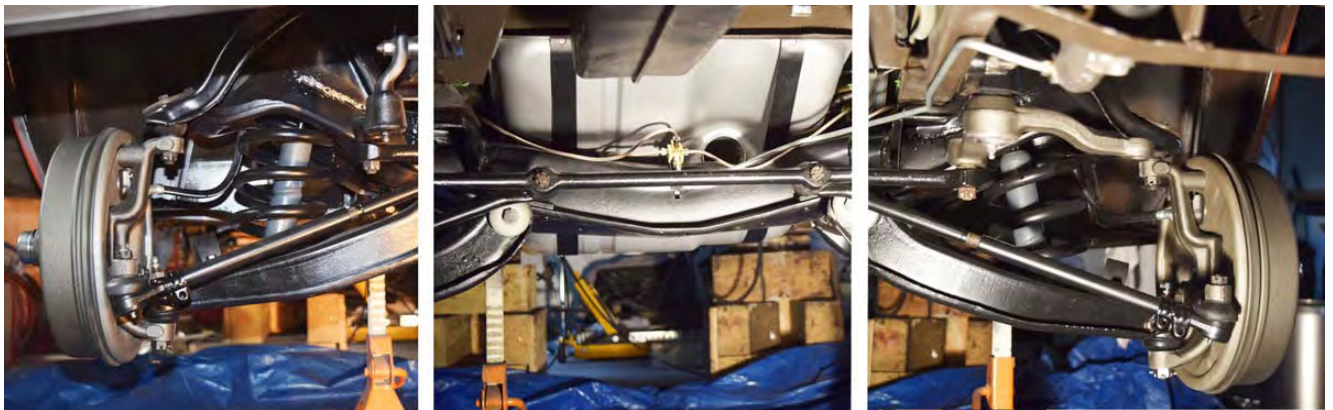

Spent a lot of time looking at photos of the undercarriage as it arrived and the assembly manual to assure all cables and clips were in correct positions. In a few cases, where the vehicle differed from the assembly manual, I restored to how the vehicle was assembled.

An interesting case like this was the engine compartment lids. Here's the top and bottoms after restoration. Both are painted the floor Charcoal gray on top and undercarriage brown below. As described in the assembly manual, undercoating was used as an adhesive to bind the fiberglass heat insulation. The assembly manual does not show insulation on the transmission/differential lid, but it was there in the Firebrier (and one more place where undercoating needed to be removed), so I reinstalled it there as well. The inset shows the replacement insulation (DMT Universal Under Hood Insulation), which is an excellent repro of the original: 1/2" of loose black/gray fiberglass with smooth black, tighter woven, layer on one side. This may be the same as what Clarks carries, but I'm not sure.

And finally, side door scuff plates.



May 15, 2017

Been a while since last post, and lots of progress has been made. On and off I've been working on the lower front corner body pieces, which were in pretty rough shape.



Originally, they looked horrible, surfaces entirely rusted. But after electrolytically derusting and wire-wheel cleaning, they turned out to be in excellent shape. The very end of one needed some of the metal replaced and some pitting needed to covered with All-metal filler, but the end result looks great; primed and painted with Rustoluem Matte Nickel.



Serious impact damage on both sides and enough rust in a few places to warrant new metal. Doing metal work on pieces like this is a pain - it's hard to hold the parts and also position a dolly and hammer; and there are a lot curves! I find the easiest way to do the rough metal work is in a sand box...

... simply a wide container (tupperware) filled with sand with a cloth cover. The metal reshapes by hammering the damaged areas into the sand, which acts like a big dolly.



Obviously it still takes judicious use of the hammer. After roughing the parts, a lot of additional metal work is needed to prep for priming.

Here they are stripped to bare metal and ready for epoxy priming, which has been done. Multiple coats of high build primer and sanding will be used restore the final contours.



The wheels have been refinished. Original 1963 rims, a couple in excellent condition, although most were electronically derusted and then blasted; but I still was not satisfied that all rust was removed, so four of the wheels were painted first with POR-15...

... and then epoxy primed. Interiors of the rims were painted gloss black, and the exterior is white - as shown in the vintage photos of the Firebrier. I would love to find some NOS 1963 14" wheel covers. (Got any?)

A "dry assembly" of the engine was done - putting on all the shrouds and ancillary parts to make sure everything is accounted for; and almost everything was. Here we see the engine with the powder-coated shrouding and repainted air canister and oil bath assemblies.



The beautifully rebuilt LCI generator is mounted (This also requires a hard-to-find regulator, which was secured). That's the original pre-oil bath hose, which has not been repopped and which I hope to clean better. I restored the original tower-style hose clamps, which will be used on all hoses in the Firebrier.

The engine will be "fired-up" after installation, so I refinished most of the Firebrier interior.

The interior panels have been painted separately. There was a learning curve in applying that metallic fawn-poly with acceptable results.

Much thanks to my brother John who visited last week and helped install the powertrain.



All went well. The engine compartment is painted the original charcoal gray, whereas the forward compartment is the undercarriage paint. The air intake assembly is removed to allow adjustments during the initial start-up.

You can click [here](#) to see a video of the initial start-up. Carbs were primed with some aerosoled gasoline a few times before it fired up, and the video shows start-up and later shut-down after running about 30 minutes. I had to tightened a small gas leak and adjust the timing several times before locking the distributor in place. Thanks again to Ken Hand for the excellent powertrain rebuild and Steve Goodman for rebuild of stock carbs.



Oh, the Firebrier is back on the ground - on 4 Cooper wide white walls matching the originals.

May 22, 2017

The passenger side door pillar had the usual rot around the upper hinge opening. Here's a series of pictures showing the repair:



1- original condition - serious rust up almost to the hinge opening. Equally bad on other side as well.



2- I did the cut-off along the top of the hinge opening - a reasonably reliable landmark for cutting the replacement. I was much relieved to find that rot was only "skin deep", and the subtending metal layer had only surface rust. When I did a similar repair on my 61 GB, everything was rotted, necessitating a much more complicated repair.

3- after cleaning off as much rust as possible, the underlying metal was prepped and painted with POR-15.

4 & 5 - and the replacement piece was welded in, welds cleaned up and then given a temp coat of primer.



The replacement piece was cut from a body section I got from the Corvair Ranch.

1- The pillar skin & support metal were roughly cut first.

2- Normally, the skin would be removed with a spot-weld cutter; but I didn't want to cause that much damage to this relatively small piece. So instead I carefully ground away the spot-welds from the back side, a time consuming process to avoid grinding into the skin layer.



3- Here's the replacement freed up from the sub-metal. Definitely not from a west-coast vehicle. After stripping the paint, it became apparent that rust in a



few places would necessitate metal replacement. Eventually several small holes were drilled along the sides for plug welding to the door pillar, and the inside was treated with POR-15.

June 04, 2017



Decided to strip and prime rear of the Firebrier. Plan is to refinish exterior in three stages, rear middle and then front. Would be nice to strip whole thing, but with humidity in the mid-Ohio valley, flash rusting would occur. I use aircraft stripper - here's after first application.

but it takes two applications with lots of wire brush work. btw: the area around any openings had been stripped previously when I had worked on the interior, this way I could tape over the openings to avoid getting any stripper on the interior paint



Then I clean it with POR-15 degreaser which neutralizes and causes the stripper to clump up, which I find helps to remove it. But getting all traces of the original primer is tough, so then I hit it with the sanders...

... first a rotary sander with 80 grit and then a random orbital sander with 120 grit.

Then I do any body work. I found a couple of small places where metal needed to be replaced and any small dings were filled. At

center rear of roof several holes needed to be plug welded, which unavoidably causes a slight deformation of the metal, and this was corrected with filler.

Finally, I wipe down the entire surfaces with POR-15 degreaser, and then with isopropyl alcohol. First OMNI epoxy primer was applied then their high build primer. Not much head room above the roof, so priming is a tricky undertaking. A fair amount of work is still needed. The damaged corner needs to be block sanded back to perfection. And there's nothing like primer to reveal all the other little dings that still need to be filled. Notice that I prefer to keep the rear windows in place, but I cut away the weather stripping so that all the metal can be fully prepped.



The rear doors were also done. The downside of restoring an 8-door is ... all of those doors, which have an awful lot of surface area. The inside of these rear doors had a lot of dings and bends, which I suspect was from fire equipment banging against them. Indents are very difficult to correct with metal work because there's no way to work from the inside of the door. Most of the dings are small enough to fill, but several needed to be pulled with a stud welder, such as the 1/4" indent to this contour feature.

The Harbor Freight stud welder I purchased when I did my 61 GB came in handy. It takes a fair number of studs to pull the metal without creating a dimple. Rather than using a traditional stud puller, I feel I have better control pulling on the studs with a leverage bar.



I use whatever rigid bar is handy with a suitable length. Moving stud to stud, the metal was pulled out until the original contour was achieved. You definitely do not want to pull so hard as to pull out the stud (and maybe leave a hole), so using several studs is best. Unfortunately, all the studs then need to be cut off and carefully ground smooth. The pic shows the 4 studs in different stages of removal. The doors

were prepped and other damaged areas corrected as for the van body. Epoxy needs to be top coated within 72 hours, so I almost always finish with high build primer.



June 11, 2017

I have been slowly acquiring and restoring (or having restored) fire truck equipment. On the roof were the siren, beacon and spotlight.

Here's the beacon light, a Federal Sign and Signal Model 17, fully restored and an exact replacement for the original.

I learned that the skirt (base) of these is often cut to fit particular applications, so finding one with an unmodified full skirt was fortunate. The white (rather than black) gasket is appropriate.



Although the Unity spotlight was not in bad shape I located a NOS replacement:



The siren was missing the mounting base and needed repair, including welding of a crack in the cone, before being rechromed. The work was done by Gary Cahill of "Rescue Market", in Elyria, OH.

A few weeks ago, I took a trip to the Malden West Camp Fire Company, in Saugerties NY, the home of the Firebrier. There are two fire houses (Malden and West Camp), and here's the West Camp station:



I was generously given several original items including a vintage fireman's hat,

respirator; - the respirator is missing the air cylinders and will need some restoration, a future project - and portable two way radio. This also will need some work, lacking the antenna and mike.



I learned that the Firebrier was originally outfitted with a Motorola Motrac two way radio. I found replacements online, and the exteriors of the head control unit, speaker and base unit have been restored, although I haven't done anything with the electronics (not sure if they work). The head control unit and speaker were mounted below the dash where the FC radio normally would be found.



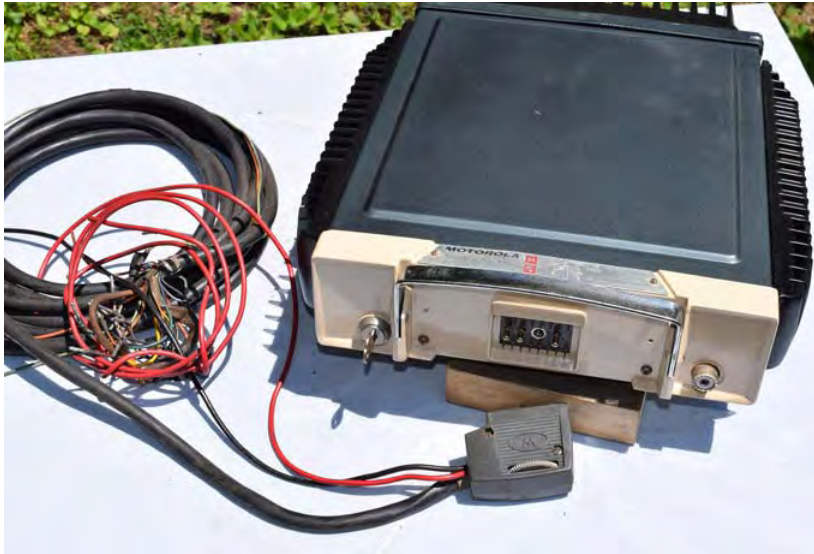

and the base use was under the front seat

I have a period appropriate "Antenna Specialists" mount for the antenna, but have not yet acquired the spring and mast.



Apparently, the Firebrier carried a full size 4 cylinder air cascade across the powertrain covers with the valves positioned facing the rear doors. This was used to fill the respirators during fire runs. The cascade probably weighed about 500 lbs and it's remarkable to think of the Firebrier so equipped running around the hilly Saugerties terrain. Might explain some sagging of the rear springs and the engine wear and tear. I have no intentions of installing replacements.

June 23, 2017

Working my way toward the front exterior of the Firebrier - it's a real pass-through van now:

Notice the great wheel covers to protect the white walls - HF, all four for only \$10! Lots of plastic to cover finish paint, etc on the interior. Roof is also primed and ready for finish paint.

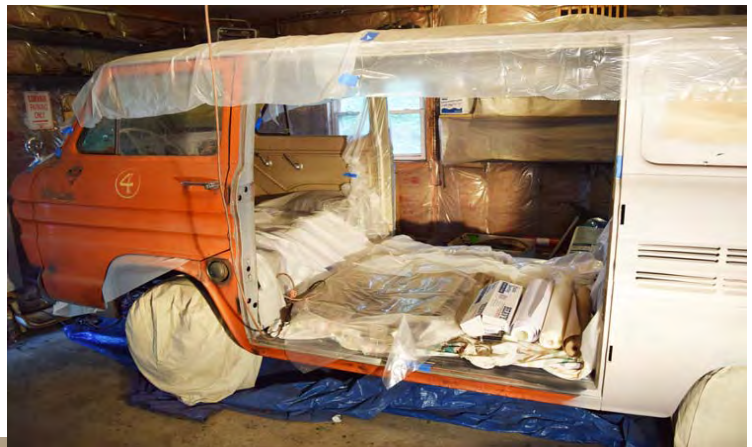

The side doors have been finished - always more work than expected; though compared to my 61 GB, doors of the Firebrier were in much better condition. Here's most everything in the lay down area, ready for reassembly

The door interiors are finished with fawn poly, but the exteriors are left with primer, to be finished with rest of exterior at a local body shop. All the components have been cleaned, stripped and painted. Lots of wire-wheel work, or media blasting in some cases or even the angle grinder for the hinges

All the screw heads and threads were cleaned, heads painted. Extra care is given to the door hinge bolts. 3/8 - 24 threads of the bolts and their holes were carefully chased. I fully degrease the door and window mechanisms, will relube with lithium grease when reassembled. Most of these still had good zinc coating, but a couple were repainted.

The doors themselves has a variety of issues; and here's a sampling of the repair work that was needed. The most obvious damage was the long indent and puncture to the outside of the right-front side door:

Like all the doors, this one was first stripped with aircraft stripper

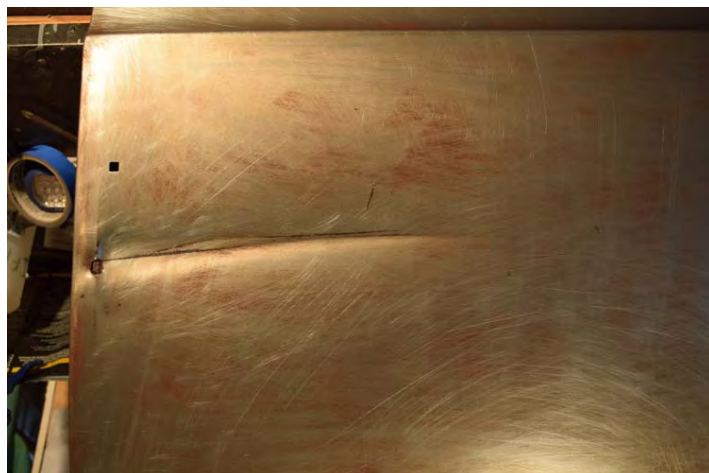

which shows the damage more clearly

This was another job for the stud gun, which allowed pulling out as best possible the indent. Unfortunately, damage like this extends much further across the door than what seems obvious from the gash itself, so even with the indent pulled out almost to the original level, a thin layer of filler will be needed to recontour the door surface.



to

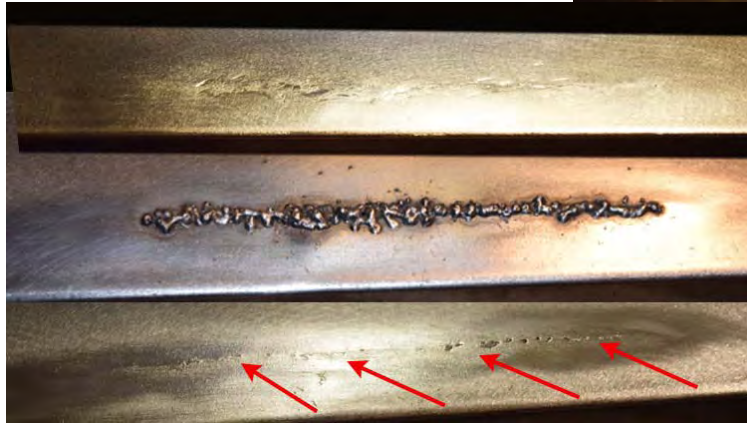

Careful inspection of any suspect area is necessary, and subtle rust damage sometimes is only revealed by using an aggressive wire wheel. For example, one door was found to have thin track of rot holes near the bottom edge, shown at the bottom of this image series:

I choose to carefully plug weld over the whole area and then grind smooth.

Replacing a large piece of the outer skin

seemed superfluous and likely to create bigger headaches. When done correctly, plug welding typically blows through any rotted metal and only fuses where the metal is adequately secure, and one only hopes that the result isn't a god-awful large hole that need to be welded closed. Fortunately, this repair went relatively smoothly. Speaking of door repairs, has anyone ever encountered a factory repair like this?



From the outside, the metal has a slightly different color, and on the inside we can see where a metal insert was welded into place. Mistake when punching hole for handle? Actually, this door has two repairs like this, and I wish I could do it so elegantly!

The bottom of the doors always are subject to rust damage and need to be carefully inspected. This image series shows, from top-down, repair of rot on one of the doors where the outer skin folds over the inside:

And this repair required drilling out the spot weld allowing the outer skin to be peeled back, the rotted metal cut out (second frame down), a refabricated piece welded in (third frame down), and weld ground smooth (bottom image). Unfortunately, the water drain outlet also had some rot (see arrow) that needed repair.

This was done by grinding an aluminum block to fit the inside of the drain, and clamping in place as a backer. Since the weld does not stick to aluminum, the gap could be plug welded and ground smooth, and the backer then pulled out.

Eventually, after necessary repairs, each door was sanded to bare metal with a rotary sander, wire wheel (invaluable for the jambs) and random orbital sander. Here's a door ready to be primed. A couple of the doors (like this one) had numerous small indents (banged by fire equipment?) that needed to be filled.



July 03, 2017

Seat reupholstery was done during the Independence CORSA Convention (which was a great event this year - well done HACO A!)

Firebrier came with only the front seat (apparently the single original rear seat, long held in an attic storage, had been disposed by the Home fire department only a few years ago). But Bill Clapper provided a replacement rear seat (two actually) - Thanks Bill!



The front seat and a rear seat were reupholstered by a local company; here's the rear seat restored (I plan to have the second rear seat reupholstered later, although I'm not sure if I'll use it in the Firebrier). The stock '63 FC standard seat upholstery was nicely prepared by Clarks to match the originals.



The frames were derusted (a tough task) and painted with gloss black enamel. I discovered that the burlap with woven wires, visible beneath the seat bottoms, was not commercially available, so I decided to reproduce it myself:

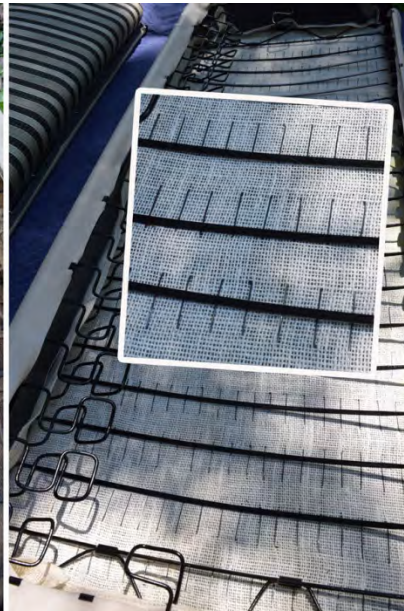

This was no small undertaking, I learned. For the wire I used 18ga piano wire, which was plenty stiff enough, but arrived coiled...

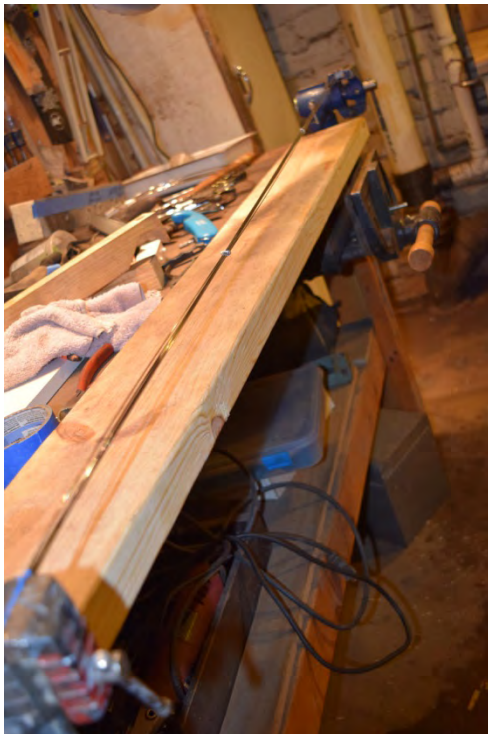

... and needed to be straightened. To do so, I cut the wire to appropriate length, and rigged up a system to pull bundles of the wires straight so that, progressing along the length, they could be heated with a torch and then rapidly cooled with a water soaked rag to retemper.

Several approaches were tried to weave the wires through burlap (from JoAnn's Fabric, and nicely cut and edge seamed by my lovely wife, Jane). Inserting the wires through accordion folded burlap was a disaster (at least visibly). And I finally decided to construct a mini-loom to hold the burlap flat...

...and mark the spacing on strips of 1.5" wide tape



Each of the 19 wires (per seat) were then individually woven through the burlap. Pliers were used to recreate the little bends on the ends of the wires, which eventually wrapped around burlap ropes (made from burlap stitched into bundles) to hold the wires in place. I found wire-woven burlap online for bucket seats of certain period cars (mainly muscle cars), but not in dimensions that would work for a FC bench seat. I think the end result came out pretty good.

July 07, 2017

Questions and Quizzes



1. What was the factory painting sequence for a Greenbrier that would leave exterior overspray under the interior paint? I finally remembered to take a pic, here as one of the front doors is being stripped, even though I have seen this on other internal surfaces. Below the fawn interior paint is cardinal red, only on the jambs and assorted protruding surfaces. Did the factory paint the van exterior and then mask and paint the interior??

2. Here's a tough nut - well actually a bolt: Ever notice that it's always the "last one" that causes the headache...well, maybe it just seems that way. This is the last of the 8 doors being disassembled before removal, and a bolt securing the vent window is inside the door accessible through this hole. And this d**m bolt was rusted tight in place. After two days of penetrating spray and persistent screw driver work, it would not budge, and the head was getting damaged. The bolt goes into a nut welded to sheet metal, so an impact driver was out, and too deep to drill and then use an extractor. The rest of the door cannot be disassembled without first removing the vent window, so I'm starting to think I might need to cut away the metal to access the bolt and then reweld back together, but then came a simple solution, and the bolt came right out. How would you do it?

I used a Smith mini torch, the white-hot flame directed through the hole directly onto the bolt head. When it was red hot, I immediately squirted water to rapidly chill it - the temperature shock freed the threads, and it easily came out with a screwdriver.



3. The Firebrier was almost encrusted with mudwasp nests, in every cranny, cavity, channel, crevice you can imagine. It was amazing how everytime I thought I'd found and removed the last one, another appeared. Well, working on the front right door, I found another, and (maybe) the last:



July 14, 2017

Another milestone! The last of the exterior paint has been removed and the entire exterior of the Firebrier is now primed.



After finishing the doors, I wrapped up stripping the rest of the cab. There were a few areas that needed body work - a couple days work - but nothing major. The final assessment is always done after the high build primer is applied. Hopefully sanding is adequate to remove defect, but if not, a little filler, resanding and then repriming will do the job. Considering how damaged were the corner pieces (describe previously), it was a relief that below the bumper the front body panel was in excellent condition, like new!

The inside of the cowl had lots of overspray, and I have gone ahead and replicated it now, masking the gas heater cover panel, which was (and is) black. This way when the exterior is painted at the shop, they can simply just mask off the cowl.

July 23, 2017

The side window lower sashes have been cleaned up. Overall they were in pretty good condition, little rust, and the setting tape and rain guard weather strip were still pliable. After stripping the remnants of the original paint and wire wheeling off any rust, everything was masked. The sashes were primed (self-etching) and then painted gloss black. Done, but the windows will not be reinstalled until after the exterior is painted.



The windshield wiper linkage rods also are also refreshed. The pivots were originally galvanized (or tern coated?), and they're now painted with Rustoleum matte nickel, which I used for all similar metal parts. The linkage rods are painted gloss black. If there's a trick to reinstalling these wiper assemblies please share it, because I find this really difficult, and inevitably involves dropping a screw or two into the black hole of the front cowl space!

All the doors have been temporarily reinstalled so that alignment and spacing can be established. Alignment of most of the doors was still pretty good, but these left side intermediate doors needed a lot of work. As it arrived, the lower hinge of the forward door was damaged. Someone had drilled out the pin and replaced it with something resembling a large nail. The hinge was restored with NOS replacement hinge leaf, bushings and pin. That was essential, but a lot more work was needed - I took a tip from assembly plant lore and used my HF press to bend the hinges. This worked remarkably well, and only slight bending was needed to get good alignment and gaps. Oh, those are foam insulation boards I've cut to fit the windows to keep dust out.



August 10, 2017

Headlight assemblies are ready for reinstallation when the time comes. The original headlight buckets were rusted beyond repair, and Mike Deklotz was able to provide nice CA replacements. They were thoroughly stripped, primed and painted with gloss black enamel. Mike was kind enough to provide all new adjusters, and I replaced one spring.



Replacement headlight harnesses came from Clarks, as did the directional/parking light harnesses. But replacing the sockets was more work than expected. Here's the back end of the directional light socket restored with the proper boot.

... but I wish I had read Jack Bacon's thread about his headlight socket repair to completion. I too discovered the hard way that the C6172 replacement sockets that Clarks sells for the taillights don't work for the front directionals. But that was that was just one of the problems.

The FC directional/parking light harness that Clarks sells (C9752P) has a couple of issues, which was surprising since it's manufactured by M & H, from whom I've always gotten quality harnesses in the past. As you can see that boot looks nothing at all like the original. Since Clarks' FC tail light wiring replacement harness (C5733T) comes with the correct boot, I decided use those boots instead. Then I ran into the second problem, the metal tangs of the C9257P socket simply snapped off when I tried to peen them over. (I've reported this to Clarks and they are looking into it, and they compensated for the problem.)



So I decided to use Clarks replacement taillight sockets (C6172) instead, and it wasn't until I had everything done that I discovered (as did Jack) that the bulbs wouldn't seat. As best I can tell, the problem is not the length of the housing per se, rather, the thickness of the socket rim and the recessed hole into which it fits conspire to prevent the bulb from seating. So everything was disassembled, and I substituted AutoZone 1157 bulb replacement sockets; the tangs on these also peened over and the bulbs seated just fine.

Part of the hassle in redoing everything was the need to carefully solder the wires from the C5733T harness directly to the contacts in the bulb socket. I did not want to have splices in the wires. And this had to be undone to remove the sockets. I can attest that the hassle factor is compounded exponentially by finally getting the wires soldered on and forgetting to first pass the wires through the boot as well as through a small brass sleeve and the spring that are parts of the contact assemble. UGH! Thanks to Jim Brandberg for working out a trade for the T3 bulbs I needed.

August 23, 2017

What's wrong with this picture?
Yep... the Firebrier is gone! Finally off to the body shop for finish exterior paint.

I rented a Uhaul trailer and made a cover out of a really big Harbor Freight tarp for protection against the elements, which



turned out to be blue sky and sunshine. If I had been heading straight to the body shop (about a mile away), I wouldn't have bothered to

make the cover, just waited for a clear day. But first I had to haul it about 60 miles to a State Salvage Inspection Station in New Concord OH, to have the VIN number verified. Yes indeed, the VIN on the tag and the frame agree. (Truth be told, this was the second trip for the Firebrier to the Inspection Station, but that's part of another story to be told later.)



And then to the Body shop. The New Wehl Body Shop painted my 61 GB, inside and out. The owner is a great guy. They're going to do the final block sanding, fixing any imperfections that I missed (I know there are several), and then paint the exterior. Even though I had paint mixed to match the original Cardinal Red, after seeing it in bright sunshine, I'm not sure it's

right. Fortunately, as for the 61, the shop is willing to paint a door a few times until I think the color is right. On one hand, this will be an easier paint job since the exterior is solid red (no white line), but also will require restoring the lettering that wrapped around on all four sides. I'll be posting about how the original lettering will be replicated later.

September 08, 2017

It appears that I have been sued by the Firebrier in the Washington County OH Common Pleas Court. Well, OK, actually no. But apparently this is the only way the Court system can record my application for an OH title for the Firebrier.

Since the Firebrier did not come with a title (something I have been very nervous about), I had to apply for one. In Ohio, the only way to get one when none exists is by filing for a "Court Ordered Title" through the Common Pleas Court. This has been a rather involved process.

Following the lengthy set of instructions - on which is stamped boldly "There is no guarantee that a title will be granted" - I had to file an affidavit. Included were officially-stamped documents I obtained from the DMV/BMVs of NY (where the Firebrier originally resided), FL (where it was purchased), and OH (where I'm applying for the title) showing that there were no title or registration records for this vehicle; plus documentation showing that there was no record of it being stolen; plus assorted other documents.

This then entitled me to take the van to the State Salvage Inspection Station to be inspected. Now this is what has created the problem from day 1. I learned from the very nice officer at the station that while it was OK to tow a vehicle to the station for inspection, it must drive into the garage under its own power. Now that posed a bit a problem, as you will recall the condition of the Firebrier on arrival. So I have had to do all of the restoration so far to make it road worthy to get it inspected so that I could get the title. And not knowing how well this process would work out, making the restoration investment has been... well, risky.

So as I reported previously, I rented a Uhaul trailer and towed the Firebrier up to New Concord OH. Now you might ask, what was it being inspected for and how knowledgeable of Corvair 95s are the inspectors? Very knowledgeable I was told. The inspection began with the very nice inspector looking at the VIN tag and stating "The VIN tag has been replaced", showing me the irregular blobs of weld on either side. I suggested that this was the way the VIN tags were originally attached, and that he may wish to compare the hidden VIN number. Which he did after I showed him where it is. He then proceeded to thoroughly look it over, writing down critical numbers - the engine code, the carburetors codes, the mileage, etc. Looking for evidence that the van had been stolen.

Here it is in the Inspection Garage.

So after retiring to his office for a while, we met again and I was informed that because the vehicle did not have a 17 digit VIN number, he could not do an adequate on-line search of its records. (Bear in mind, I had the affidavit, with all the official documents from NY, FL and OH; and also bear in mind that they "routinely" do inspections of vintage vehicles.) As a consequence, he would

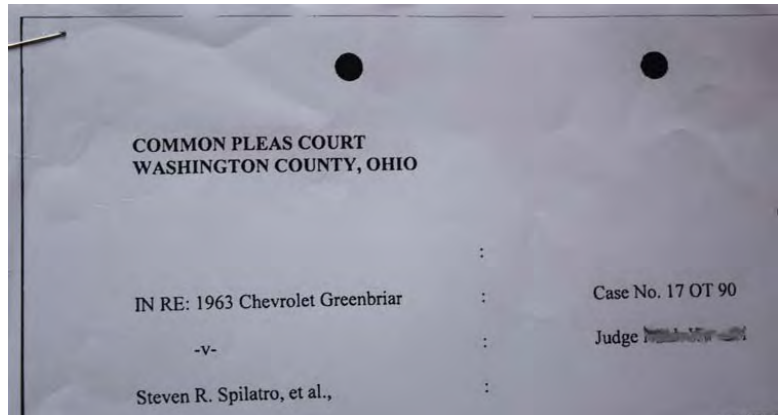

have to bring in from Columbus an "expert" who would somehow research the VIN in the deep vaults of official state archives. But I would have to bring the vehicle back for this to be done. I nodded and thanked him for the thoroughness of his work.

So, a week later we merrily uHaul the FB back to New Concord. where it was given a thorough 10 minute inspection. The "expert" looked at the VIN tag and the inspector looked again at the hidden VIN, and again confirmed that they agree. 20 minutes after that I had the necessary paperwork signed and sealed. Oh, on the way out the inspector asked if he could take a picture of the FB because his father use to own a Greenbrier.

With the affidavit and inspection now duly filed and secured, today was my day in court. I sat before the bench, the Baliff instructed everyone (me) to rise when the Judge entered, and then be seated. I stated my case, he agreed was justified, signed the Court Order for the title. We (me) all rose as the judge returned to his chambers. And I now have a title! total cost: approximately \$550 - not including the uHaul trailer. I'm not complaining, the system worked; but it certainly has its humorous side.



it

October 25, 2017

Some progress to report on color selection for the Firebrier. The Firebrier did not have custom paint, but rather "standard" RPO 514 - solid cardinal red. Standard in quotes because research has shown that cardinal red varied widely in hue between years, models and assembly lines. The Firebrier 514 had a definite orange tint somewhat faded, but not as much as one might expect based upon paint in some protected areas. I decided to look for a red with a



strong orange hue, but not so orange as the old paint.



The Firebrier will receive base coat/clear coat, since it's durable and offers the widest and easiest choice of colors. New Weihl Body Shop, which is doing the work, uses paints by Sikkens, which has a good quality automotive paint line and



provides chip books with thousands of colors. I was focusing on the reds of which this but a few of the pages.

Rick the shop owner, and the crew are great, and have been willing to test paint several colors. The first was distinctly too orange, although less so than it appears here.

For each color a test plate was also painted so that I could view the paint under different light sources. These were really valuable since the paints always looked more orange under shop lighting than sunlight... and most every other light source. The third try was met with approval. So now final block sanding and painting will proceed.

However, a separate metal plate is also being painted on which the gold-leaf lettering will be test painted, and I hope to be reporting on that soon.



Recently I received the rechromed parts back from California Corvairs:

Everything looks beautiful; flawlessly rechromed as best I can tell. I've always been pleased with the rechroming Jeff provides. Here's a closeup of the front flashers



You may recall these will be mounted on the front of the cab:



November 06, 2017

I recently restored the vent windows of the Firebrier, a job I find to be a particularly difficult. It's crucial that certain parts are installed at the appropriate time, and there are numerous opportunities to install components backwards. I strongly suggest photographing the vents thoroughly before disassembly to document orientations.

To disassemble the vent window itself from outer vent support frame, I prefer, removing the two rivets that secure the pivot hinge to the outer vent support frame. My advice is rather than trying to drill out the rivets, simply grind off the head or crimp and then punch them out.



I stripped old paint, derusted and primed everything. The window frame and black trim piece were repainted with Rustoleum gloss black paint, and the support frame and lower mounting bracket with Rustoleum Matte Nickel.



To redrill the rivet holes in the replacement channel, I inserted a wood backer strip in the channel and clamped it to the old channel to serve as a template; the wood strip helps when clamping the channels together, and also prevents damage to the felt lining when the new rivet holes are drilled.



During reassembly, having the correct orientation of the components will prevent later frustration (trust me!). Parts that must be oriented correctly are the black trim pieces, the molded weatherstrips (molded for either the left or right side), the special washer that limits window rotation, and the bottom mounting bracket.

To clinch rivets, I used both a center punch (to initially secure the rivet) and a Hanson HT-174 hand rivet clincher. I also used a small steel backer block to hold the rivets in place and to serve to counter weight the hammer strike when clinching.

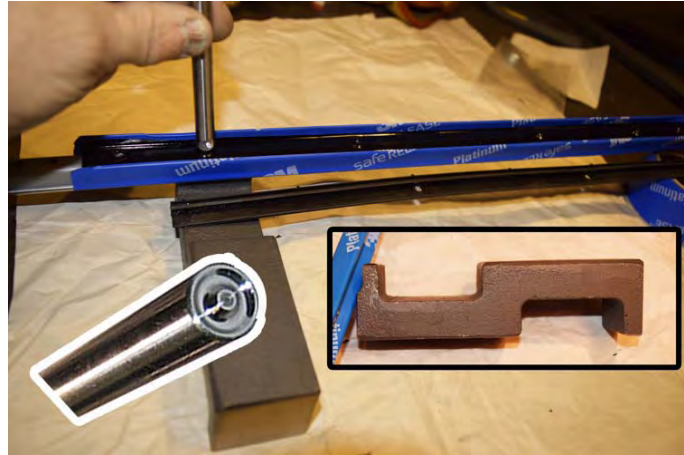

I found that if the rivets of the small vertical weather strip piece are over tightened, the weatherstrip will bow outward between the rivets (and everything must be replaced -ugh!). They should be clinched just tight enough to hold the weatherstrip in place.

Reinstalling the window into the support frame is tricky. The replacement molded weatherstrip was partially installed, next the window pivot post was pushed through its hole in the weatherstrip and frame, and then the window hinge was riveted back onto the support frame. I clamped the clincher into a vice and then carefully hammered the rivet heads to crimp them.



With the hinge secured in place, the rest of the weatherstrip can be installed.

The vent support frame and window was reattached to the channel, and then I attached the mounting bracket on the bottom of the channel. Because none of rivets from Clarks fit the existing holes, I used some slightly longer rivets and washers.



With the vents fully reassembled, the tensioning spring was reinstalled. Sometimes a little twisting is necessary to get the window to seat correctly, but the correct alignment of the support frame and channel will also be established when the vent is installed in the door. The Hanson hand clincher works really well. Here are two of the clinched rivets that hold the vent support frame to the channel; they look very close to the original, although the clinches are a little smaller.

November 09, 2017

When I rebuilt the steering linkage I was able to replace everything except the connecting rod assembly (draglink arm). Clarks carried everything except the long forward tie rod end - GM 3782920 or the Moog replacement (ES-633) seem to be unobtainium - although they offer a substitute complete



assembly that is machined from other parts. Miraculously I was able to find a NOS ES-633, and to complete the linkage, a NOS adjusting sleeve (3740858), and the short tie rod end.

However, the short tie rod end I obtained is ES-297L, which is threaded for proper turnbuckle action in the adjusting sleeve. Yet this table that has been posted before says that the short tie rod is ES-297R, which I would assume has the reverse

threading and thus would not fit correctly. Maybe the table is incorrect, or maybe the MOOG adjusting sleeve ES-312S is threaded differently than the original GM sleeve.

The boomerang was in good shape and didn't need to be replaced. Considering the Firebrier has only ~16 K miles on the odometer, no surprise the relay arm is in good shape. Dirty as all get out (but not as bad as some I've seen), and with a good tight idler joint; the center pivot moved smoothly with new grease. It was cleaned, primed and repainted.



The arm was painted with Eastwood Spray Gray and the mounting bracket with Blitz Black; the rear caps of the idler joint and center pivot were painted with Eastwood Detail Gray.

September 14, 2017

I decided to repop an actual stock GM FC front mat with the original embossed pattern. This was not simple since a NOS mat wasn't available and I had to work with a used mat. I decided to use the Firebrier's original mat, which was in pretty good shape. However, to make the mold the mat must be glued perfectly flat onto a surface, which is very difficult to achieve since used mats always have entrenched folds like these ...

... that will not flatten. The only solution was to cut out all of these areas and replace with new rubber cast with a matching pattern.



So after this was done and the original mat was repaired and secured down, a huge epoxy mold was made.



I used a clear epoxy so that any bubbles or problems could be seen and corrected before it set up. This stuff was really expensive, and you're seeing the successful result on the second try (the first attempt was a disaster of proportions I prefer not to discuss). Once the epoxy mold was separated from the template mat, further corrections and repairs were made. From this a urethane rubber mat was cast.



The rubber is quite flexible but of a strong industrial grade that will hold up well. I believe the repro is very good and is a little thicker than the original. There are some minor surface imperfections, such as these:



November 17, 2017

The Firebrier will also have a newly reproduced rear (load area) mat. to accompany the front mat that was previously reproduced.

Repop'ing the rear mat was challenging due to its size (60" x 69") and lack of a good quality original.



Much thanks to Dale Dewald for providing a used mat that was good enough. The forward area was in rough shape, and rearward there were many lost pieces and tears.

First I had to build a large flat reinforced platform upon which the mat could be secured. As for the front mat, flattening the mat is essential. This is the bottom of the platform



The mat was then glued to the surface of the platform, annealing the tears as best possible. Then all the damaged areas were carefully patched with pieces cut from other mats. Here's the forward area after restoration. Most of this was replaced with a chunk of the mat from the Firebrier. That's a level resting in the center of the mat.

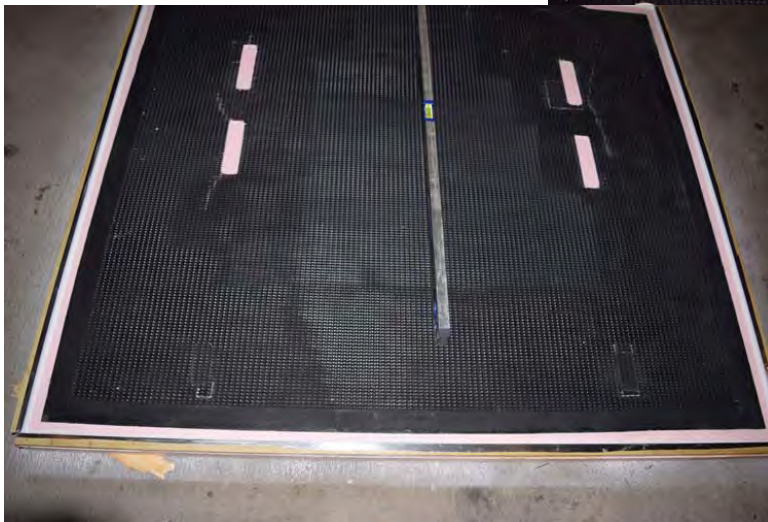
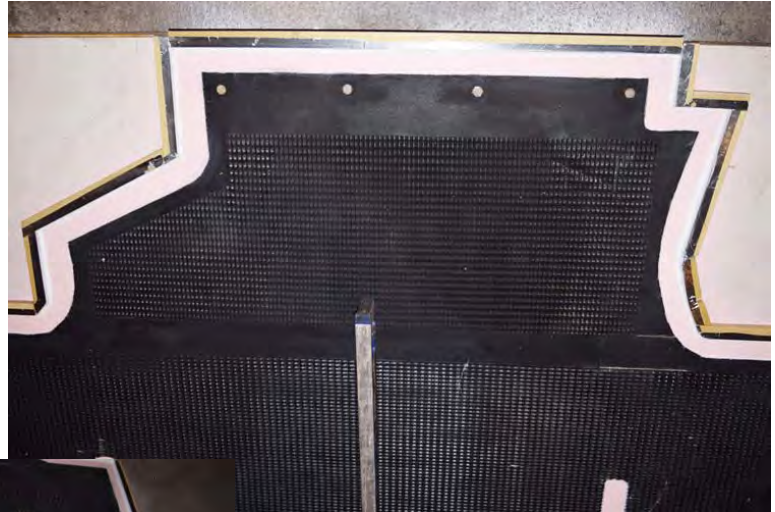

In the rearward area, especially around the seat mounting bracket cutouts, old damaged mat was cut out and replaced. You can see a white putty that was used to fill cracks.

As you can see, a wood frame was constructed around the mat to retain the epoxy used to create the mold. The mat was sprayed with a release agent, and then covered with several gallons of epoxy, which was allowed to cure for 36 hours.

However, before the epoxy was fully cured, the mold was very carefully separated from the mat. This is best done while the mold has some flexibility.

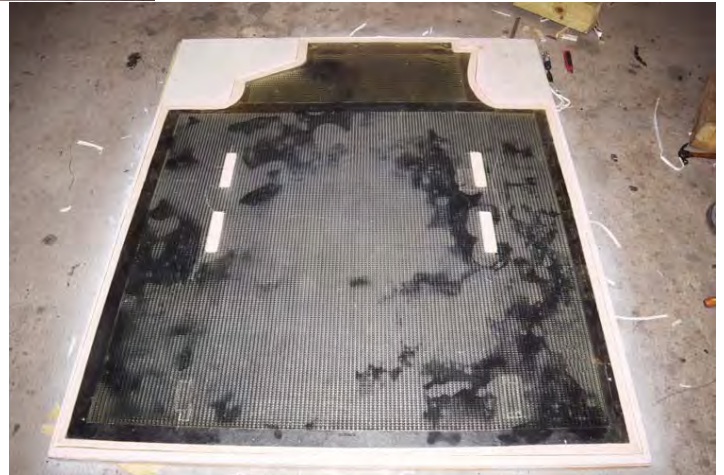

The next challenge was to flip this huge mold over without breaking it. To do so, another flat panel was clamped over it, so that the whole platform could be tipped up. . .

. . . and then lowered upside down, releasing the mold onto the second panel,

which was then moved back onto the platform.

The next step was to make repairs in the mold. Seams along the edges of patches, particularly in the mat borders, are visible and I have worked out a technique to essentially make these disappear. Finally, after shimming to get the mold perfectly level, and applying a release agent, the mold was cast with several gallons of an industrial grade urethane rubber:

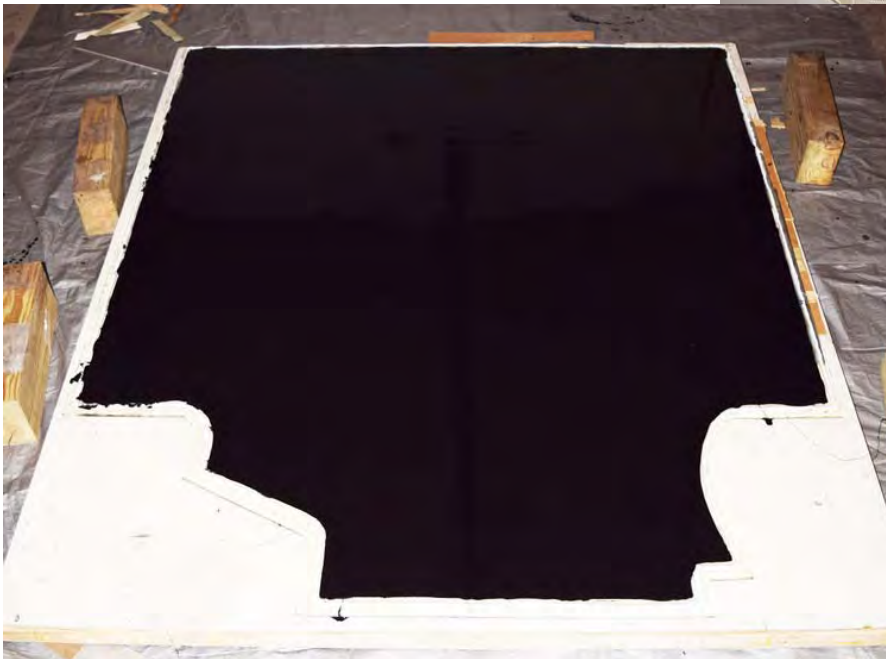

Which was peeled from the mold after 12 hours of curing.

The repro mat is shown in the first image, and I believe it's even better than the front mat. The openings for the mounting brackets for the rear (third) seat, are an optional cut out.

November 19, 2017

Back in a February post I had shown how a number of parts were given a new rubber coating (clips, spark plug wire retainer, etc.). Here's another one. Beginning in 1963 the rather elaborate checkarms of the FC rear engine access door were deleted (cost savings) and replaced with chains. The chains were originally rubberized, most of which was gone from those of the Firebrier.

Having some extra polyurethane from the aforementioned projects, I used it to recoat the chains. It takes a bit of work to adequately clean and derust the chains first (tough to use a wire wheel), but end result resembles the original.



December 01, 2017

The finish body work on the Firebrier had begun in earnest at the New Weihl Body Shop. Both the owner, Rick, and his brother Glen are on the job.

The first stage is to do several rounds of block sanding. The black paint is called a glide coat, which is block sanded to reveal any low points and dimples that will need to be filled. And they have found several.



Here's Glen blocking the right side. (It's called block sanding because a long-rigid sanding 'block' is used.) Even the door that was test-painted to select the body color has been block sanded.

The system for repainting the lettering has also been "dry-run". Special gold enamel will be used, sprayed on stencils that reproduce the original lettering.



I forgot to photograph the stencil, an adhesive vinyl into which the lettering was cut in negative, that I created for this trial, but here is the successful end result. Part of the skill I had to learn was how to apply the stencil so that it can be repositioned as needed. I'll show the details when the final lettering is done.

December 14, 2017

Side and rear door check arms have been cleaned and restored. Here they are almost ready for installation.

4 long arms for the side doors, two short ones for the rear doors. The check arm retainer plates have been done as well, painted black on the back sides as original. I spent a good hour frantically searching for the rear door retainer plates, mystified why they weren't with the arms, and thinking the garage gremlin had struck again. And then remembering that the retainer plates had been eliminated from the rear doors in '63 (unlike my '61 GB that has rear door plates). Add searching for nonexistent parts to the list of time-eaters.



Here's one of the unrestored arms.

I failed to photograph a retainer plate before stripping, but these too, like the mounting bracket of this



was arm, were painted body red. Which is interesting since it means that the check arms were installed, and partially masked, when the door jambs were painted. I wonder if the retainer plates are painted body color in other FCs with original paint – can anyone check?

As I worked on the arms it became clear how hard it would be to strip and repaint the spring area. Could be media blasted, but that doesn't help when repainting. So I decided to dismantle them, which is actually not that difficult.

As shown here, the check arm assembly is held together by a metal pin that is slightly flared at one end to secure it in place. I realized that the flare

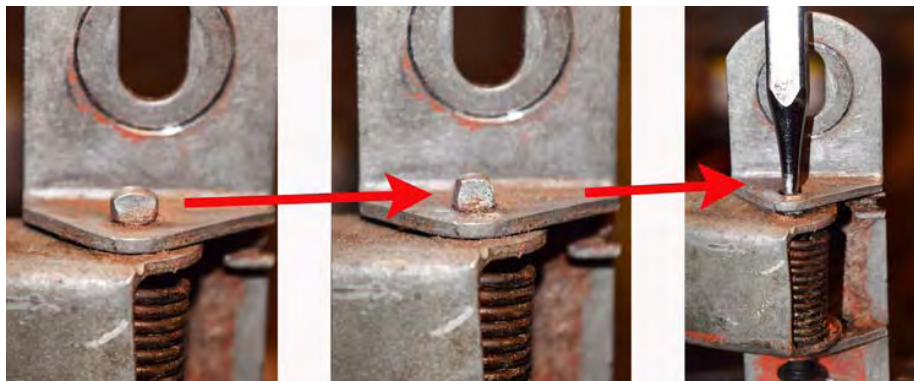

can be easily ground off with a Dremel tool, allowing the pin to be punched out and separation of the arm and mounting bracket. When the check arms are reassembled, the pins can be easily reflared to restore the original appearance.

So here's everything separated and stripped.

Though no serious rust, I did first electrolytically derusted several parts first, and then everything was wire wheel stripped to bare metal. Several of the pins were bent, and these were straightened. Since there is no practical way to remove the rubber wheel, stripping under them took more time, and they were masked before painting. The retainer plates above are fitted with wires by which they can be suspended when painting.

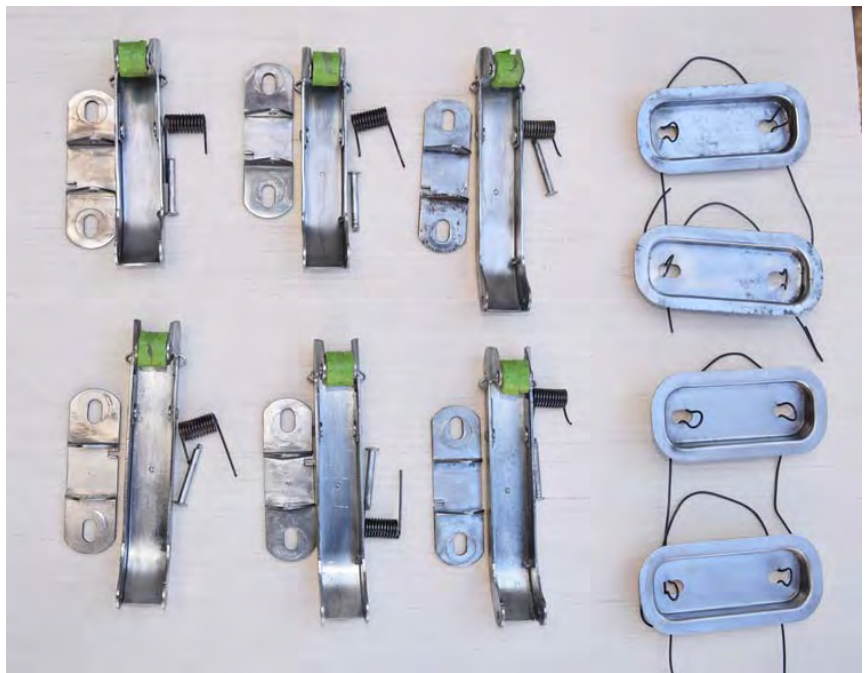

I used a large painting frame and lots of 22 gauge wire to suspend everything for painting. First painted with self-etching primer, and then with Rustoleum matte nickel enamel, or with Black Blitz for the back of the retainer plates.



After everything was painted, the arms were reassembled with the pins inserted through the springs – takes a little manual dexterity. Then working over a small anvil, and using a metal punch and hammer, the ends of the pins were re-flared.

Here's one after a little flattening. Fortunately it doesn't take much flare to lock the pin in place.

December 30, 2017

Progress and a setback in Firebrier restoration.

The finish painting has progressed, and shown here is the base paint applied to left side and rear, with the plan to paint and apply the lettering in stages.



The base coat on the rear quarter panel has been scuffed to facilitate adhesion of the gold lettering enamel and then the subsequent clear coats. At least that was the plan.

The original lettering is going to be replicated as closely as possible. The lettering had been originally hand painted with gold enamel (the original brush strokes were still visible).

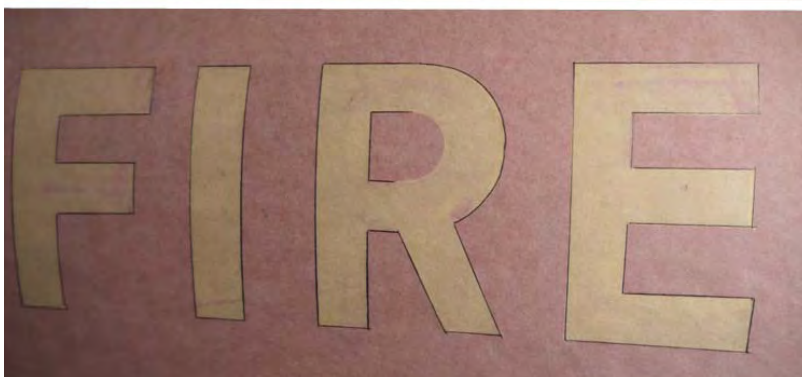

Preparation for relettering began shortly after acquiring the Firebrier by copying all of the text on tracing paper using a straight edge & French curves.

Overall, there are 11 text panels: 8 doors plus the front and two rear quarter panels. The tracings were then used to cut stencil silhouettes from adhesive backed vinyl.

Here's the stages for one of the fire company vehicle numbers on the front doors.



The stencil was cut using the tracing as a pattern, and then after the backing was removed, the vinyl was applied to the panel. The panel and vinyl adhesive side were first sprayed with soapy water, which allowed repositioning as needed, and then the vinyl was squeegeed to remove water and secure it in place. Then any support arms are removed.

Overall, 5 panels were applied; here's the vinyl applied to one of the rear doors:

All went well through the painting... until the vinyl was removed...



...when disaster struck. Unfortunately the vinyl adhesive reacted with the scuffed base coat and would not come off. If you look closely, you can see the adhesive around the letters; the vinyl adhered so tightly that in one place it pulled off the paint. So all the panels will need to be resanded and repainted. Bummer on several accounts.

This is a great example of trying to anticipate potential problems, but missing one of them. Even though we had shot a test panel and all went well...



... the lettering in this case had been painted over a couple of clear coats, and then reclear-coated several times. However, the lettering was still somewhat raised, so we decided to apply the lettering directly to the base coat; which was scuffed to assure adhesion of the enamel and subsequent clear coats. Obviously a bad idea. Oh well.

Rick, my body shop guy, believes that he can reproduce all of the original panels almost exactly using his lettering software and computer-guided laser vinyl cutter. In some regards this can yield a better final result. He is going to prepare a test panel and we'll then decide how to proceed.

January 03, 2018

So, we're getting back on track, the damaged paint and lettering on the side panel and most of the doors have been removed (all the way back to bare metal) and reprimed. The consensus view is that the first attempt failed because the base coat had not adequately cured (lettering had been applied after about 18 hours).



(somewhere under all that masking paper is a Greenbrier)



All the lettering is going to be redone by computer and the stencils prepared with a laser vinyl cutter
As you can see, Rick has achieved a good match to the original letter font; a little bolder. It's also a much cleaner cut than what I had obtained cutting them by hand.

January 23, 2018

The sections were stitched together in Photoshop, and the image was then used as a background from which a vector outline was prepared in Corel Draw, the vector image was then filled black. This was done for all 11 stencils, and the files were passed on to Rick (my super body shop guy), who then further cleaned up the edges with his software before cutting the stencils. As a result, the letters have much cleaner edges than what I had achieved cutting them by hand.



All of the areas that were previously lettered had to be sanded all the way back to metal, and then repped. The lettering base this time was on clear coat that was lightly sanded. This is to assure adhesion of the gold enamel as well as the subsequent clear coats.

Rick's vinyl comes sandwiched between upper and lower backers. The lower is peeled to expose the adhesive. Here is one piece applied, but with the upper sheet still in place,

All the doors are being lettered off the the vehicle because of the impracticality of painting them on the hinges. I spent several hours carefully measuring (and remeasuring) to position stencils correctly, and then squeegeeing them into place; a lot of guide tape was used to maintain alignment.

I asked Rick to double check all measurements - a good move since one was slightly misplaced. And thus another advantage of laser cut stencils... screw it up? - just peel it off and cut a replacement. When the stencils were secured, the upper layer was removed to expose the stencil for painting.



And so they were, beautifully done, and the vinyl came off without a hitch.



I'm really lucky to have a first-rate body shop guy. I have no doubt that he is as concerned about the final result as I am; never a complaint when we've run into problems, and always the attitude that it will be done right.



I've come to appreciate the skill with which it was done, including the sizing and layout of the letters.

Consider the lettering on the rear...
...with "EMERGENCY" displayed evenly across the doors. The visual symmetry was achieved even though there are four letters ("EMER") on the left door and five letters ("GENCY") on the right door. This difference is not apparent to the casual view because the size and the spacing of the letters is almost imperceptibly altered to create equal sized margins on either side of the word.



I found subtle differences in letter proportions on all sides. This is one reason why it would be difficult to replace the original lettering with a modern, standard font.

Next up: The surface of the lettering will be lightly scotch-bright pad sanded before clear coating. but before clear coating the roof will be finished. We're applying 5 clear coats, with sanding after the third.

January 31, 2018

Five clear coats later.

The doors are spread out over a good stretch of the shop - I'm not sure many shops would even consider dedicating this much space to one vehicle. Rick says finds time as he can to work on the Firebrier - lots of fender-bender work coming in these days. So he's been sanding and buffing as time permits; lettering looks, well... tremendous!



he

Ever since one of his employees left a couple of months ago, Rick is working short-handed. He says it's getting harder and harder to find skilled auto body technicians - maybe soon a lost craft.

But getting the doors back on certainly is a priority, so he's looking at painting the hinges ASAP, and I'm going back tomorrow to fit the door hinge grommets.

February 10, 2018

There's a Firebrier under there somewhere
Rick seems to have an endless supply of masking plastic, paper tape, etc. When I paint back home I always seem to be scrounging, which is a pretty silly way to operate considering this stuff doesn't cost all that much compared to, say, the paint!. And red paint is particularly expensive.



At any rate, doors are still not yet installed but everything else is well protected while the roof is painted.

Among the several reasons I'm disinclined to do the finish exterior painting is the difficulty painting such a large expanse. Rick does it without the benefit of a rotisserie, propelling himself along on a wheeled cart. Done perfectly.

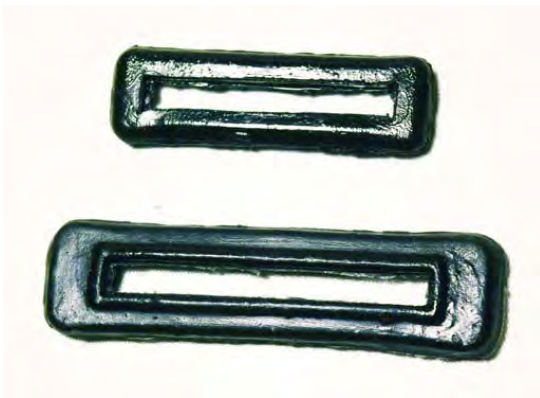

I went in to fit some door grommets. These are an item I make myself (been selling them on ebay for a while), made from the same tough urethane rubber used for the floor mats.

I started making them myself because I found the silicon rubber alternatives tend to rip when the hinges are installed.

And this is a particular problem because on some doors the internal frame is positioned so close to the hole that there's very little room for the internal flange of the grommet. I'm not sure how the factory fit the original grommets (wish I had looked more closely when I pulled them off) with such constraints, but on my '61 GB in these situations the grommets often became damaged and would not lie flat.



My solution this time was to make some custom grommets with extra thin flanges on the back side (the bottom one in this pic): which, with additional extra trimming, fit cleanly into these extra tight holes.



And all were tested by sliding in a hinge. Although the original grommets were painted, these will be left unpainted. The paint is very unlikely to adhere for any period of time, and eventual chipping would look awful.

The dash still needs to be painted, and various small parts. And I'm getting excited about soon seeing the Firebrier, doors reinstalled and lettering all the way around.



February 24, 2018

Déjà vu. The Ohio River will be threatening Marietta again in the next few days and most of the downtown businesses have cleared their first floor. Last week, at 39 feet (4 feet above flood level), water was just beginning to come up from the floor drains. This time the crest is projected at between 41-44 feet. Rick has cleared much of the shop and put the Firebrier up on a lift.

A few shots:



Between previous and anticipated floods, the dash was painted. Rick inspecting; no shortage of masking protect interior and exterior paint, and the front seat upholstery.

And after painting dash and instrument panel.



to

However, I did take the opportunity to create a panorama view of the undercarriage (photomerged together). You can click on the image to see an enlarged version.

March 05, 2018

A Marietta-Firebrier update. The flood projected for last weekend was a complete fizzle. The crest, initially projected for 44 feet was reduced to 39 feet, and then never exceeded flood level (35 feet). But not before all the downtown businesses semi-ed most of their merchandise to higher ground. We're all glad the town did not flood, but



it's

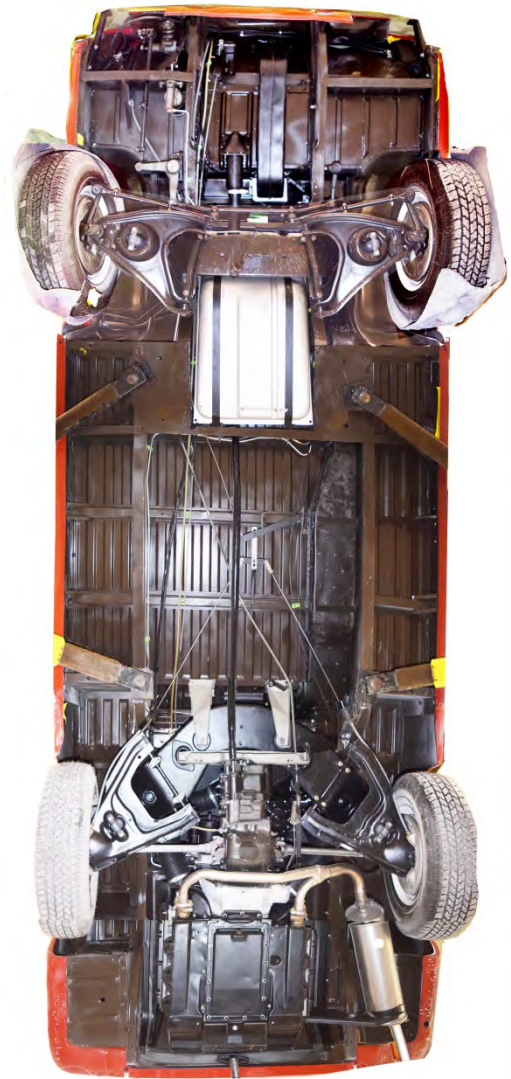

discouraging that the actually crest was 12 feet lower than what was originally projected. I know flood projection (like the weather) is notoriously unreliable, but but also wonder if the National Weather Service (responsible for flood projections) is another federal agency suffering under-funding and under-staffing?



Doors are on and I think the lettering looks great.

I was awaiting this with excitement, and some some trepidation, fearing lettering would not line up, or - nightmares of a worse case scenario - doors received wrong lettering. But with the doors on the lettering aligned just right.

Lettering on back doors, exactly as originally painted:



But there's also been a setback, necessitating a lot of remasking:

When I looked at the inside of the doors, I found that the exterior red paint had been allowed to overlap about 3/16 inch on the inside of the doors:

which, not only wasn't how it was done

originally, but to my eyes, looked weird.

I'm not sure if the FC doors were always painted the same way, but on the Firebrier, the interior paint extended to the edge of the door. Fixing this is going to entail a lot of time remasking just to paint over a thin line of red paint.

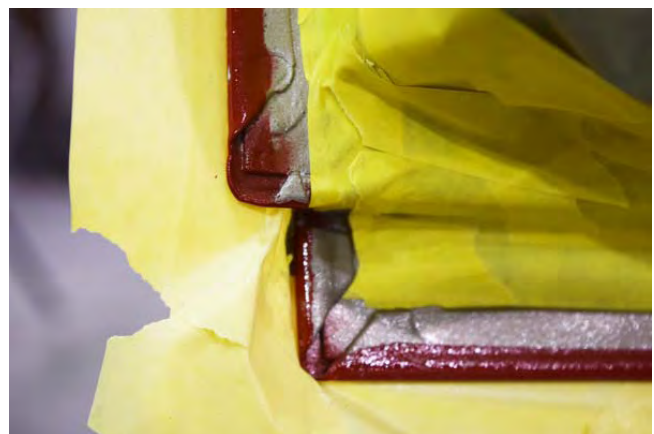

March 08, 2018

Repainting the door edges is taking a lot of work, and time. I thought I'd mention, as shown above, each door interior must be carefully masked along the edge of the outer skin, and the outside masked but with the tape extending flat from the door edge (not wrapped tight), to avoid getting a hard edge between the interior and exterior paints.



But in the interim, I've cleaned up the instrument panel:.
Note the cigarette lighter hole cover plate.

Overall it was in petty good shape. The frame paint had taken a beating below the ignition switch and headlight switch. So it was sanded, primed and repainted:



and everything else was cleaned, and the chrome parts buffed.



The speedometer looks to be in great shape.



Likewise for the odometer, showing the original 15882 miles, with no evidence of the typical flaking of the numbers.

March 11, 2018



This hopefully should be the week the Firebrier comes home. Repainting of the door edges is almost done, and just a few items left to paint (cab front corners, engine grill, steering wheel, misc small items). The plan is to paint the steering wheel to match the dash (as it should) but to flatten the paint.

Meanwhile, another item checked off the to-do list. The horn, provided by Eric Prosis, is refinished, and I thought I'd show pics of each step.

The original condition was mixed - the front was pretty good, still had original paint, but the back side and bracket had a lot of surface rust.

Its a tricky item to strip, with all those contours, crevices, nooks, etc. I started with aircraft stripper, then several rounds of blasting and wire wheel work. But eventually, I got it down to bare metal. The throat was sealed with a wad of cloth, and the inside of the horn trumpet (mouth) was stripped as well.

After wiping down with degreaser and then propanol, the horn was primed with several coats of self-etching primer. And then finally, the finish coat was a gloss black enamel.

OK, another part ready to install - just need the Firebrier to install unto.

March 16, 2018

The Firebrier has returned home! I can only wish everyone has such a great place to have your Corvair painted.

The Firebrier arrived at the New Weihl Body Shop last August. Here's Rick (right, the proprietor) and his brother Gene, two great guys, who worked on the Firebrier, on and off, for almost 7 months.



There were a lot of issues and problems to be solved, the lettering being just one, a couple of threatened floods, and an occasional need to repaint something, and the final cost was the same as originally quoted.

Gene doesn't believe I can complete the assembly without scratching something, and has offered to fix any such problems later.

Since I would have to go all the way to Parkersburg WV to rent a Uhaul trailer, Rick brought in his trailer to help bring the Firebrier home.

After some initial difficulties figuring out how to strap it down (Rick's trailer is somewhat short on hooks) we got it ratcheted adequately for the long, 1.5 mile trip across metro Marietta.



And here it is, before and after, in the garage.

March 20, 2018

So the headliner is on hold until I reinstall custom wiring to rear flashers, beacon light, antenna, etc., which will be run behind the roof crown molding. So I decided to get out of the way the dreaded reinstalling of the front door windows. I don't know if there is an easy way to do this, but after two FCs, I



haven't discovered it. The diagrams of the assembly manual seem to be designed only to show where things attach, not the actual assembling sequence itself. Some steps must be done in a specific sequence, and I would really like to know how it was done originally on the assembly line.

At any rate, here is the process and steps that I have worked out; still not easy, and for me, required about 2 hrs per side. Pictures illustrate some key steps. My advice is to only loosely screw in bolts; and the do the final tightening later.

1. Fear of scratching the paint adds to the stress of installing the vent window, so I play it safe, and tape the edge and protect the outside paint against accidents.

2. Now's a good time to peel back some of the paper and install the outside rear view mirror bracket (should your FC have one). This must be done before installing the vent window.

3. I already had the door latch mechanisms installed, so next the window regulator goes in; again, a must-do step before installing the vent.

4. Next is the vent, a truly grueling process. It must be worked behind a metal flap on the door inner skin and then forced into the upper track of the door, where it doesn't want to go. All the while try to avoid scratching the paint, getting the rubber tucked correctly, and the whole thing positioned correctly.

5. And correct positioning means that all the screw holes need to line up. There are three through the upper door jamb which are particularly annoying. And the lower track extension will need to be aligned via hand from within the door - be sure to get those two lower screws in before inserting the window.

6. This is the last opportunity to install the outer fuzzy. If you forget to do this you will need to reinstall everything back to this point – trust me on this!

7. Installing the glass, the outer track and the channel liner is very tricky. I had installed original steel-backed channel liner when I had restored our 1961 GB, but now Clarks only sells the flexible rubber style. I was concerned about how this would install and appear, but it

looks pretty good; however I have not actually cemented the liner to the track yet, should I decide I don't like it. At any rate, first install the window so that the forward edge is in the track attached to the vent window. Now insert the channel-liner in the removable rear bracket, and slide this all the way into the door alongside the glass as shown in Fig. 7.

8. Now feed the channel liner into the track above the window, and pull the window up into it. Now, metal bracket so that the window can be lowered back down into the channel. With some fussing, you can insert the two screws that hold the lower track to the door jamb. The liner may need to be adjusted at this point to straighten it.

9. After the liner is trued along the entire length of the track, the excess on the upper end can be trimmed off.

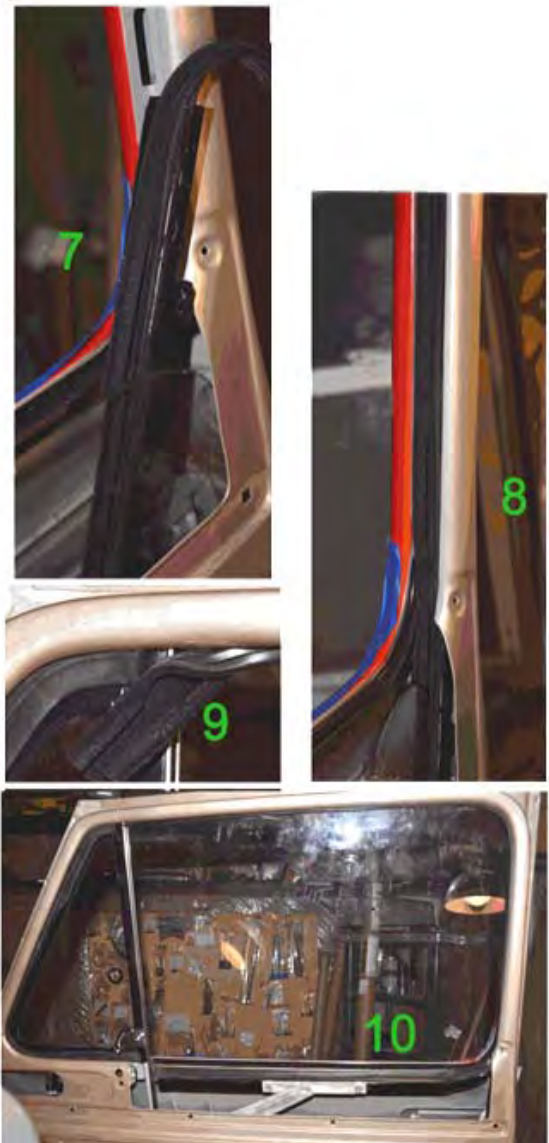

10. Now it's just a matter of rolling up the window regulator so that the nylon roller can slipped into the sleeve that then bolts to the lower edge of the window. Tighten all the screws making sure that the window rolls up and down smoothly.

March 27, 2018

Here's a little piece of unobtainium I picked up a while back.

A NOS Delco Series 53 FC battery. Part number 556 is embossed on the side, but with a 557 label since it's a dry version (acid has not been added).



Here it is placed into the battery compartment. A test fit.

A test fit because things are not what they appear. The last thing I want to do to a NOS 557 battery is add acid; causing it to soon be just another used dead 556 battery. No this will be for show only. Hidden below is

the real battery, a modern 51R.

It fits into a custom made frame made of perforated angle steel. You can also see a cut out in the frame to allow reinstalling the battery drain tube and grommet from the upper battery shelf. This is a preliminary version that was later modified with addition of steel straps under the battery





The frame is secured to two body panel bolts that stick up from the floor of the battery compartment floor. Placement is designed to make this battery as hidden as possible. The Firebrier also has cold weather air baffles on the sides of the engine compartment, and the left side baffle also helps obscure the 51R. Shown above is the positive battery terminal that has a twistable cut off switch. This way I can reach down and disconnect the battery without pulling out the upper

battery.

The two batteries will be grounded to the body in the same place, and the two positive cables are linked together. Here is the custom battery cable "T" connector I made.

Three battery cable lug ends were soldered together, and crimped onto the battery cable. Then the whole thing was covered in rubber to insulate it. The location of the T-junction is also rather hidden.

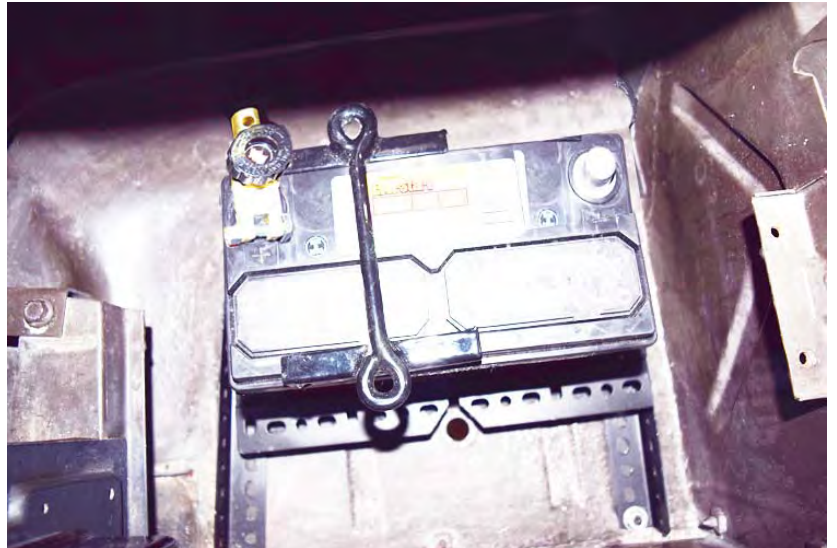

The end result is the appearance of a functional series 53 battery but with power actually coming from the hidden 51R

April 14, 2018

I decided to install the weatherstrip on the rear doors. My advice to anyone installing weatherstrip is to make a jig that you can use to make 45° cuts.

This is mine and it's essential to get good corners. Also, It's a good idea to wipe down the weatherstrip with isopropyl alcohol to remove any remaining release agent.



This is mine and it's essential to get good corners. Also, It's a good idea to wipe down the weatherstrip with isopropyl alcohol to remove any remaining release agent.

Something I noticed when I removed the original weatherstrip was that the corner seams were reinforced with a "L"-shaped rubber insert. I had never seen this before and did not find it in the assembly manuals, but it must be original, so I decided to reproduce it.



Sized to fit the larger weatherstrip inner hole, with some weatherstrip applied inside and on the cut surfaces, they work marvelously to hold the corners together while the cement dries. They are really useful to temporarily hold the weatherstrip together when making preliminary cuts. I use them to cut and cement together the weatherstrip for a door before installing it.

The result is nice clean secure corners. I've not seen that these are available anywhere. Is there any interest by others in using them?

A final note. One of the tricky parts of installing weatherstrip, Is applying the cement on the rubber and then not having it get stuck on something. My solution is a tall pole and a string that I use to suspend the weatherstrip as I install it.



April 21, 2018

Front air vent flapper doors - today's project. Firebrier's were structurally sound but with a lot of surface rust.

First step was to remove the old rubber seal, and then the doors were juiced in the electrolytic deruster tank overnight, wire wheeled to remove residual oxide, primed and painted. Now ready for replacement of the seals.

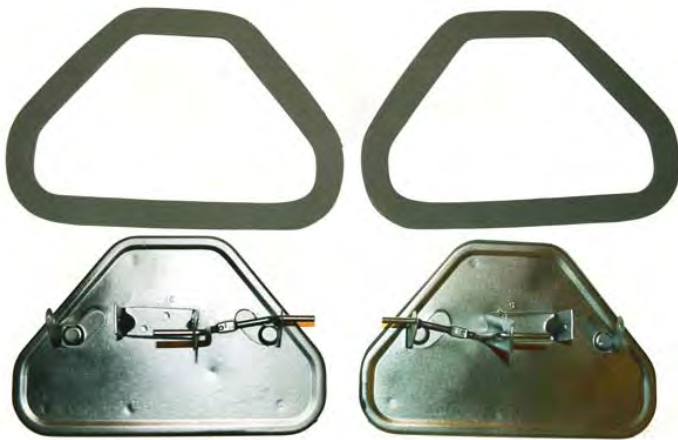

Clarks sells new rubber seals; with a note that they're easy to replace, but not so. The instructions provided are correct as far as they go. To replace the seals, you need to carefully pry apart the two metal plates that comprise doors and hold the seal in place.

But this is a darn hard task since the metal plates do not separate easily along certain sides of the door. The task was accomplished using a couple of little screw drivers and carefully fitting in the seal while working around the door. But oddly that is

where Clark's instructions end, which leaves the rubber seal extending flat from the sides of the door - which will not allow the door to close. In order for the door to be functional, the seal must be folded back upon itself at two points so that it curves away from the door in opposite directions on different edges. On the original doors the seal is cemented where it folds across, as shown in the image insert below.

Recreating this is the tricky part. I had dealt with this problem when I restored my '61 'brier a half dozen years ago, and fortunately I still had the simple tool I made for the task.



It's a 1/2" aluminum metal strip bent to follow the contour of the door then pulled tight to hold the rubber seal in the needed contour. I apply a little weatherstrip cement in the fold. I also apply a little paint along the folded edges to lock them in place (I have always used POR 15 for this because it works, but maybe any type of enamel would work as well). Here's a completed door.

When installed, the fit into the door opening will lock the contours of the seal in place permanently.



April 29, 2018

Rear Inner panels are prepped for installation. Painted long ago, this weekend I completed installation of seals and sound insulation, identified as #1 (sound insulation) and weather seals #2 & #3, plus the small "D-shaped" weatherstrip shown in this pic.

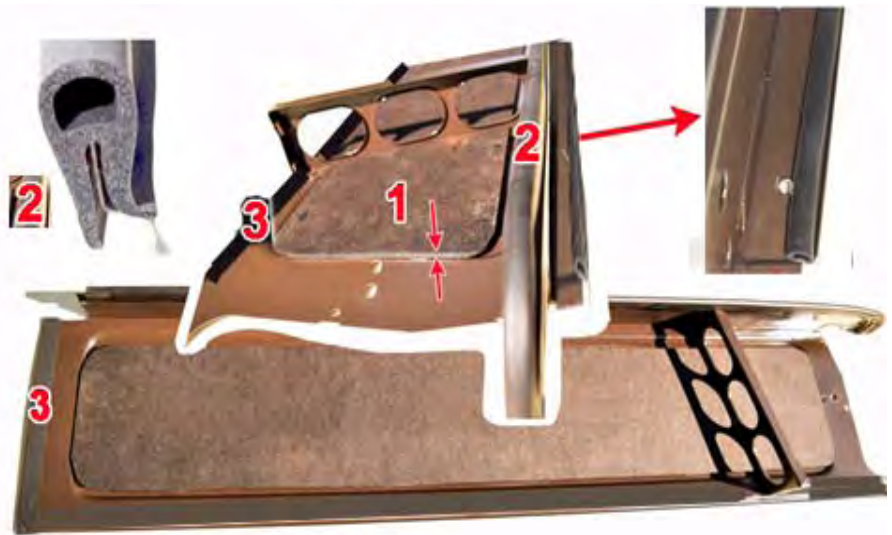

Unfortunately, none of these are available from any of the Corvair parts vendors, so I found or made replacements. For #2 I used Soffseal #9347 (1960-66 Chevy Truck front fender to cab seal); the original was stapled on, but I decided that would have been unbearably difficult, so I used weatherstrip cement. #3 is a strip self-adhesive neoprene rubber, 1/8" thick by 1" wide. This is a very close match to the original, maybe just a little wider but fitting the space nicely. Short lengths of both are also needed for the rear corner inner panels.



The most difficult item to replace (if you want something close to stock) is the sound insulation (#1). The stock item was an asphalt impregnated fiber panel about 1/4" thick, which was notorious for peeling off and blocking air flow to the engine. I could find nothing similar, but the solution came while speaking to Clarks about the extra thick tar paper sold as front mat underlayment, which I learned is made in-house by cementing together two sheets of tar paper. I decided that



if two sheets could be cemented, why not four?

The final dimensions of the sound insulation is 8" x 48", cut into two pieces that straddle the brace. So I started with 8 pieces cut 8.5" x 49". The cement is C3735 (carpet glue), which I applied to both surfaces to be adhered. Each stack of four sheets was then clamped between boards and allowed to set up overnight. Any concerns I had about the cement adhering were unnecessary - the four sheets seem to be irreversibly welded together.



The pieces were then cut down to size with a straight edge and box cutter, and cut at the appropriate angle to contour to the support brace

I used the same cement to bind the sound insulation to the panel. I'll be installing the right side panel in the vehicle soon; the left side after I decide how to wire the antenna.

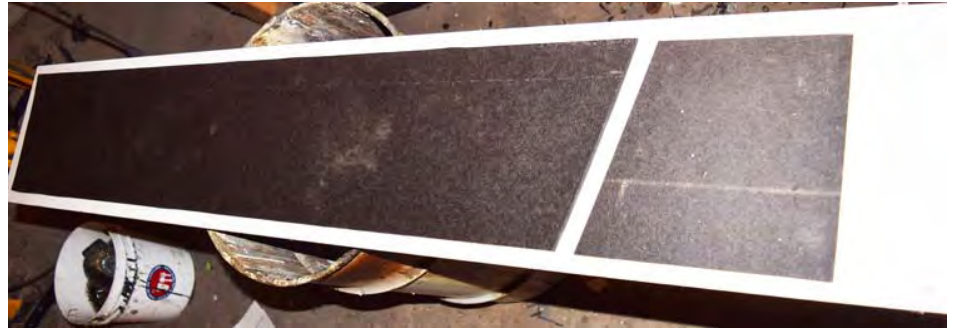

Installing these panels is a job I'm not looking forward to - a real tight fit, and it's a bear to reinstall the two lower bolts.

May 09, 2018

Headliner is up - looks great.



Clarks says it's a two-person job, but I didn't see the need. For each segment I first supported it in place with thin wooden strips, and with some heavy duty magnets that really locked it in place.

Notice the masking tape on the roof bows to protect them from the adhesive.

I then applied the adhesive on one side, allowed it flash for about 5-10 minutes and then rolled it back up. Then I did the same for the other side. This system worked fine.

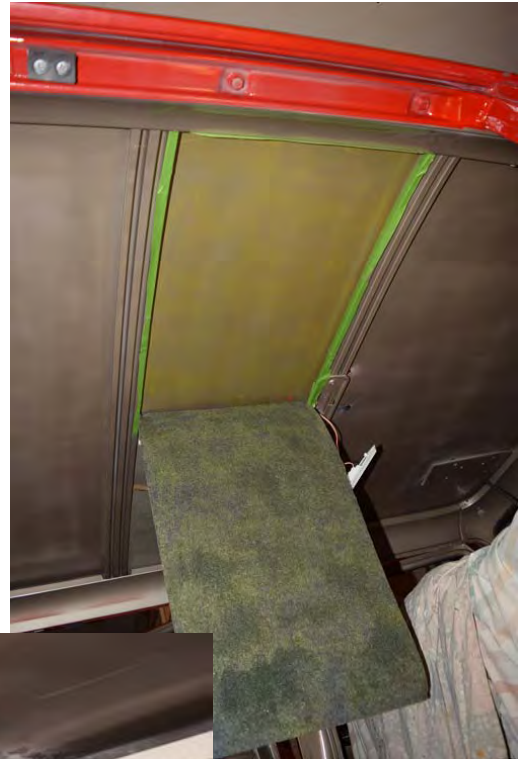

to



The cab roof was the most difficult section to apply since there is a metal plate welded in place that supports the siren.

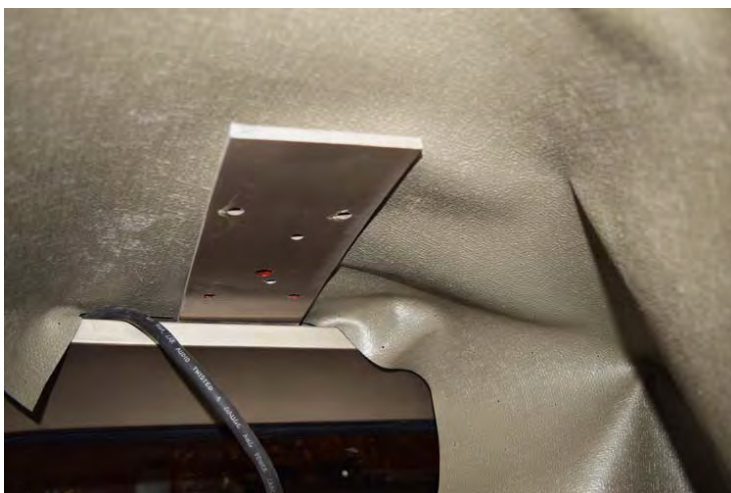

Fitting and cutting the headliner around the plate was tricky while trying not to have the adhesive bind prematurely,

but the end result worked out well.

I also inserted the roof spotlight. I'll be reporting on the electrical soon.



May 09, 2018

Since the siren and beacon light were gone when I acquired the Firebrier, I do not know exactly how they were attached. Thus, I feel at liberty to use crown nuts.



The spotlight was attached with sheet metal screws (which were standard hardware for the Unity lights), and I used these.

but I'm not thrilled with the appearance and may place small plastic caps over the ends.

May 14, 2018

Backend of the Firebrier is almost done.

I'm holding off on the license plate fixtures for a while yet (don't want to accidentally bang 'em in my tight garage), and the door bumpers need to await installation of the inner panels.



The bumper brackets had been stripped and repainted.

The two large brackets have rubber seals. Since these seals are found on the brackets of rear bumper but not the front, I assume they are intended to block air flow into the engine compartment. The seals on the Firebrier were pretty well obliterated, but Bob Marlow sent me photos of some seals that were in better condition, and the profile is shown in this diagram.

Unable to find a weatherstrip or seal that matched this design from any commercial supplier, I created a pretty good replacement by trimming FC side door window channel - the shape and dimensions matched well. The original seals were removed by carefully bending up the retainer, and this was reversed to reinstall the replacement.

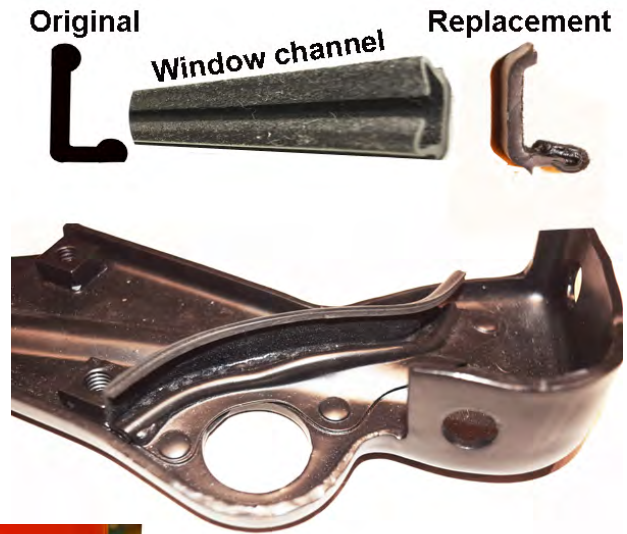

The emergency flashers on the back were manufactured by Dietz.



The originals couldn't be restored, but I was able to locate NOS replacements. However, the replacements were painted, so I had them chromed to match the originals.

The rear grille looks really nice.

As do the emblems. The original Berzal's emblem is priceless! And it polished up nicely; I thought I saw traces of red paint in the engraved lettering, so I added that. The other emblems are NOS replacements. I'm always really nervous installing (and uninstally) the emblems, fearing the metal will break; but all went well.



May 17, 2018

Little steps and big steps

First small stuff

Interior handles are installed

Thought this would be straight forward, by like usual it wasn't.



Can anyone tell apart these different window and door latch handles?

I can't, other than that the door handle on the far right is one of 4 new handles I had acquired a while back.

The differences are apparent on the back side - here's the door handles.



Only the GM handles have the set screw angled, making tightening much easier. 3707582 was the standard FC handle from 1961-64 (why one of these handles has a set screw that is almost centered is a mystery), and then 3848873 was substituted in 1965. It has a slightly more tapered handle. The repro handles are actually more substantial in their construction than the original GM handles. But after much soul-searching, I decided to pass on the brand new repros and use only original GM handles. On one hand, I really hate the center mounted set screws; but also the original handles cleaned up pretty nicely. And I suggest to others try cleaning the original; they may be good if the splines are intact and there's no significant pitting of the chrome.



This is a window crank handle before and after buffing it up with rubbing compound. I found I had enough GM handles that cleaned up equally well.



The big news is that after I got the handles on - and realized that the wiper motor was bad (see the other thread on wiper motor not turning off) so couldn't install the wipers - we took the Firebrier on it's first legal drive around the block a couple of times. Here it is:



Still much to be done - mirrors, interior work, wheel covers, wipers, etc. But it successfully hit the pavement for the first time since 1995. I think the shifter needs adjustment (I hope that's it and not the transmission); I was having a difficult time getting it into second, sometimes it went in smoothly sometimes gears

would grind - any suggestions would be appreciated. I actually feel the early style shifter in my 61 is easier to use than this late style.

But at any rate, we attracted as much attention as possible with the beacon and flashing lights on, and hitting the siren periodically.

The front lights are the original Turnflex lights rechromed, the rear lights are the Dietz lights that I posted about earlier. The lights run from a standard GM hazard flasher switch:

I bought one of the GM restoration units sold on ebay. Cost a bundle, but the 1963 unit was an exact match for the original in the Firebrier. The wiring was a bit of a rats-nest as got it, but I could see the way the wires coming out of the original flasher switch has been joined, and I found that there was only a single wire running to both of the rear flasher lights; Thus, based upon the evidence in the Firebrier, the lights were originally wired to flash in unison.

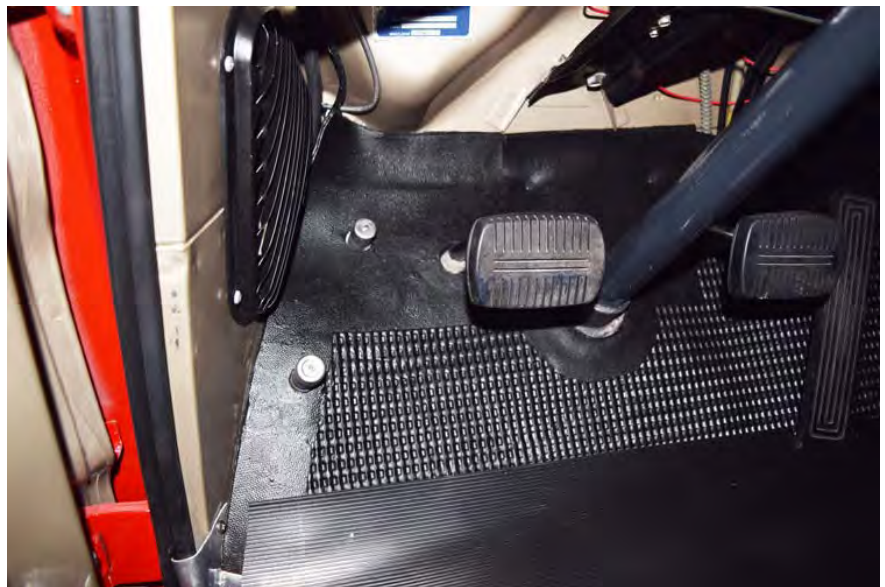

Speaking of controls, the siren runs from foot buttons, one on either side of the cab.

The beacon light is turned on from a switch mounted on the dash.

May 28, 2018

I've been mov'in along on the reassembly, not without occasional setbacks... the latest being the whitewalls:

I had noticed this discoloration of the whitewalls spreading from the rim, but thinking it was just dirt or a stain from the body shop. Nope, absolutely permanent;

turns out to be a manufacturing defect. Good news is the Coker Tire Company has agreed to replace them, but I have to pay up-front for the replacements - \$\$\$ - (which they refund when the defective ones are returned) and pay to have the defective tires removed and the new ones mounted and balanced. - all without damaging the paint on the wheels. PITA



The rear inner panels have been installed.



Getting these panels is never easy, and I find the best way is to angle them in from the bottom to minimize chances of scratching the floor paint. Installing the two screws that secure each panel from the underside is a particular annoyance; made only slightly easier by chasing the threads beforehand.



I've installed the jacking instruction sheet between the two NOS jack brackets. Does anyone know where exactly the positraction warning sticker should be placed. The assembly manual shows it directly above the jacking sticker, but that doesn't make sense. Fortunately I had a good supply of those "sombbrero" screws used secure everything back there; with soft brass brush and fine steel wool they all polished up nicely.



to

Here's the left side before installation of the cardboard corner piece. The antenna coax cable for the two-way radio is wired up to the bottom of the front seat (more about that later). A nice repro cardboard piece is available from Clarks. However, some work will be needed to make it look right.

The color of the repro panels was not a good match, so I painted them the interior fawn. I needed to do some trimming with a straight edge and exacto-knife to allow the panels to fit correctly.



Further forward, the load area mat was installed. I had near-perfect rubber support pieces - saved for years - that serve to fill the floor corrugations

and provide a flat surface for the mat



And here's the floor mat installed above it.

Finally, I get to actually use one of my repro floor mats in my own vehicle!!

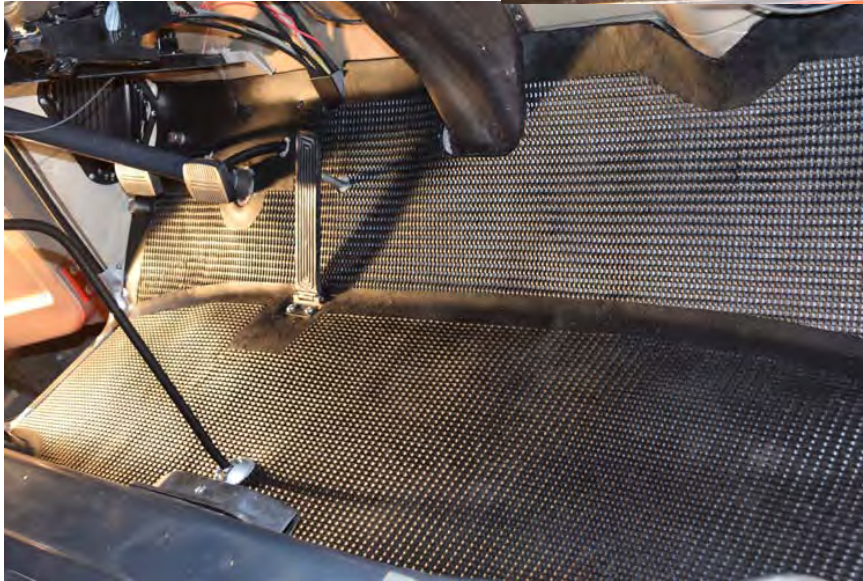

And another one up front.

Underneath is an original tarpaper layer (two pieces), and a polyester fiber layer above - no reproduction for the original jute is available.



And the front scuff plates are in place. The large upper ones are NOS the lower ones are restored used ones.

June 02, 2018 08:08PM
Really getting down to the nitty gritty.
The Motorola Motrac two-way radio is installed. Here's the head unit mounted under the dash.

The radio electronics have been fully restored by a local electronics wizard with much experience with these old units. He came out of retirement to do this one.

The microphone is temporarily attached to a bracket connected under the dash. There were numerous screw holes in the dash originally (all removed), but none that clearly would have been for the mike, and the most obvious location - to the left of the ash tray - had no screw holes at all. If I get more information as to where the microphone was originally mounted, I can move it later.

The head unit connects via a cable that runs under the front floor mat to the receiver/transmitter/power-supply unit located under the front seat.



Here I have the seat tilted up so I have working space. The unit just fits under the seat adjustment relay rod. The radio actually has three power input lines. The large red wire to this unit connects directly to the battery (at the starter). Separate power inputs to the head unit turn on the receiver and transmitter as needed. The transmitter is on the ignition switch circuit to avoid killing the battery.

A 102" antenna is installed. The coaxial cable follows the battery positive cable through the grommet in the front left corner of the engine compartment and continues to and comes up under the front seat. As I said the unit is fully functional, although I am not sure which FM wavelength it operates on. So far I have been unable to pick up any conversations, either from 2018 or the 1960s.



The above picture also shows that the outside rear view mirrors are mounted. !963 was the last year these larger West Coast Jr mirrors were a dealer installed option.

I've heard other people denigrate these mirrors, but I've always liked them - really ruggedly constructed . . .



. . . but difficult to install. If they need to be painted (as these were) be sure to pre-mount, bending the brackets as necessary beforehand.

Positioning the clamps with the black gaskets in place is a real pain, but here is another great new use of electrical shrink tubing.

1" diameter heat shrink tubing will collapse down to the perfect diameter to serve as the gasket. And you can tighten and loosen the clamps as needed and the tubing will slide with the clamp as its position is adjusted



Unfortunately, the rear doorway of the enclosed trailer I've ordered (scheduled to arrive next week) will not be wide enough to fit the van with the mirrors, so I've made arrangements to allow easy removal of the mirrors. Actually, the only real problem to doing so is the third support arm that mounts directly to the door. Loosening the nut risks losing the unusual shaped bolt that fits into the door jamb. My solution was to secure this bolt permanently in place.

I made a small sleeve that fills the excess space in the hole through which the bolt passes; with a little JB bond on the back side the bolt is locked in place exactly where needed.



The other accommodation for mirror removal is using a 1/32" self-adhesive rubber sheet as the gasket.

This way the gasket will also not be lost when the mirror is removed.



On the to-do list is making a couple of foam-lined boxes for storing the mirrors. to the perfect diameter to serve as the gasket. And you can tighten and loosen

June 11, 2018 06:11AM

I have mixed feelings of excitement and just being numb, but the Firebrier is essentially done. We've cruised around town a bit lately and it seems to drive well. I finally got the heater wired correctly, realizing after much fussing that that, of course, the bulb for the heater control only illuminates when the headlights are on - Duh!

I thought I'd first show a superb historical picture I recently received.



That is Emmett Vedder behind the wheel in 1963. Emmett was the "first driver" of the van for several years after it went into service. The picture was kindly provided by his son Emmett Vedder, Jr.

And this is Firebrier as found in Florida:



To help show off the restored Firebrier, I recruited a cute babe.



Jane helped periodically by holding parts when an extra hand was needed and applying bandages when a wounded hand needed repair.



The antenna will be cut down to 58". Those are GM restoration part reproductions of the original 1963 wheel covers. The replacement whitewalls arrived and are installed.





The M-3611 on the rear bumper is the vehicle identifier (M = miscellaneous vehicle type, 36 = the county identifier, 11 = 10,11,12,14 are vehicles at station 1).





I'm using a vintage wood tool box as a storage container. The top of the box fits nicely behind the seat.



The engine lid is unhinged (like the owner?), and I made a fancy wood brace to hold it open.

The engine before



and now



I finished and installed the side air baffles.



Left side doors open.



I've been acquiring various authentic fire scene equipment over the last two years, some of it, including the large resuscitator (hard to see in front of the right side doors) and the yellow fireman's hat are original to the Fire Company. A Smith Air pack, Indian Fire tank, axes and other gear are representative of typical gear that would have been carried. Note the base of the wood tool box that fits perfectly under the rear seat. There was a rear seat for the van, but normally it was only installed for parades and other non-fire scene functions. On the seat is a reproduction of the painting made of the van's original delivery to the Fire Company



Originally there were no seat belts, but I have installed original 1963 FC belts restored by Snake-Oyl (breathtakingly expensive!).



Another view

So other than a few assorted little tasks, the Firebrier is done. I'm really excited to be bringing it to Pittsburgh for the CORSA Convention (assuming the trailer I ordered finally arrives). And equally excited to be bringing it back to Saugerties NY for a large car show on July the 8th, where it will have a special display. While there, the Firebrier will also be returning to the Malden Fire Station, it's original home, and I hope to be posting pictures.

Date: September 23, 2020

The Firebrier has new hubcaps, which I believe now match the originals.

Here's how the Firebrier has been outfitted to-date:

Those are standard 1963 14" GM wheel covers.

That the Firebrier had wheel covers at all was somewhat surprising considering it was an utilitarian vehicle with standard trim and the "truck shipper" did not include RPO P01 (wheel covers) among its optional equipment. But the historical pictures clearly showed wheel covers;



Well maybe not "clearly". To my eye they looked like the standard 1963 14" GM wheel covers.

Which is what I purchased. I had also painted the

rims white (which was also unusual), since I could not see any evidence of a darker red band around the perimeter.



But Danny Davis studied more carefully one of the historical pictures, the one to the far right of Emmett Vedder stationed in the cab of the little fire truck he drove. Danny's more experienced eye picked out features that I would not have recognized – rather than a wheel cover, it was a wheel trim ring around a poverty hubcap. This Photoshopped close-up shows more clearly a trim ring with 8 concentric slots and the distinctive 4 ribbed design of the '63 Chevy car poverty hubcaps.

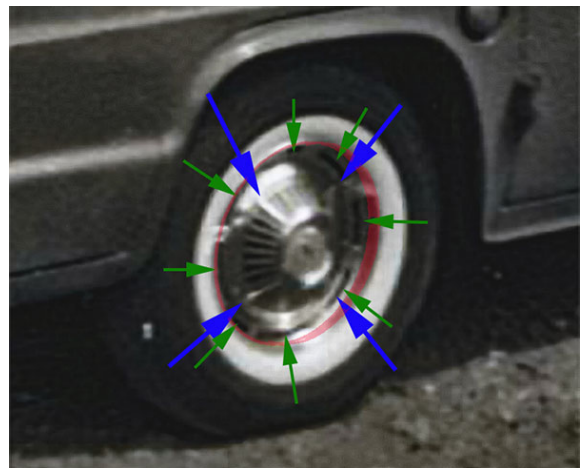

These I would not have recognized myself, so I thank Danny not only for making the ID, but also for generously providing a matching set of the trim rings!

It took a while to find excellent quality hubcaps that did not cause poverty – NOS or excellent quality caps were listing for around a grand – but I recently found a set more reasonably priced. The Photoshopped image also revealed a darker perimeter around the trim ring, which I now believe was the red wheel – at least this would agree with the stock color. So I've repainted the rims red and installed the new trim rings and hubcaps.



And here what they look like on the Firebrier:



I do feel the red rim looks much better.