

SECTION 11

HEATERS AND ACCESSORIES

CONTENTS OF THIS SECTION

| | <i>Page</i> |
|-------------------------------|-------------|
| Gasoline Heater | 11-1 |
| Direct Air Heater | 11-1 |
| Air Conditioning System | 11-3 |

GASOLINE HEATER

500, 700 AND 900 SERIES

Service information and procedures outlined in the 1961 Corvair Shop Manual are to be carried over for use with the 1962-63 vehicle with no change except for two corrections necessary to Fig. 11-21. Items No. 12 (Spark Plug Washer) and No. 15 (Spark Plug Sleeve) are not used in any 1961 through 1963 gasoline heater. Keep this fact in mind when performing disassembly and assembly procedures.

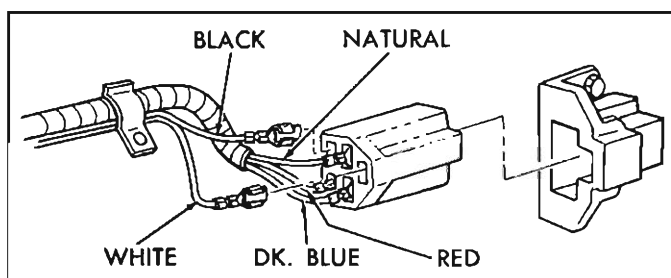

Fig. 11-1—Multiple Connector

Figure 11-33 in the 1961 Corvair Shop Manual shows incorrect wiring into the 5-way multiple connector. Correct wiring is shown above in Fig. 11-1.

1200 SERIES

Only one revision is necessary on the Corvair 95 gasoline heater information and this is a correction which applies to the 1961 model as well as to 1962-63.

DIRECT AIR HEATER

The 1962-63 Corvair Direct Air Heater remains basically the same as covered in the 1961 Corvair Shop Manual. Component location and service procedures will not change except for the following:

500, 700 AND 900 SERIES

- Rear seat heat outlets will have a manually operated shut-off door for 1962. Figure 11-2 illustrates the rear seat heat shut-off doors.

1200 SERIES

- Addition of the manual shut-off door over the rear seat heat outlets (fig. 11-2), plus improved heat duct components constitute the only Corvair 95 Direct Air Heater change for 1962.

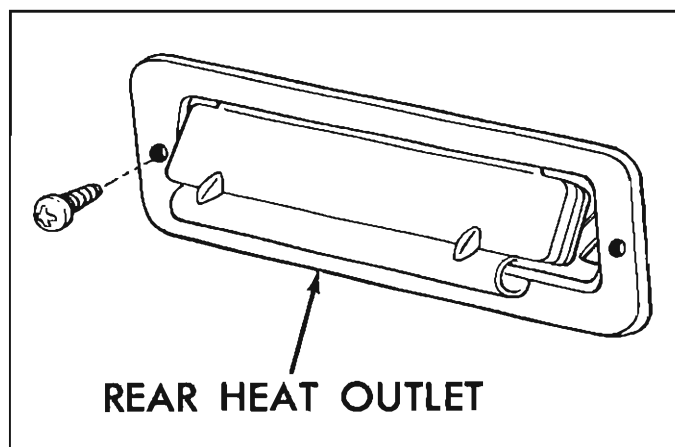

Fig. 11-2—Rear Seat Heat Outlet Door

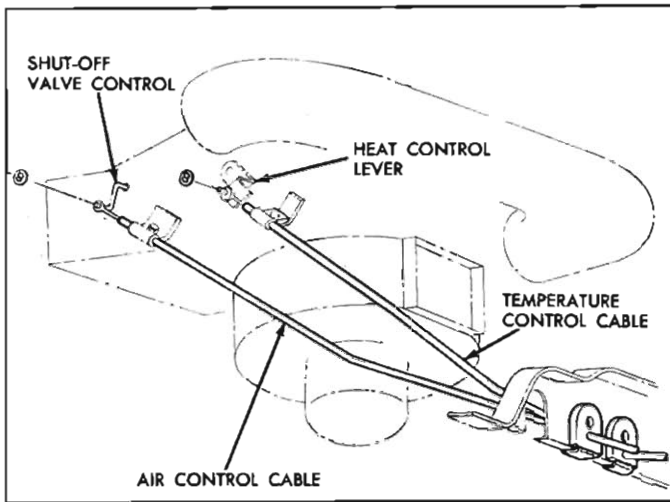

Fig. 11-3—Control Cable Adjustment

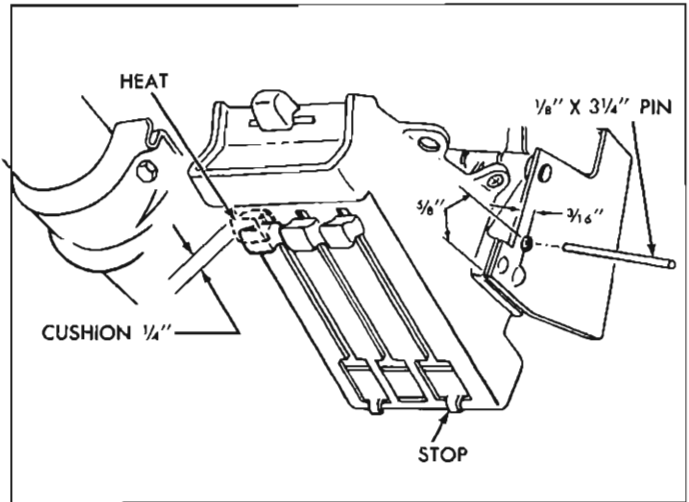

Fig. 11-4—Control Assembly

Heater Housing (500, 700 and 900 Series)

Control Cable Adjustment

1. If air leakage is present with the HEAT, AIR and DEFROSTER levers closed, disconnect the bowden cables from the diverter doors and manually close the doors.
2. Start the engine and (with FAN control lever OFF) feel for air leakage at the passenger compartment heater outlets.
3. If no leakage is evident, the problem is with improper bowden cable adjustment. Adjust as follows:

1962

- a. Adjust the cables until a "cushion" is felt at the end of the travel in the closed position.

NOTE: Properly adjusted, the cable sheath should be securely clamped with the metal caps extending beyond the clamps at the heater and, where required, at the control to hold the knob 1/4" from the top of the control assembly track when the control knobs are pulled up as far as the doors in the heater housing will permit.

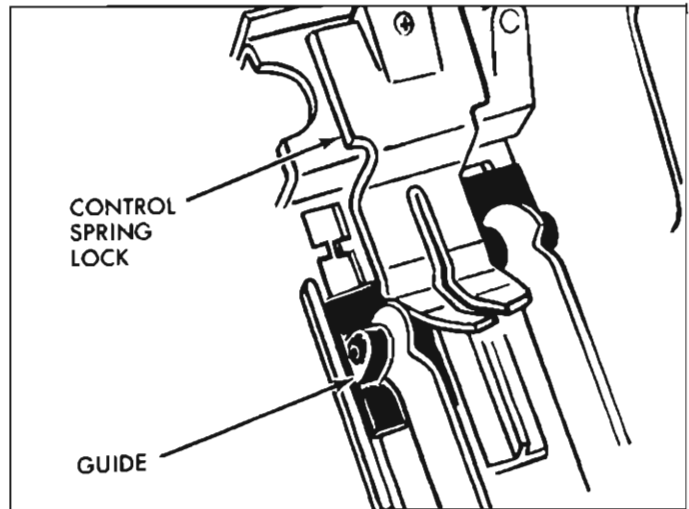

Fig. 11-5—Heater Control Spring Lock

door lever, apply a 5 to 10 lb. pull on the cable sheath. Then tighten the cable clamp.

- c. Adjust the defroster cable in the same manner except that the adjustment is made at the central assembly rather than at the door lever.
4. If leakage is still evident with cables disconnected and doors closed manually, it must be assumed that the doors are bent or seals are defective and replacement of the heater housing is necessary.

1963

- a. Pull the HEAT and AIR knobs into the fully up position and insert the pin (fig. 11-4) in place in the control assembly.
- b. Lift the vehicle and, with the cable clamps loosened and the stress wire pigtail on the proper

1963 Control Assembly Spring Lock

A spring lock arrangement in the control assembly (fig. 11-5) assures positive diverter door closure. When closing the diverter doors be sure that the control levers are pulled fully up past the slight (cushion) or resistance to insure positive closing.

AIR CONDITIONING SYSTEM

INDEX

| | <i>Page</i> | | <i>Page</i> |
|--|-------------|---|-------------|
| General Description..... | 11- 4 | Removal..... | 11-25 |
| General Information..... | 11- 5 | Installation..... | 11-25 |
| Precautions in Handling Freon-12..... | 11- 5 | Blower Switch Replacement..... | 11-25 |
| Maintaining Stability in the Refrigeration System..... | 11- 6 | Compressor..... | 11-25 |
| Pressure Temperature Relationship of Freon-12..... | 11- 6 | Removal..... | 11-25 |
| Gauge Set..... | 11- 7 | Installation..... | 11-26 |
| Leak Testing the System..... | 11- 7 | Minor Service Operations | |
| Vacuum Pump..... | 11- 8 | Hub and Drive Plate..... | 11-27 |
| Availability of Freon-12..... | 11- 9 | Removal..... | 11-27 |
| Compressor Oil..... | 11- 9 | Inspection..... | 11-27 |
| Compressor Serial Number..... | 11- 9 | Installation..... | 11-27 |
| Inspection and Periodic Service..... | 11-10 | Pulley and Bearing Assembly..... | 11-28 |
| Pre-delivery Inspection..... | 11-10 | Removal..... | 11-28 |
| 1000 Mile Inspection..... | 11-10 | Inspection..... | 11-28 |
| Periodic Service..... | 11-10 | Bearing Replacement..... | 11-29 |
| Maintenance and Adjustments..... | 11-10 | Installation..... | 11-29 |
| Performance Test..... | 11-10 | Coil Housing Assembly..... | 11-29 |
| Diagnosis..... | 11-11 | Removal..... | 11-29 |
| Diagnosis Summary..... | 11-13 | Inspection..... | 11-29 |
| Initial Checks and Adjustments..... | 11-13 | Installation..... | 11-29 |
| Thermostatic Switch..... | 11-13 | Major Service Operations | |
| Expansion Valve..... | 11-15 | Shaft Seal Assembly..... | 11-31 |
| System Service Operations..... | 11-15 | Removal..... | 11-31 |
| System Capacities..... | 11-15 | Inspection..... | 11-32 |
| Precautions in Handling Refrigerant Lines... | 11-15 | Installation..... | 11-32 |
| Refrigerant Line Connections..... | 11-15 | Pressure Relief Valve..... | 11-32 |
| "O" Ring Connections..... | 11-15 | Compressor Rear Head and Internal Mechanism..... | 11-32 |
| Hose Clamp Connections..... | 11-16 | Rear Head, Oil Pump and Valve Assemblies..... | 11-32 |
| Freon Hose Failure..... | 11-16 | Removal..... | 11-32 |
| Conditioning System for Replacement of Component Parts..... | 11-16 | Installation..... | 11-33 |
| Installing Gauge Set to Check System Operation..... | 11-16 | Major Interior Mechanism | |
| Purging the System..... | 11-17 | Removal from Shell..... | 11-33 |
| Evacuating and Charging the System..... | 11-17 | Disassembly..... | 11-34 |
| Vacuum Pump Method..... | 11-17 | Gauging Procedures..... | 11-35 |
| Freon Charging Station Method..... | 11-20 | Assembly..... | 11-37 |
| Checking and Adding Oil..... | 11-21 | Installation into Shell..... | 11-38 |
| Air or Excessive Refrigerant in the System... | 11-22 | Leak Testing the Compressor..... | 11-39 |
| Component Parts Service Operations..... | 11-22 | Compressor Belt Tension Adjustment... | 11-39 |
| Evaporator..... | 11-22 | Condenser..... | 11-39 |
| Removal from Vehicle..... | 11-22 | Replacement..... | 11-39 |
| Core Replacement..... | 11-23 | Engine Access Procedure..... | 11-40 |
| Installation in Vehicle..... | 11-24 | Receiver-Dehydrator..... | 11-40 |
| Expansion Valve..... | 11-24 | Replacement..... | 11-40 |
| Replacement..... | 11-24 | Collision Procedure..... | 11-40 |
| Thermostatic Switch or Blower Motor..... | 11-24 | Flushing the System..... | 11-41 |
| Replacement..... | 11-24 | Fast Idle Adjustment..... | 11-41 |
| Control Panel Assembly..... | 11-25 | Operating Instructions..... | 11-41 |
| | | Wiring Diagrams..... | 11-42 |
| | | Special Tools..... | 11-43 |

GENERAL DESCRIPTION

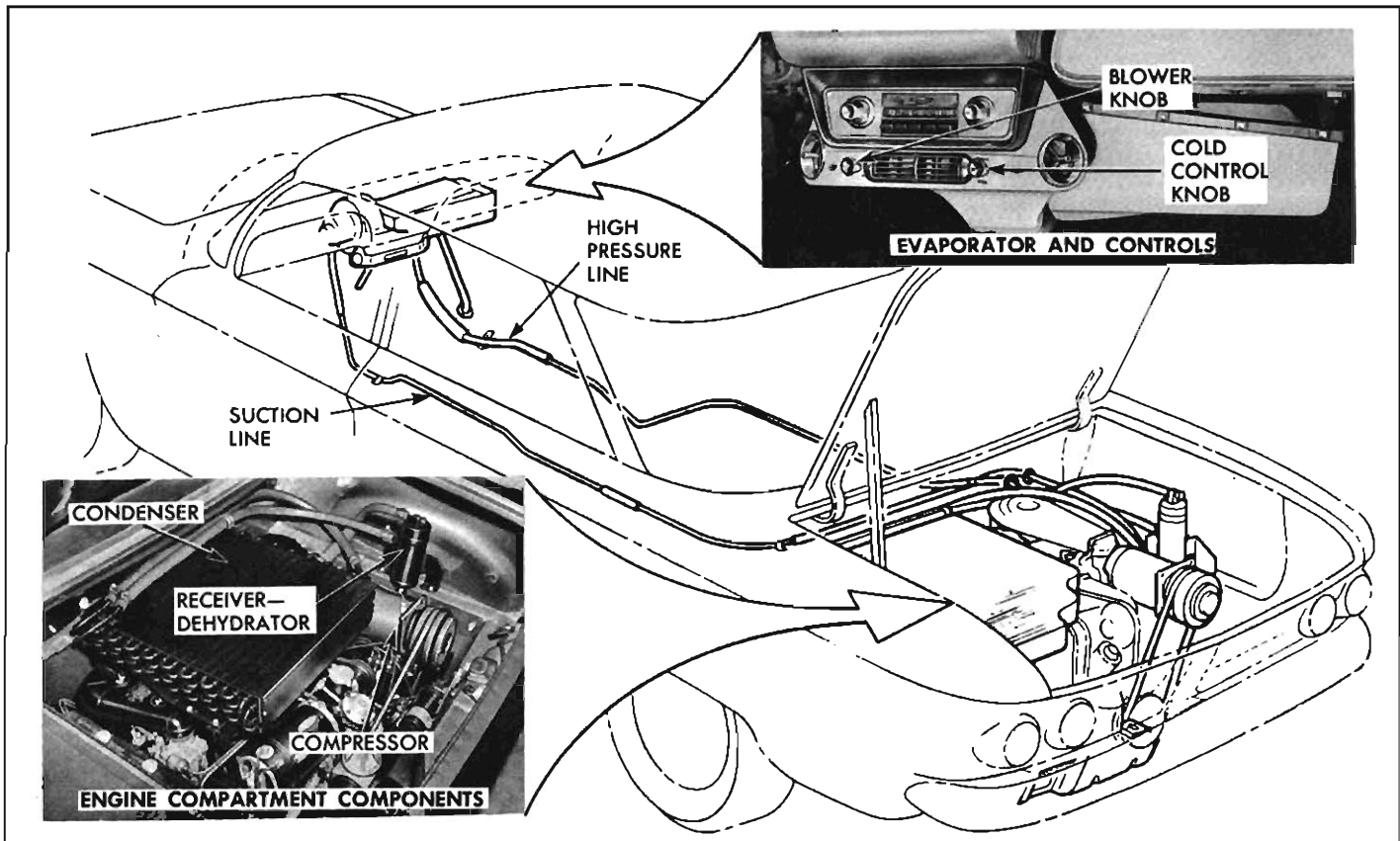

Fig. 11-6—Corvair Air Conditioning System

The 1962-63 Corvair Air Conditioning System is a 100% recirculated air cooling system. The evaporator, blower and temperature control (thermostatic switch) are mounted beneath the dash in the passenger compartment and are connected by means of refrigerant hoses and tubing and electrical wiring to the remainder of the system which is located in the engine compartment. Temperature control is achieved through the use of the thermostatic switch which controls the operation of the compressor cycling clutch. The compressor, painted green to identify it as a reverse rotation model and therefore not interchangeable with compressors used on other 1962-63 Chevrolet vehicles, is a completely new six-cylinder re-expansion type. It is lighter and quieter than the compressor used in the 1961 Corvair air conditioning system and is completely field serviceable. The condenser is mounted above the engine and is shrouded so that all air entering the engine must first pass through the condenser coil. Mounted on the right rear quarter inner panel is the receiver-dehydrator with its sight glass. A selenium rectifier (fig. 11-7) acts in the electrical circuit as a night blower cutback switch. When the headlights are turned on, the air conditioning blower will be allowed to run no faster than MEDIUM speed. The control and

air distributor assembly mounts beneath the radio. The blower outlet flange in the evaporator assembly fits into the rear of the assembly. Refrigerant lines make use of hose clamp connections.

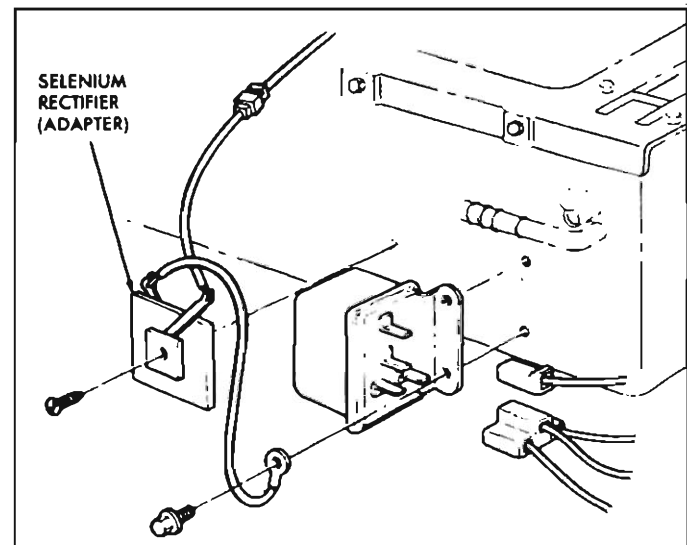

Fig. 11-7—Selenium Rectifier

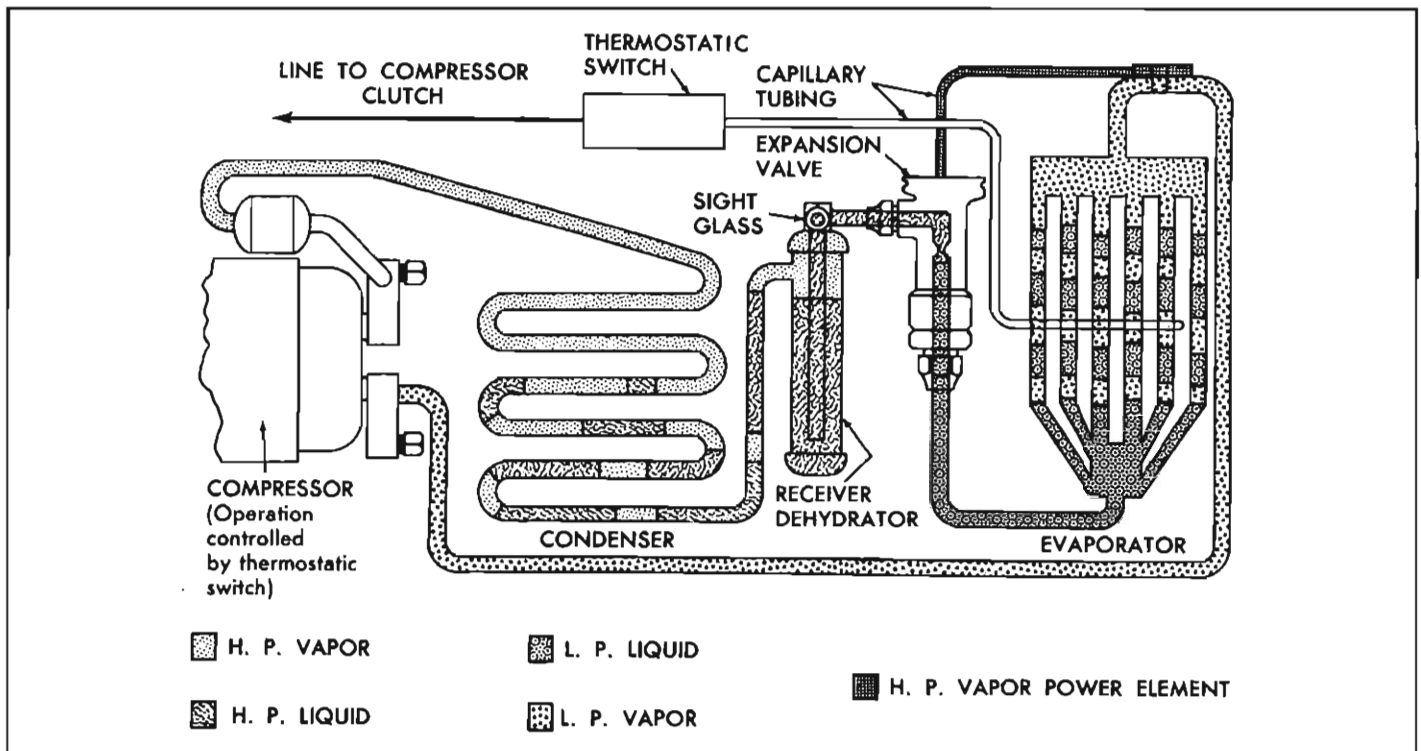

Fig. 11-8—Cycle of Operation—Corvair Air Conditioning

Two 3AG-AGC 15 ampere fuses, located in in-line connectors mounted behind the instrument panel lower flange and to the left of the radio cover protect:

1. The compressor clutch and low and medium blower speed circuits.
2. The high blower speed circuit.

GENERAL INFORMATION

In any vocation or trade, there are established procedures and practices that have been developed after many years of experience. In addition, occupational hazards may be present that require the observation of certain precautions or use of special tools and equipment. Observing the procedures, practices and precautions of servicing refrigeration equipment will greatly reduce the possibilities of damage to the customers' equipment as well as virtually eliminate the element of hazard to the serviceman.

PRECAUTIONS IN HANDLING FREON-12

Freon-12 is a transparent and colorless refrigerant in both the gaseous and liquid state. It has a boiling point of 21.7°F below zero and, therefore, at all normal temperatures and pressures it will be a vapor. The vapor is heavier than air and is nonflammable, non-explosive, nonpoisonous (except when in contact with an open flame) and noncorrosive (except when in contact with water). The following precautions in handling Freon-12 should be observed at all times.

- All refrigerant drums are shipped with a heavy metal screw cap. The purpose of the cap is to pro-

tect the valve and safety plug from damage. It is good practice to replace the cap after each use of the drum.

- If it is ever necessary to transport or carry a drum or can of refrigerant in a car, keep it in the luggage compartment. Refrigerant should not be exposed to the radiant heat from the sun for the resulting increase in pressure may cause the safety plug to release or the drum or can to burst.
- Drums or disposable cans should never be subjected to high temperature when adding refrigerant to the system. In most instances, heating the drum or can is required to raise the pressure in the Freon container higher than the pressure in the system during the operation. It would be unwise to place the drum on a gas stove, radiator or use a blow torch while preparing for the charging operation, for a serious accident can result. Don't depend on the safety plug—many drums have burst when the safety plug failed. Remember, pressure can be a powerful force. A bucket of warm water, not over 125°F, or warm wet rags around the Freon container is all the heat that is required.

- Do not weld or steam clean on or near the system. Welding or steam cleaning can result in a dangerous pressure buildup in the system.
- When filling a small drum from a large one, never fill the drum completely. Space should always be allowed above the liquid for expansion. If the drum were completely full and the temperature was increased, hydraulic pressure with its tremendous force would result.
- Discharging large quantities of Freon-12 into a room can usually be done safely as the vapor would produce no ill effects; however, in the event of an accidental rapid discharge of the system, it is recommended that inhalation of large quantities of Freon be avoided. This caution is very important if the area contains a flame producing device such as a gas heater. While Freon-12 normally is nonpoisonous, heavy concentrations of it in contact with a live flame will produce a toxic gas. The same gas will also attack all bright metal surfaces.
- Protection of the eyes is of vital importance! When working around a refrigerating system, an accident may cause liquid refrigerant to hit the face. If the eyes are protected with goggles or glasses, no serious damage can result. *Just remember, any Freon-12 liquid that you can touch or that touches you is at least 21.7° F. below zero.* The eyeballs can't take much of this temperature. If Freon-12 liquid should strike the eyeballs, here is what to do:

1. Keep calm.
2. Do not rub the eyes! Splash the affected area with quantities of cold water to gradually get the temperature above the freezing point. The use of mineral, cod liver or an antiseptic oil is important in providing a protective film to reduce the possibility of infection.
3. As soon as possible, call or consult an eye specialist for immediate and future treatment.

REMEMBER—"An ounce of prevention is worth a pound of cure."

MAINTAINING CHEMICAL STABILITY IN THE REFRIGERATION SYSTEM

The metal internal parts of the Chevrolet refrigeration system and the refrigerant and oil contained in the system are designed to remain in a state of chemical stability as long as pure Freon-12 plus refrigeration oil is used in the system.

However, when abnormal amounts of foreign materials, such as dirt, air or moisture are allowed to enter the system, the chemical stability may be upset. When accelerated by heat, these contaminants may form acids and sludge and eventually cause the breakdown of components within the system. In addition, contaminants may affect the temperature-pressure relationship of Freon, resulting in improper operating temperature and pressures and decreased efficiency of the system.

The following general practices should be observed to insure chemical stability in the system.

- Whenever it becomes necessary to disconnect a refrigerant or gauge line, it should be immediately capped. Capping the tubing will also prevent dirt and foreign matter from entering.
- Tools should be kept clean and dry. This also includes the gauge set and replacement parts.
- When adding oil, the container should be exceptionally clean and dry due to the fact that the refrigeration oil in the container is as moisture-free as it is possible to make it. Therefore, it will quickly absorb any moisture with which it comes in contact. For this same reason the oil container should not be opened until ready for use and then it should be capped immediately after use.
- When it is necessary to open a system, have everything you will need ready and handy so that as little time as possible will be required to perform the operation. Don't leave the system open any longer than is necessary.
- Finally, after the operation has been completed and the system sealed again, air and moisture should be evacuated from the system before recharging.

PRESSURE—TEMPERATURE RELATIONSHIP OF FREON-12 REFRIGERANT

| °F. | # Pressure | °F. | # Pressure |
|-----|------------|-----|------------|
| -40 | 11.0* | 50 | 46.7 |
| -35 | 8.3* | 55 | 52.0 |
| -30 | 5.5* | 60 | 57.7 |
| -25 | 2.3* | 65 | 63.7 |
| -20 | 0.6 | 70 | 70.1 |
| -15 | 2.4 | 75 | 76.9 |
| -10 | 4.5 | 80 | 84.1 |
| - 5 | 6.8 | 85 | 91.7 |
| - 0 | 9.2 | 90 | 99.6 |
| 5 | 11.8 | 95 | 108.1 |
| 10 | 14.7 | 100 | 116.9 |
| 15 | 17.7 | 105 | 126.2 |
| 20 | 21.1 | 110 | 136.0 |
| 25 | 24.6 | 115 | 146.5 |
| 30 | 28.5 | 120 | 157.1 |
| 32 | 30.1 | 125 | 167.5 |
| 35 | 32.6 | 130 | 179.0 |
| 40 | 37.0 | 140 | 204.5 |
| 45 | 41.7 | 150 | 232.0 |

*Inches of Vacuum

The chart above shows us that every time we raise or lower the temperature of a quantity of Freon-12 liquid, we also raise or lower the pressure on it. Unfortunately this is not done in the same ratio. For example at 70° the chart shows that the pressure is also 70 pounds. But this is true only at 70°. However, *if we know the temperature of the liquid in the cooling coil*

or the receiver, we can refer to a pressure-temperature table and determine what the pressure should be.

The figures can also be used in a reverse manner. If we know what the pressure is at any point in the system we can refer to the pressure-temperature table and determine what the temperature should be.

GAUGE SET

The gauge set (fig. 11-9) is used when purging, evacuating, charging or diagnosing trouble in the system. The gauge at the right is known as the low pressure gauge. The face is graduated into pounds of pressure from 0 to 150 and, in the opposite direction, in inches of vacuum from 0 to 30 inches. This is the gauge that should always be used in checking pressures on the low pressure side of the system. When all parts of the system are functioning properly the refrigerant pressure on the low pressure side never falls below 0 pounds pressure. However, several abnormal conditions can occur that will cause the low pressure to fall into a partial vacuum. Therefore, a low pressure gauge is required.

The gauge at the left is graduated from 0 to 300 pounds pressure. This is known as the high pressure gauge and, of course, is used for checking pressures on the high pressure side of the system.

The connection at the right is for attaching the low pressure gauge line and the one at the left the high pressure gauge line. The center connector is common to both and is for the purpose of attaching a line for adding refrigerant, discharging refrigerant, evacuating the system and other uses. When not required, this line or connection should be capped.

NOTE: Gauge fitting connections should be installed hand tight only and the connections leak tested before proceeding.

The hand shutoff valves on the gauge manifold do not control the opening or closing off of pressure to the gauges. They merely close each opening to the

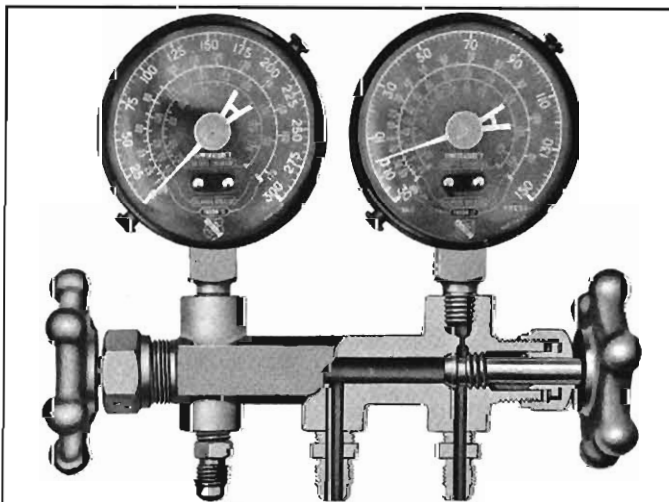

Fig. 11-9—Gauge Set

center connector and to each other. During most diagnosing and service operations, the valves must be closed. The only occasion for opening both at the same time would be to bypass refrigerant vapor from the high pressure to the low pressure side of the system, or in evacuating both sides of the system.

A temperature scale for Freon-12 (yellow band) has been provided on the gauges. The temperatures on this scale are in correct relationship to the pressures on the outside (white) pressure band, providing a quick and convenient pressure-temperature relationship reference for Freon-12.

LEAK TESTING THE SYSTEM

Testing the system for refrigerant leaks is accomplished with a leak detector, Tool J-6084, a propane gas-burning torch (fig. 11-10) which is described below under "Leak Detector."

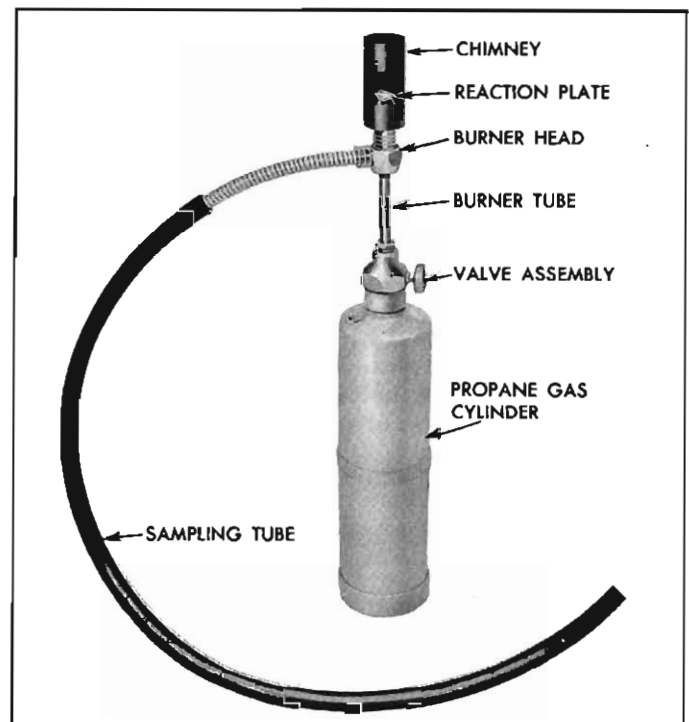

Fig. 11-10—Leak Detector

Whenever a leak is suspected in the system or a service operation performed which results in disturbing lines or connections, it is advisable to test for leaks. Common sense should be the governing factor in performing any leak test, since the necessity and extent of any such test will, in general, depend upon the nature of the complaint and the type of service performed on the system. It is better to test and be sure, if in doubt, than to risk the possibility of having to do the job over again.

Leak Detector

Tool J-6084 (fig. 11-10) is a propane gas-burning torch which is used to locate a leak in any part of the

Freon system. Freon gas drawn into the sampling tube attached to the torch will cause the torch flame to change color in proportion to the size of the leak. Propane gas fuel cylinders used with the torch are readily available commercially throughout the country.

CAUTION: Do not use lighted detector in any place where combustible or explosive gases, dusts or vapors may be present.

Assembling Detector

1. Remove dust cap from cylinder.
2. Thread detector unit onto top of fuel cylinder. Turn to right (clockwise) until the unit is HAND TIGHT. Do not use a wrench to tighten.
3. Check valve knob to be sure it is in fully closed position.
4. Assemble sampling hose to detector unit.

Operating Detector

1. Open control valve only until a low hiss of gas is heard, then light gas at opening in chimney.
2. Adjust flame until desired volume is obtained. This is most satisfactory when blue flame is approximately 3/8" above reaction plate. The reaction plate will quickly heat to a cherry red.
3. Explore for leaks by moving the end of the sampling hose around possible leak points in system. Do not pinch or kink the hose.

NOTE: Since Freon-12 is heavier than air, it is good practice to place open end of sampling tube immediately below point being tested, particularly in cases of small leaks.

CAUTION: Do not breathe the fumes that are produced by the burning of Freon gas in the detector flame, since such fumes can be toxic in large concentrations of Freon.

4. Watch for color changes. The color of the flame which passes through the reaction plate will change to yellow when sampling hose draws in very small leaks of Freon-12. Large leaks will be indicated by a change in color to a vivid purplish-blue. When the sampling hose passes the leak, the flame will clear to an almost colorless pale-blue again.

NOTE: If the flame remains yellow when unit is removed from leak, insufficient air is being drawn in or the reaction plate is dirty. See "Servicing the Leak Detector" below.

Servicing the Leak Detector

Insufficient Air

Insufficient air may be caused by:

1. Obstructed or partially collapsed sampling tube.
2. Dirt or foreign substance in burner tube.
3. Dirty or partially clogged orifice.

Blowing air through the sampling hose and back

through the detector will usually clear dirt or foreign matter.

Dirty Reaction Plate

If a continuous yellow flame is caused by a dirty reaction plate, allow the flame to burn for several minutes. This will usually burn the plate clean. If an oxide film appears on the reaction plate from continued use, it will reduce the sensitivity of the detector. This may be remedied by removing the plate, which is attached to the chimney with a single screw, and scraping the surface gently with a knife.

Dirty or Partially Clogged Orifice

NOTE: Never attempt to clean orifice by passing anything through the hole.

1. Unscrew burner head assembly from burner tube connecting head to valve assembly. Use a wrench if necessary.
2. Remove orifice from tube.
3. Reverse orifice and screw burner head onto burner tube hand tight.
4. With unit connected to propane cylinder, open valve quickly, admitting several short blasts.
5. Unscrew burned head, insert orifice into burned tube in normal position and screw burned head onto burner tube. Tighten with a wrench to form a gas-tight joint.

VACUUM PUMP

A vacuum pump should be used for evacuating air and moisture from the air conditioning system.

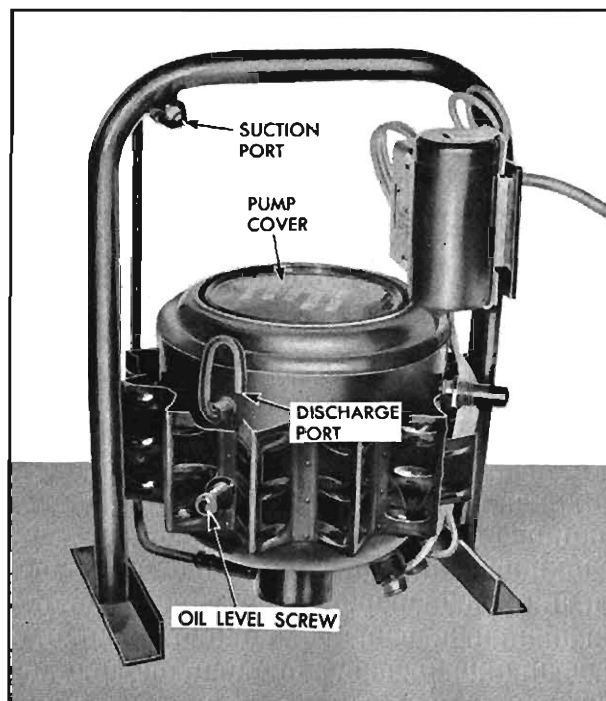

Fig. 11-11—Vacuum Pump

Vacuum pump, Tool J-5428, (fig. 11-11) is available for this purpose and its use is described under "Service Operations." The following precautions should be observed relative to the operation and maintenance of this pump.

- Install Tool J-5462-1 to vacuum pump to prevent pressure from entering pump (see fig. 11-20).
- Make sure dust cap on discharge outlet of vacuum pump is removed before operating.
- Check oil level frequently. Oil level should be up to the oil level screw on the side of the vacuum pump (fig. 11-11). Do not maintain fluid above this level as the pump will not operate properly.
- When adding oil, use only Frigidaire 150 viscosity oil. Carefully pry off top cover of pump and add oil as shown in Figure 11-12 to bring to proper level.

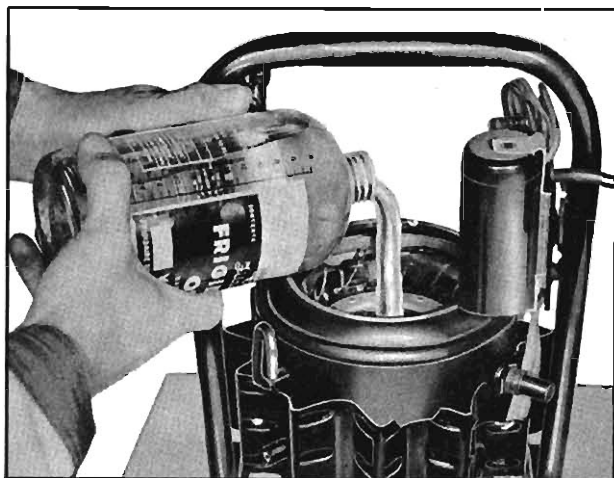

Fig. 11-12—Adding Oil to Vacuum Pump

- Change oil periodically. Remove compressor top and lay on side, holding rotor in place while draining. Rotor and eccentric can be replaced by rotating slowly to align eccentric and then lower gently into place.
- Cap suction and discharge ports when not in use.
- Do not use the vacuum pump as an air compressor.
- If pump does not start, check the capacitor and relay. Also, the top may be removed and the rotor turned by hand to relieve a temporary stuck condition.

AVAILABILITY OF FREON-12

Freon-12 is available through Parts Stock in 25 lb. drums and in 15 oz. disposable cans. Valves are available for the disposable cans, which can be used as individual cans or as a group of three cans connected in series (fig. 11-13).



Fig. 11-13—Freon-12 Disposable Cans and Valves

Tool J-6272 is used with the three cans connected in series. The use of the three-can fixture makes it possible to charge the system with a known quantity of refrigerant (45 oz.) without the use of weighing equipment necessary with the larger drum. The single can valve J-6271 can be used for completing the charge and for miscellaneous operations such as flushing. The valves are installed by piercing the top seal of the cans.

COMPRESSOR OIL

Special refrigeration lubricant should be used in the system. It is available in 1 quart graduated bottles through Parts Stock. This oil is as free from moisture and contaminants as it is possible to attain by human processes. This condition should be preserved by immediately capping the bottle when not in use.

See "Air Conditioning System Capacities" for the total system oil capacity.

Due to the porosity of the refrigerant hoses and connections, the system refrigerant level will show a definite drop after a period of time. Since the compressor oil is carried throughout the entire system mixed with the refrigerant, a low refrigerant level will cause a dangerous lack of lubrication. Therefore, the refrigerant charge in the system has a definite tie-in with the amount of oil found in the compressor and an insufficient charge may eventually lead to an oil buildup in the evaporator.

COMPRESSOR SERIAL NUMBER

The compressor serial number is located on the serial number plate on top of the compressor. The serial number consists of a series of numbers and letters (Example: 10-CC-001). This serial number should be referenced on all forms and correspondence related to the servicing of this part.

INSPECTION AND PERIODIC SERVICE

PREDELIVERY INSPECTION

1. Check the belt for proper tension.
2. With controls positioned for operation of the system, operate the unit for ten minutes at approximately 1500 rpm. Observe the clutch pulley bolt to see that the compressor is operating at the same speed as the clutch pulley. Any speed variation indicates clutch slippage.
3. Check the sight glass to see that the unit has a sufficient Freon-12 charge. Bubbles in the flow indicate a low charge. No liquid visible indicates no charge.
4. Leak test the complete system.
5. If there is evidence of an oil leak, check the compressor to see that the oil charge is satisfactory.
6. Check the system controls for proper operation.

1000 MILE INSPECTION

1. Check unit for any indication of a refrigerant leak. Tighten all hose clamp connections.
2. If there is an indication of an oil leak, check the compressor for proper oil charge.

3. Check sight glass for proper charge of Freon-12 (See Step 3 in Predelivery Check).
4. Tighten the compressor brace and support bolts and check the belt tension.

PERIODIC SERVICE

- Inspect condenser core regularly to be sure that it is not plugged with leaves or other foreign material.
- Check evaporator drain tubes regularly for dirt or restrictions.
- At least once a year, check the system for proper refrigerant charge and the flexible hoses for brittleness, wear, or leaks.
- Every 6000 miles check sight glass for low Freon level.
- Check belt tension regularly.
- Every week—during winter months or other periods when the system is not being operated regularly—run the system, set for maximum cooling, for 10 or 15 minutes to insure proper lubrication of seals and moving parts.

MAINTENANCE AND ADJUSTMENTS

PERFORMANCE TEST

This test may be conducted to determine if the system is performing in a satisfactory manner and should be used as a guide by the serviceman in diagnosing trouble within the system. The following fixed conditions must be adhered to in order to make it possible to compare the performance of the system being tested with the standard below:

1. Doors and windows closed.
2. Engine compartment lid up.
3. Large fan at the left side of vehicle just above rear fender level so that during tests fan air stream flows across top of condenser toward the right side of the vehicle.
4. Vehicle in NEUTRAL with engine running at 1500 rpm.
5. Air Conditioning controls set for—
 - a. Maximum cooling.
 - b. High blower speed.
6. Heater off.
7. Gauge set installed.

8. System settled out (run-in approximately 10 minutes).
9. A thermometer placed in the right hand diffuser outlet.

The following Performance Data define normal operation of the system under the above conditions. Relative humidity does not appear in the tables because after running the prescribed length of time on recirculated air and maximum cooling, the relative humidity of the air passing over the evaporator core will remain at approximately 35% to 40% regardless of the ambient temperature or humidity.

| Grille Air Temperature | 70° | 80° | 90° | 100° | 110° | 120° |
|------------------------------------|---------|---------|---------|---------|---------|---------|
| Engine RPM | 1500 | | | | | |
| Compressor Head Pressure* | 140-150 | 160-170 | 180-190 | 225-235 | 260-270 | 300-310 |
| Compressor Suction Pressure* | 13.5 | 13.5 | 15.5 | 17 | 17 | 17 |
| Discharge Air Temp. at R/H Outlet* | 37-42 | 38-43 | 38-43 | 38-43 | 40 | 47 |

*When compressor clutch disengages.

DIAGNOSIS

Whenever trouble develops in the refrigeration system, the diagnosis procedure listed below for the particular condition encountered, will assist in locating the source of trouble. Unless otherwise stated, checks and diagnosis procedures apply to both All Weather and Cool Pack Systems.

| Symptoms and Probable Cause | Diagnosis Procedures |
|--|---|
| Drafts | |
| <ul style="list-style-type: none"> a. Poor air distribution. b. Car temperature too low. | <ul style="list-style-type: none"> a. Readjust air outlets. b. Check thermostatic switch. Check control panel linkage. |
| Shortage of Air Supply at Outlets | |
| <ul style="list-style-type: none"> a. Car temperature up. b. Low fan speed. | <ul style="list-style-type: none"> a. Check fan speeds. Check cooling coil for air passage. b. Check voltage at fan motor. Check motor bearings. Check direction of motor rotation. |
| Air Noise | |
| <ul style="list-style-type: none"> a. Sharp obstruction in air stream. b. Obstruction in outlets or ducts. | <ul style="list-style-type: none"> a. Check internal surfaces of ducts and smooth out kinks or rough edges. b. Check for partly covered outlets, loose materials in ducts or fan housing and loose dampers in ducts. |
| Scraping Noise | |
| <ul style="list-style-type: none"> a. Fan hitting fan housing. | <ul style="list-style-type: none"> a. Adjust fan to turn free on all sides. Check motor bearings. Tighten motor mountings. |
| Rattle and Vibration Noises | |
| <ul style="list-style-type: none"> a. Loose ducts, tubing or compressor mounting. b. Cooling coil mounting screws loose. | <ul style="list-style-type: none"> a. Check duct, tubing, tubing clamps, compressor and compressor mounting for looseness and tighten where required. b. Tighten or install new screws. |
| Water Leaking or Dripping Into Passenger Compartment | |
| <ul style="list-style-type: none"> a. Drain tube stopped up. b. Drain tube disconnected. c. Felt baffle inside evaporator case dislodged. | <ul style="list-style-type: none"> a. Clean drain tube. b. Connect drain tube. c. Replace felt baffle. |
| Hissing Noise at Expansion Valve | |
| <ul style="list-style-type: none"> a. Shortage of refrigerant (indicated at sight glass). b. Restriction in liquid line. | <ul style="list-style-type: none"> a. Locate and repair leak and add refrigerant. b. Check receiver-dehydrator for partial stoppage. Check line for kinks. Check filter screen at expansion valve. |
| Partial Frosting and Sweating of Cooling Unit or Poor Cooling | |
| <ul style="list-style-type: none"> a. Improperly installed or adjusted controls. b. Shortage of refrigerant (indicated at sight glass). c. Restricted or clogged liquid line. d. Thermostatic switch improperly adjusted or relay malfunctioning. e. Expansion valve malfunctioning. f. Clutch will not disengage. | <ul style="list-style-type: none"> a. Check all controls for proper installation and adjustment. b. Locate and repair leak and add refrigerant. c. Check receiver-dehydrator for partial stoppage. Check line for kinks. d. Adjust thermostatic switch or check relay. e. Replace expansion valve. f. Check clutch. |

DIAGNOSIS (Continued)**Symptoms and Probable Cause****Diagnosis Procedures****Failure to Cool**

- a. Faulty thermostatic switch or relay operation
- b. Faulty clutch operation.

- c. Lost refrigerant charge (complete charge).
- d. Blower not operating properly.
- e. Insufficient air.

- f. Stopped up liquid line or receiver dehydrator.
- g. Faulty expansion valve.

- a. Replace faulty component.
- b. Check clutch actuating coil connections and coil. Check clutch for slippage by watching bolt in center of compressor shaft. Bolt should be turning at same speed as pulley. Check for belt slippage. Remove and check internal parts of clutch and replace where necessary.
- c. Locate and repair leak, process and charge system and check for proper oil level.
- d. Check electrical circuit. Check motor and fan.
- e. Check motor speed. Check for restrictions in ducts. Check for dirty evaporator coils. Remove coil to clean as necessary.
- f. Check for stoppage and replace if necessary.
- g. Expansion valve malfunctioning. Replace valve as required. Discharged power element. Replace valve. Stopped up expansion valve filter screen. If screen cannot be cleaned, the valve must be replaced.

Intermittent Failure to Cool

- a. Freeze-up in high humidity areas.
- b. Expansion valve loss of bulb charge.

- a. Raise low limit of thermostatic switch.
- b. Replace expansion valve.

Too Cool

- a. Faulty thermostatic switch.

- a. Check control panel linkage to switch, and adjust if necessary. Repair or replace unit as necessary.

High Gauge Reading on High Side of System

- a. Air or excessive refrigerant in system.
- b. Blocked air circulation through condenser.
- c. High engine temperature.

- a. Check complete system for leaks. Where detected, discharge system, repair leaks, then evacuate and recharge system with a complete charge.
- b. Clean condenser with stiff brush, compressed air or cool water. Never use steam!
- c. Perform required engine maintenance.

Low Gauge Reading on High Side of System

- a. Shortage of refrigerant.
- b. Faulty compressor.

- a. Check for shortage, locate leak and repair. Add refrigerant as required.
- b. Replace serviceable parts or compressor.

High Gauge Reading on Low Side of System

- a. Clutch slipping.
- b. Excessively high head or high side pressure.

- c. Over-feeding of expansion valve.
- d. Faulty compressor.

- a. Check clutch and make necessary repairs.
- b. Check system for leaks. Discharge system, repair any leaks found, then evacuate and recharge system.
- c. Check expansion valve for poor bulb contact to suction line.
- d. Repair or replace compressor if found to be faulty.

DIAGNOSIS (Continued)

Symptoms and Probable Cause

Diagnosis Procedures

Low Gauge Reading on Low Side of System

- a. Shortage of refrigerant.
- b. Restriction in liquid line, suction line, receiver-dehydrator or screen at expansion valve.
- c. Cooling coil dirty or iced up.

- a. Check for leak, repair leak and recharge system.
- b. Check lines for kinks and replace lines if kinks are found.
Check receiver-dehydrator. If partly stopped up, it will be cold or frosted.
Check expansion valve. If partly stopped up, it will be cold or frosted at that point.
- c. Check cooling coil. If dirty, clean coil with cold water. If iced up defrost coil and check thermostatic switch and expansion valve.

DIAGNOSIS SUMMARY

High Head Pressure Indications

- a. Air in system or overcharge of refrigerant.
- b. Blocked air circulation through condenser.
- c. High condensing medium temperature.

Low Head Pressure Indications

- a. Restricted expansion valve.
- b. Faulty compressor—will not pump.
- c. Shortage of refrigerant.
- d. Low condensing medium temperature.

Shortage of Refrigerant Indications

- a. Hissing noise at expansion valve.
- b. Sight glass shows bubbles or foam.
- c. High coil temperature.
- d. Low head pressure.
- e. Very little or no sweating.

Poor or No Refrigeration Indications

- a. Control panel linkage to water control valve or hot gas valve not installed or adjusted properly.
- b. Shortage of refrigerant.

- c. Improper adjustment of thermostatic switch.
- d. Expansion valve malfunctioning.
- e. Expansion valve bulb improperly located.
- f. Discharged thermobulb on expansion valve.
- g. Faulty compressor—will not pump.
- h. Heavy coating of frost or ice on cooling coil.
- i. Partially stopped up receiver-dehydrator, liquid line or suction line.
- j. Excessive head pressure.
- k. High condensing medium temperature.
- l. Clutch slipping.
- m. Clutch actuating coil not operating.

Needle Stuck Open in Expansion Valve

- a. Poor refrigeration.
- b. High head pressure.

Needle Stuck Shut in Expansion Valve

- a. No cooling.
- b. Very low back pressure reading.
- c. No refrigeration in cooling unit.

INITIAL CHECKS AND ADJUSTMENTS

Thermostatic Switch

Some adjustment is possible on this switch, located on the blower motor mounting bracket, in the event that an otherwise properly operating switch is not maintaining the proper suction pressure shown in the Performance Test chart. The adjustment screw is located beneath the fiber cover on the end of the switch opposite the thermostatic element.

Check and Adjustment

1. Before attempting to adjust the thermostatic switch, check to be sure that the adjustment lever on the switch is in maximum COLD position (fully forward toward the front of the car) when the COLD control knob on the control panel is pulled fully out. Readjust the bowden cable, if necessary (fig. 11-14). Then, if system still fails the performance test, proceed as follows:

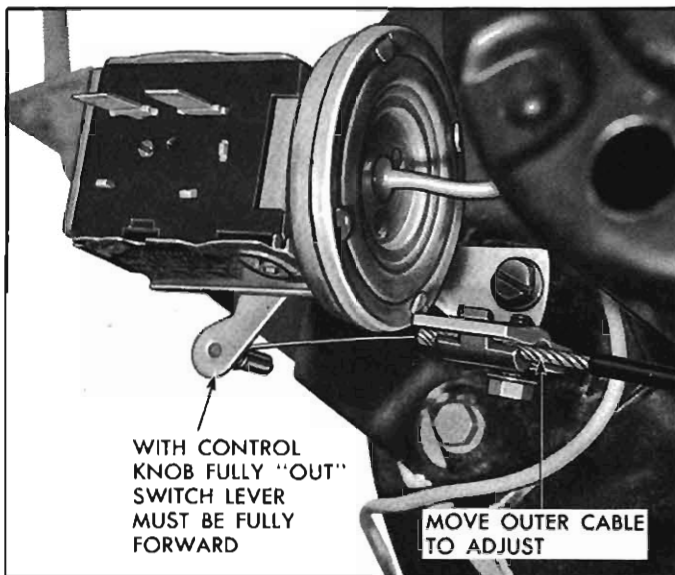

Fig. 11-14—Thermostatic Switch Cable Adjustment

2. Install the gauge set and set up vehicle as shown under "Performance Test."
3. Carefully remove the fiberboard cover by sliding it toward the left side of the vehicle. Using a small screwdriver, turn the adjustment screw (fig. 11-15) back and forth to check its performance. Use of a small mirror may aid in locating the adjustment screw.

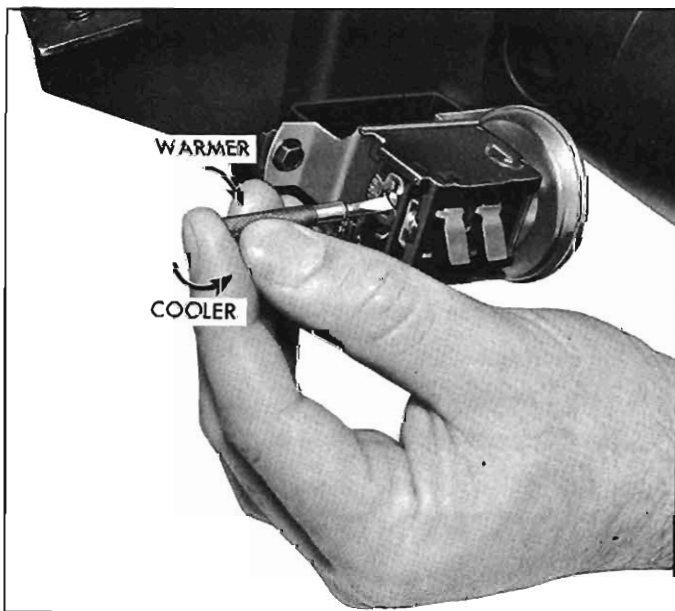

Fig. 11-15—Thermostatic Switch Adjustment

- If compressor continues to operate regardless of the screw adjustment, it indicates that the points are fused which will lead to evaporator freeze-up. Replace the switch.
- If the compressor does not operate regardless of

the position of the switch, a loss of thermostat bellows action is indicated. Replace the switch.

- Check the screw threads for stripped or otherwise damaged threads.
4. The suction side of the system, read on the low pressure gauge, should pull down to the pressure shown in the Performance Test chart, under the appropriate ambient air temperature heading.

NOTE: Providing that a fan is utilized as in Step 3 of "Performance Test," ambient air temperature will be considered the temperature of the shop at the time the switch is being set.

5. If, at the end of each cooling cycle, the low side has pulled down lower than the prescribed pressure, turn the adjusting screw clockwise in single turn increments until the suction pressure rises to the correct pressure.
6. If the pressure is more than it should be, turn the adjusting screw counterclockwise until the proper pressure is reached.

CAUTION: When checking and adjusting this valve, make certain that the adjustment lever is being held in the fully forward position described in Step 1 above.

7. After adjusting the switch, observe the operation of the system for several minutes. Then if the operation is satisfactory, remove the gauge set.
8. Replace the fiberboard cover over the adjustment screw. Check to see that the bowden cable is still in proper adjustment (lever fully forward when the COLD knob is pulled fully out).

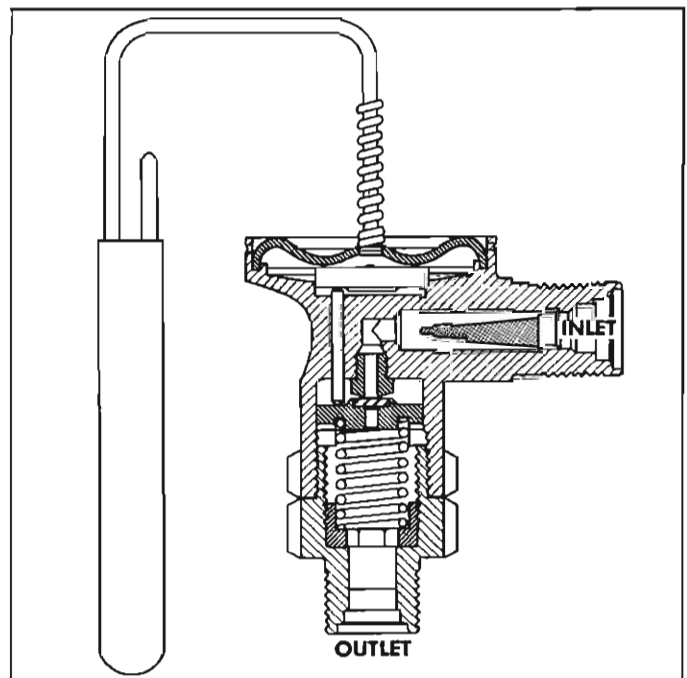

Fig. 11-16—Expansion Valve Cross Section

EXPANSION VALVE

A malfunction of the expansion valve (fig. 11-16) will be caused by one of the following conditions: valve stuck open, valve stuck closed, broken power element, a restricted screen or an improperly located or installed power element bulb. The first three conditions require valve replacement. The last two may be corrected by replacing the valve inlet screen and by properly installing the power element bulb.

Indications of expansion valve trouble provided by the Performance Test are as follows:

Valve Stuck Open or Broken Power Element

High Suction Pressure and High Head Pressure.
Noisy Compressor.
Poor Cooling—Freeze Up.

Valve Stuck Closed or Plugged Screen

Very Low Suction Pressure.
No Cooling.

Poorly Located Power Element Bulb

Normal Pressures.
Poor Cooling.

SYSTEM SERVICE OPERATIONS

1962-63 CORVAIR AIR CONDITIONING SYSTEM CAPACITIES

| | |
|--------------|-----------------------------|
| Freon Charge | 5 lbs. or 5 Cans |
| Oil Charge | 10 oz. of 525 Viscosity Oil |

PRECAUTIONS IN HANDLING REFRIGERANT LINES

- All metal tubing lines should be free of kinks, because of the restriction that kinks will offer to the flow of refrigerant. The refrigeration capacity of the entire system can be greatly reduced by a single kink.
- The flexible hose lines should never be bent to a radius of less than 10 times the diameter of the hose.
- The flexible hose lines should never be allowed to come within a distance of 2½" of the exhaust manifold.
- Flexible hose lines should be inspected at least once a year for leaks or brittleness. If found brittle or leaking they should be replaced with new lines.
- Use only sealed and dehydrated lines from parts stock.
- The use of the proper wrenches when making connections is important. The use of improper wrenches may damage the connection. The opposing fitting should always be backed up with a wrench to prevent distortion of connecting lines or components. When connecting the flexible hose connections it is important that the swaged fitting and the flare nut, as well as the coupling to which it is attached, be held at the same time using three different wrenches to prevent turning the fitting and damaging the ground seat.
- When disconnecting any fitting in the refrigeration system, the system must first be discharged of all refrigerant. However, proceed very cautiously regardless of gauge readings. Open very slowly, keep-

ing face and hands away so that no injury can occur if there happens to be liquid Freon in the line. If pressure is noticed when fitting is loosened, allow it to bleed off very slowly.

CAUTION: Always wear safety goggles when opening refrigerant lines.

- "O" rings and seats must be in perfect condition. The slightest burr or piece of dirt may cause a leak.
- In the event any line is opened to the atmosphere it should be immediately capped or plugged to prevent the entrance of moisture and dirt.

REFRIGERANT LINE CONNECTIONS

"O" Rings

These procedures must be followed when "O" ring connectors are serviced.

Always replace the "O" ring when a connection has been broken. When replacing the "O" ring, first dip it in refrigeration oil. Always use a backing wrench on "O" ring fittings to prevent the hose from twisting and damaging the "O" ring. Do not overtighten. Correct torque specifications are as follows:

| Metal Tube O.D. | Thread and Fitting Size | Steel Tubing Torque* | Alum. Tubing Torque* |
|-----------------|-------------------------|----------------------|----------------------|
| 1/4 | 7/16 | 10-15 | 5-7 |
| 3/8 | 5/8 | 30-35 | 11-13 |
| 1/2 | 3/4 | 30-35 | 11-13 |
| 5/8 | 7/8 | 30-35 | 18-21 |
| 3/4 | 1-1/16 | 30-35 | 23-28 |

*Foot Pounds

NOTE: Where steel to aluminum connections are being made, use torque for aluminum fittings.

Hose Clamps (Fig. 11-17 and 11-18)

With the exception of the adapter at the expansion valve inlet which has an "O" ring fitting, all hose connections are of the hose clamp type. Special procedures are necessary for both installation and removal.

NOTE: All hose clamps must be tightened after the first 1000 miles of operation.

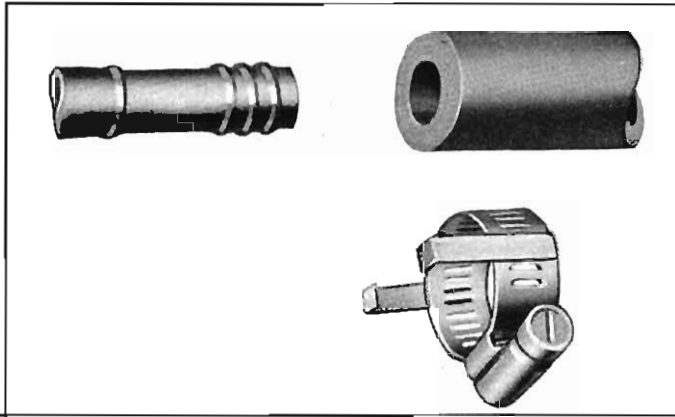

Fig. 11-17—Hose, Clamp and Fitting

Installation

1. Coat tube and hose with refrigeration oil.
2. Carefully insert hose over the three beads on the fitting and down as far as the fourth, or locating, bead. Hose must butt against this fourth bead.
CAUTION: Use no sealer of any kind.
3. Install clamps on hose, hooking the locating arms over the cut end of the hose.

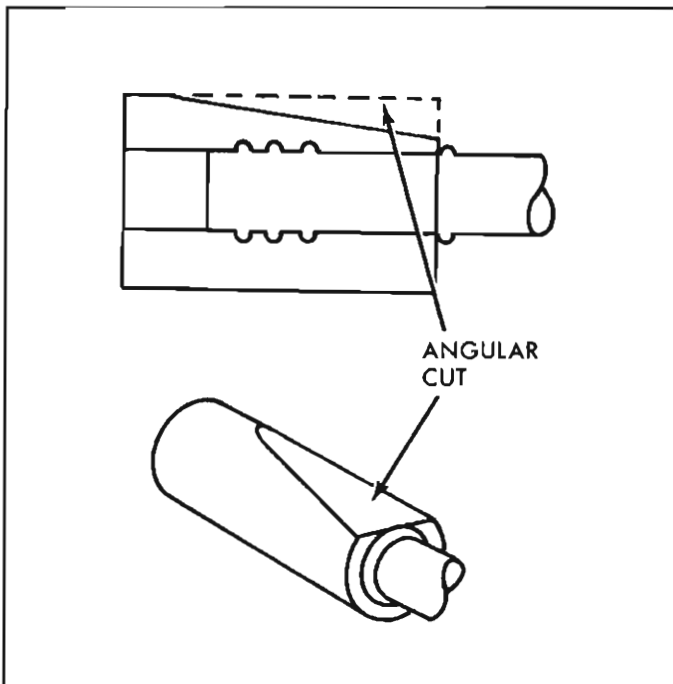

Fig. 11-18—Recommended Hose Removal Procedure

4. Tighten the hose clamp screw with a large screwdriver until the rubber of the hose protrudes through the slots in the clamp (40 inch lbs. torque).

Removal

1. Carefully, with a sharp knife, make an angle cut in the hose as shown in Figure 11-18. This should loosen the hose so that it may be worked off the fitting.

CAUTION: Use extreme care that the fitting is not scored by the knife when performing this operation. Such damage will lead to future Freon leaks.

2. Cut off slit end of hose when reinstalling. Reinstall as described above.

CAUTION: Use only approved refrigeration hose. Never use heater hose.

FREON HOSE FAILURE

After a leak or rupture has occurred in a Freon hose, or if a fitting has loosened and caused a considerable loss of Freon and oil, the entire system should be flushed and recharged after repairs have been made. If the system has been open to atmosphere for any prolonged period of time the receiver-dehydrator should be replaced.

CONDITIONING SYSTEM FOR REPLACEMENT OF COMPONENT PARTS

Air conditioning, like many other things, is fairly simple to service once it is understood. However, there are certain procedures, practices and precautions that should be followed to prevent costly repairs, personal injury or damage to equipment. For this reason it is strongly recommended that the preceding information in this section be studied thoroughly before attempting to service the Corvair System.

In removing and replacing any part in the refrigeration system, the following operations, which are described in this section must be performed in the sequence shown.

1. Purge the system by releasing the Freon to the atmosphere.
2. Remove and replace the defective part.
3. Charge the system with Freon-12.

CAUTION: Always wear protective goggles when working on refrigeration systems. Goggles J-5453 are included in the set of air conditioning special tools. Also, beware of the danger of carbon monoxide fumes by avoiding running the engine in closed or improperly ventilated garages.

INSTALLING GAUGE SET TO CHECK SYSTEM OPERATION

1. Install gauge adapter J-5420 onto the high pressure hose on the gauge set and J-9459 gauge adapter onto the low pressure hose.

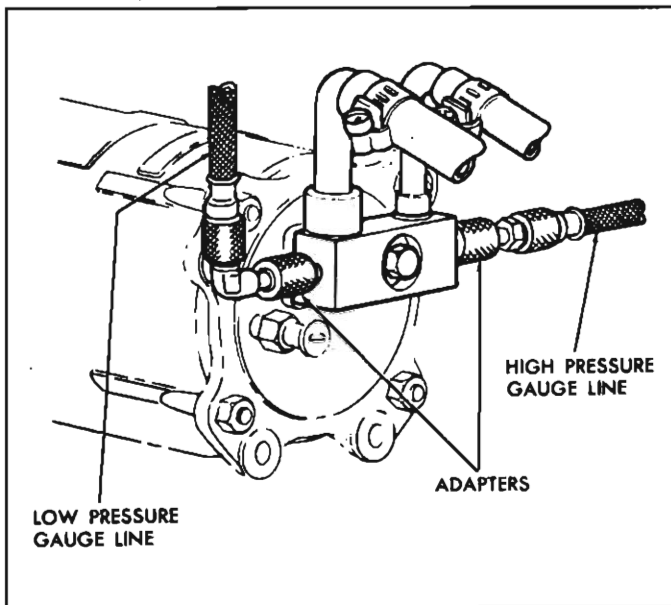

Fig. 11-19—Compressor Connector with Gauge Lines Installed

2. With engine stopped, remove the caps from the cored valve gauge fittings on the compressor connector.
3. Connect the gauge line adapters to the threaded fittings on the compressor connector, see Figure 11-19.

PURGING THE SYSTEM

In replacing any of the air conditioning components the system must be completely purged or drained of refrigerant. The purpose is to lower the pressure inside the system so that a component part can be safely removed.

1. With engine stopped install high and low pressure lines of gauge set to high and low pressure gauge outlets on compressor (see Installing Gauge Set to Check System Operation).
2. With plug removed from the centerline on the gauge manifold, open high pressure gauge valve and discharge the vapor slowly through the center connection.

CAUTION: Do not open valves too much or compressor oil may be discharged with the Freon. A rag wrapped around the end of the center gauge line will prevent the splashing of oil in the event of accidental rapid discharge.

3. When the pressure is reduced to below 100 pounds on the high pressure gauge, open the low pressure gauge valve and continue discharging until all refrigerant has been released or the pressure does not exceed 5 pounds. Close both gauge valves.

The complete system has now been purged of Freon and any part in the system can be replaced.

EVACUATING AND CHARGING THE SYSTEM

GENERAL NOTE: In all evacuating procedures shown below, the specification of 26-28 inches of Mercury vacuum is used. These figures are only attainable at or near Sea Level Elevation. For each 1000 feet above sea level where this operation is being performed, the specifications should be lowered by 1 inch. Example: at 5000 ft. elevation, only 21 to 23 inches of vacuum can normally be obtained.

Whenever the air conditioning system is opened for any reason, it should not be put into operation again until it has been evacuated to remove air and moisture which may have entered the system.

The proper method is to connect a vacuum pump, Tool J-5428, into the system as shown in Figure 11-20.

Use of the Freon Charging Station J-8393 greatly simplifies the charging procedure.

Adding Refrigerant

An important rule to follow in charging is that refrigerant should always be added to the compressor in a vaporous state. Another important rule is never to add refrigerant until the system has been leak tested and properly processed.

In order to charge refrigerant in the vapor state, the Freon-12 container will require the use of some heat. This can best be accomplished by placing the drum or cans in an upright position in a bucket or container of warm water. The temperature of the water should not exceed 125°F. Since the temperature of the water and drum or cans will decrease, as the vapor leaves the containers, the water and containers will be cooled. This may result in a lowering of the container pressure to the extent that it may be necessary to replenish or reheat the water unless an adequate amount of water is used.

With the compressor in operation, the head pressure should not exceed 275 lbs. and the pressure within the Freon containers should always be maintained at a minimum of 12 pounds and should not exceed a maximum of 90-100 pounds. When the low side valve on the gauge set is closed, the gauge will then indicate the low side pressure in the compressor. When the low side valve on the gauge set is open, the gauge indicates drum pressure. Refer to "General Information" for a description of gauge set valve operation.

Vacuum Pump Method For Evacuating And Charging

1. With the system completely purged, install the high and low pressure lines of the gauge set to the gauge fittings on the compressor if this has not previously been done.
2. Install center gauge line to tee connector Tool J-5462-2.

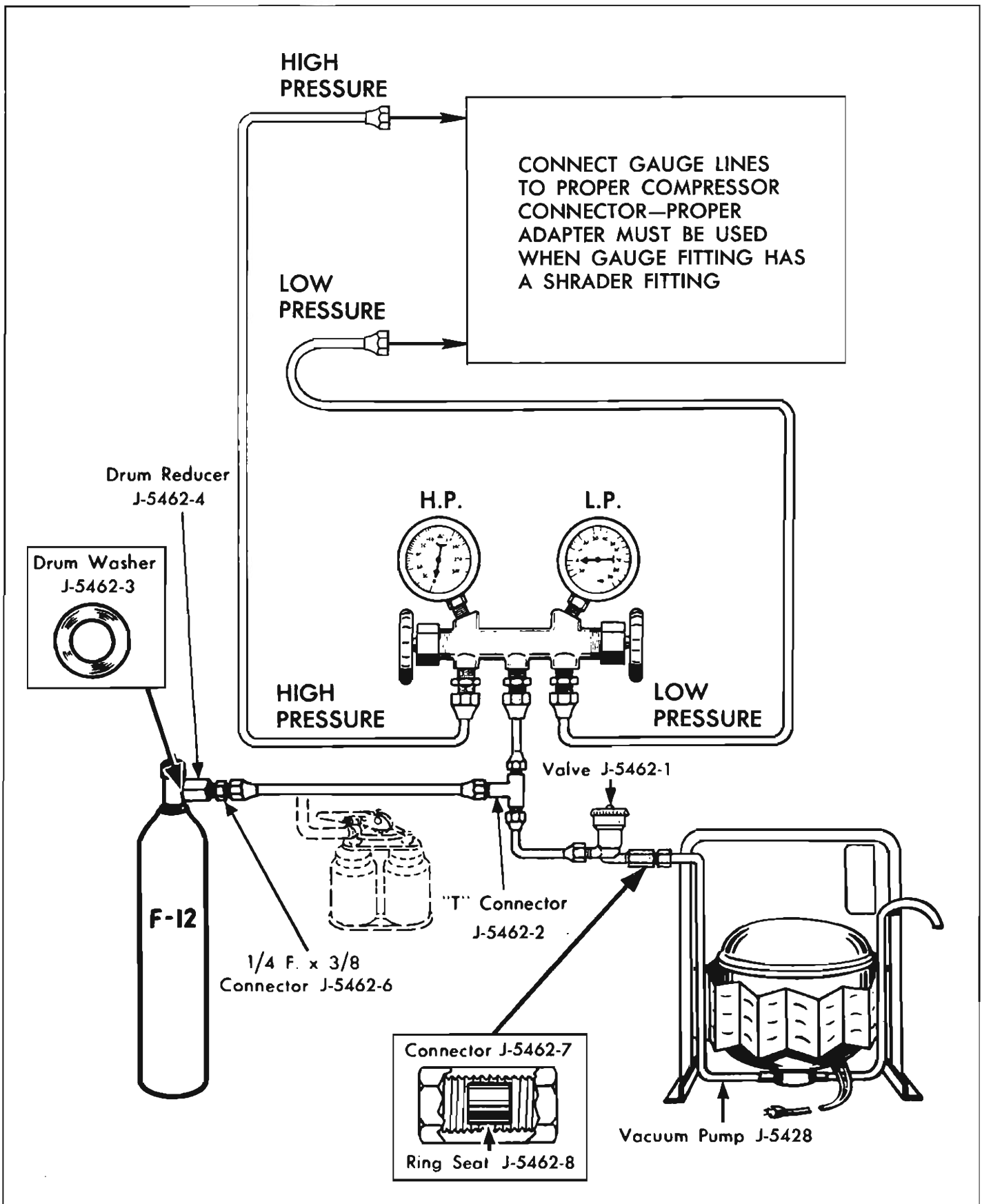

Fig. 11-20—Gauge Connections for Evacuating and Charging System

3. Install female connector (Tool J-5462-7) at the inlet side of the vacuum pump.
4. Insert flare seat (Tool J-5462-8) into connector J-5462-7 at the vacuum pump.
5. Install shutoff valve (Tool J-5462-1) to the connector at the vacuum pump.
6. Install a gauge line from one side of tee connector to the valve at the vacuum pump. The valve should be closed.
7. Install the gauge line from the remaining tee connection to a drum of Freon-12 or to 3 full cans of Freon-12 in Tool J-6272. When using a drum, it will be necessary to use fitting (Tool J-5462-9) and reducer (Tool J-5462-4) with lead washer (Tool J-5462-3) between the gauge line and drum.
8. Check level of fluid in vacuum pump and add Frigidaire 150 viscosity oil if necessary to bring to proper level. Also make sure dust cap on discharge side of vacuum pump has been removed.

NOTE: Information on servicing the vacuum pump in event of low fluid level or failure to start is described under "Vacuum Pump."
9. Open high and low pressure gauge valves.

CAUTION: Shutoff valve at vacuum pump must be closed. If pressure enters pump, cover may blow off.
10. Start the vacuum pump and *slowly* open the hand shutoff valve at the pump to avoid forcing oil out of the pump. A vacuum is now being drawn on both the high and low pressure sides of the system at the same time.

NOTE: If oil is blown from the pump it should be refilled to proper level with Frigidaire 150 viscosity oil as described under "Basic Service Information."
11. Operate the pump to obtain approx. 28" vacuum for 10 minutes. If approx. 28" vacuum cannot be obtained, close the shutoff valve at the pump and stop the pump. Note the low pressure gauge to see if the vacuum holds. If the vacuum holds, the pump or gauge may be faulty. If vacuum will not hold, open refrigerant cylinder valve to charge system to cylinder pressure and check system and gauge hookup for leaks with leak detector, Tool J-6084. After locating leak, discharge system of Freon, repair leak and repeat operation to obtain approx. 28" vacuum for 10 minutes.
12. Close hand shutoff valve at pump, stop pump and observe low pressure gauge to see that 28" of vacuum holds for 3 minutes. If vacuum does not hold, check for leaks as described in Step 11. If vacuum holds or if any leaks found have been repaired, proceed with Step 13.
13. Open the Freon container valve to charge the system to cylinder pressure, then close valve.
14. Discharge system, then evacuate the system again at approx. 28" vacuum for 10 minutes. This second evacuation is to remove any air or moisture that may have remained in the system.
15. Close gauge valve.

The system is now ready for a complete charge of Freon-12. (See "Air Conditioning System Capacities".) Do not remove the gauge connections but proceed with the charging operation.

Complete Charge—Vacuum Pump Method

If the entire charge of refrigerant has been lost through accident or in the replacement of any of the components, a complete charge will be necessary and should be added *after evacuation* as described below.

1. With gauge set, adapters and Freon drum (or cans) installed as shown in Figure 11-20, make sure high and low pressure gauge valves and the valve on the Freon drum are closed.
2. Open low pressure gauge valve.
3. If using a drum of Freon place drum on scales and weigh accurately. This is to determine amount of Freon used. Set drum (or cans) in pail of water heated to not more than 125°F. If pail of water is used, weigh it with Freon drum.

NOTE: If the disposable cans of Freon are used, the scales can be eliminated since 5 cans comprise a complete charge.

4. Open the valve wide on the Freon drum or 3 can fixture. Freon-12 vapor under pressure will flow into the system without operating the compressor. This amount should not exceed the full charge shown on page 11-15. Close low pressure valve in gauge set at frequent intervals to be certain pressure in the low side is always maintained above 12 lbs.

NOTE: If it is not possible to charge the entire amount of Freon by this method, then operate the engine and compressor at 1000 rpm minimum to complete the charging operation. To insure operation of the compressor during charging, the clutch actuating coil can be energized by connecting a wire from the battery positive terminal to the coil. The pulley nut on the end of the compressor shaft will rotate with the compressor engaged.

5. When the full charge of Freon has entered the system, close the Freon container valve and the low pressure gauge valve. The engine can be operated at 1500 RPM to observe high and low pressure gauges as well as sight glass and general performance of the system.
6. Stop engine.
7. Remove the gauge set and jumper wire, replace caps on gauge fittings.

J-8393 Freon Charging Station Method For Evacuating and Charging

The J-8393 Freon Charging Station (figs 11-21 and 11-22) is a portable assembly of a vacuum pump, Freon supply, gauges, valves, and most important, a five (5) pound metering Freon charging cylinder. The use of a charging cylinder eliminates the need for scales, hot water pails, etc.

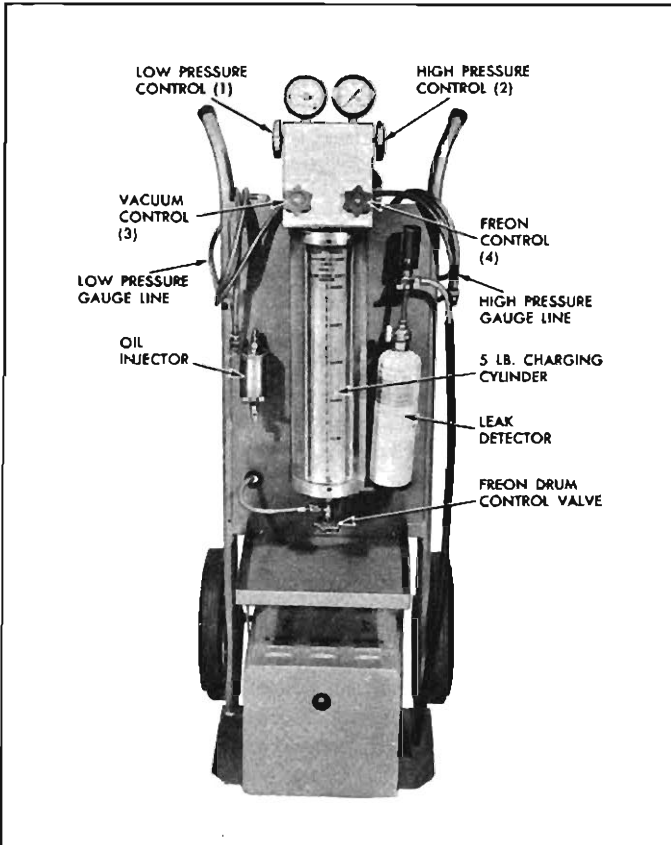

Fig. 11-21—J-8393 Freon Charging Station

The chief advantage of this unit is savings. A very definite savings in Freon and time can be obtained by using this unit. Since the Freon is metered into the system by volume, the correct amount may be added to the system and charged to the customer. This, coupled with the fact that the unit remains "plumbed" at all times and thus eliminates loss of Freon in purging of lines and hooking-up, combines to enable the operator to get full use of all Freon purchased by the dealership.

All evacuation and charging equipment is hooked together in a compact portable unit (fig. 11-21) which nearly anyone can use to do an adequate job of servicing a car air conditioner. It brings air conditioning service down to the basic problem of hooking on two hoses, and manipulating clearly labelled valves.

This will tend to insure that the job will be done without skipping operations. As a result, you can ex-

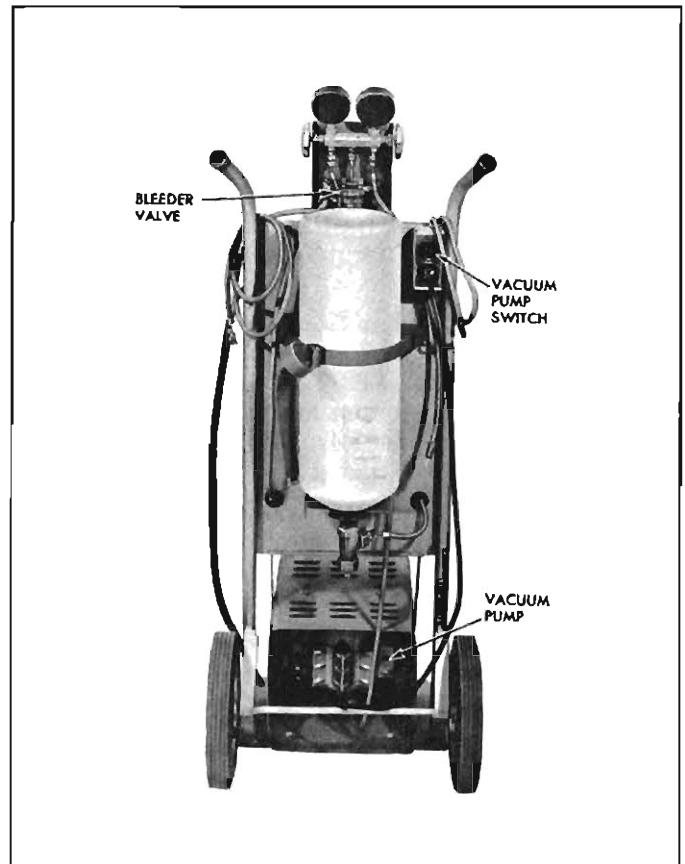

Fig. 11-22—J-8393 Freon Charging Station—Rear View

pect to save time and get higher quality work, less chance of an over or undercharge, or comeback.

The pump mount is such that the dealer may use his own vacuum pump. The gauges and manifold are in common use. Thus a current air conditioning dealer can use the equipment on hand and avoid duplication.

Filling Charging Cylinder

1. Open control valve on Freon drum.
2. Open valve on bottom of charging cylinder allowing Freon to enter cylinder.
3. Bleed cylinder Freon valve on top (behind control panel) as required to allow Freon to enter. When Freon reaches desired level (see "Air Conditioning System Capacities") close valve at bottom of cylinder and be certain bleed valve is closed securely.

NOTE: It will be necessary to close bleed valve periodically to allow boiling to subside to check level in sight glass.

Installing Charging Station to System

1. Be certain all valves on charging station are closed.
2. Connect high pressure gauge line to high pressure gauge fitting. (See "Installing Gauge Set to Check System Operations.")

3. See Figure 11-21. Turn high pressure control (2) one turn counter-clockwise (open). Crack open low pressure control (1) and allow Freon gas to hiss from low pressure gauge line for three seconds, then connect low pressure gauge line to low pressure gauge fitting on compressor.
5. System is now ready for performance testing.

Evacuating and Charging System

1. Install charging station as previously described. Refer to Figure 11-21 while performing the following operation.
2. Remove Low Pressure gauge line from compressor.

NOTE: Remove the adapter from the gauge fitting.
3. Crack open high (2) and low (1) pressure control valves, and allow Freon gas to purge from system. Purge slow enough so that oil does not escape from system along with Freon.
4. When Freon flow nearly stops, connect Low Pressure gauge line to compressor.
5. Turn on vacuum pump and open Vacuum Control Valve (3).
6. With system purged as above, run pump until 28-29 inches of vacuum is obtained. Continue to run pump for 15 minutes after the system reaches 28-29 inches vacuum.
7. If 28-29 inches cannot be obtained, close Vacuum Control Valve (3) and shut off vacuum pump. Open Freon Control Valve (4) and allow ½ pound of Freon to enter system. Locate and repair all leaks.
8. After evacuating for 15 minutes, add ½ pound of Freon to system as described in step 7 above. Purge this ½ pound and reevacuate for 5 minutes. This second evacuation is to be certain that as much contamination is removed from the system as possible.
9. Only after evacuating as above, system is ready for charging. Note reading on sight glass of charging cylinder. If it does not contain a sufficient amount for a full charge, fill to the proper level.
10. Close Low-Pressure valve (1). Fully open Freon Control Valve (4) and allow all liquid Freon to enter system. When full charge of Freon has entered system, turn off Freon Control Valve (4) and close hand shut-off valves.
11. If full charge of Freon will not enter system in step 3 above, close high pressure control, and Freon Control Valve (4). Start engine and run at slow idle with compressor operating. Crack Freon Control Valve (4) and Low Pressure Control (1). Watch low side gauge and keep gauge below 50 psi by regulating Freon Control Valve (4). Closing valve will lower pressure. This is to prevent liquid Freon from reaching the compressor while the compressor is operating. When required charge has entered system, close Freon Control

- Valve (4) and close Low Pressure Control (1).
12. System is now charged and should be performance tested before removing gauges.

CHECKING AND ADDING OIL

Compressors are originally fully charged with 10 oz. of Special Frigidaire 525 viscosity refrigeration oil. Design and configuration of the six cylinder compressor require a radical departure from the oil checking procedure used on the five cylinder compressor in past years.

In the six cylinder compressor it is not recommended that the oil be checked as a matter of course. Generally, compressor oil level should be checked only where there is evidence of a major loss of system oil such as might be caused by:

- A broken refrigerant hose.
- A severe hose fitting leak.
- A very badly leaking compressor seal.
- Collision damage to the system components.

To check the compressor oil charge, it is necessary to remove the compressor from the vehicle, drain and measure the oil.

Checking Compressor Oil Charge

1. Run the system for 10 minutes at 1000-1500 engine rpm with controls set for maximum cooling and high blower speed.
2. Turn off engine, evacuate the system, remove compressor from vehicle, place it in a horizontal position with the drain plug downward and drain the oil into a clean container, measure and discard the oil.
3.
 - a. If the quantity drained was 4 fluid oz. or more, add the same amount of new refrigeration oil to the replacement compressor.
 - b. If the quantity drained was less than 4 fluid oz., add 6 fluid oz. of new refrigeration oil to the replacement compressor.
 - c. If a new service compressor is being installed, drain all oil from it and replace only the amount specified in Steps 3a and 3b above.
 - d. If a field repaired compressor is being installed, add an additional 1 fluid oz. to the compressor.
4. In the event that it is not possible to idle the compressor as outlined in Step 1 to effect oil return to it, proceed as follows:
 - a. Remove the compressor, drain, measure and discard the oil.
 - b. If the amount drained is more than 1½ fluid oz. and the system shows no signs of a major leak, add the same amount to the replacement compressor.
 - c. If the amount drained is less than 1½ fluid oz. and the system appears to have lost an excessive amount of oil, add 6 fluid oz. of clean refrigeration oil to replacement compressor, 7 fluid oz. to a repaired compressor.

If the oil contains chips or other foreign material, replace the receiver-dehydrator and flush or replace all component parts as necessary. Add the full 10 fluid oz. of new refrigeration oil to the replacement compressor.

NOTE: When adding oil to the compressor, it will be necessary to tilt the rear end of the compressor up so that the oil will not run out of the suction and discharge ports. Do not set the compressor on the shaft end.

5. Add additional oil in the following amounts for any system components being replaced.

| | |
|---------------------|-------------|
| Evaporator | 3 fluid oz. |
| Condenser | 1 fluid oz. |
| Receiver-dehydrator | 1 fluid oz. |

AIR OR EXCESSIVE REFRIGERANT IN THE SYSTEM

This procedure is to be used when a diagnosis indicates either air or excessive refrigerant in the system. When a higher than normal high side operating pressure is encountered (see "Service Diagnosis"), then proceed as previously described under "Purging the System," "Evacuating the System" and "Adding Refrigerant—Complete Charge."

COMPONENT PARTS SERVICE OPERATIONS

EVAPORATOR

Removal from Vehicle (Refer to Fig. 11-23)

1. Purge the system of refrigerant.

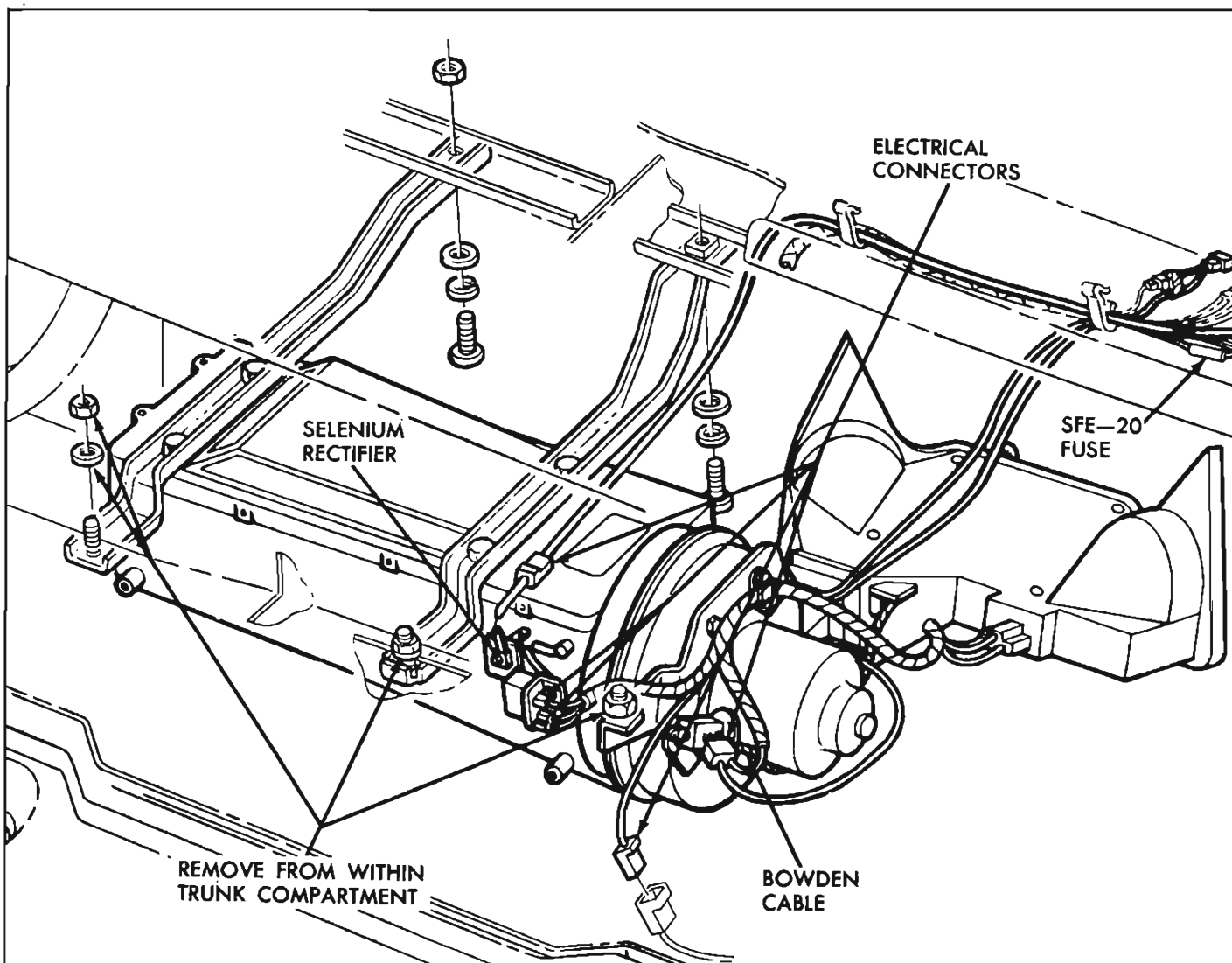

Fig. 11-23—Evaporator Removal

2. Disconnect electrical connections from the thermostatic switch and blower motor and the bowden cable from thermostatic switch.
3. In trunk compartment, remove 3 stud nuts attaching right and left evaporator brackets and blower bracket to body panel.

NOTE: Evaporator case must be supported before removing these nuts.

4. While still supporting the evaporator case, remove the two screws attaching the mounting brackets to the instrument panel and the screw attaching the control assembly to the blower case. Carefully lower evaporator case and blower assembly, withdrawing blower flange from control assembly.
5. Pull evaporator case and blower assembly out far enough so that the electrical connectors to the compressor relay and the selenium rectifier yellow wire may be removed. Remove both drain tubes.
6. Disconnect the high and low pressure lines at the evaporator. Immediately cap lines to prevent entrance of moisture.

CAUTION: Even though the system has been purged, safety goggles should be worn when disconnecting refrigerant lines. Goggles will eliminate the possibility of eye damage from latent freon in the system.

7. Remove the unit from the vehicle.

Core Replacement

1. Remove the thirteen screws attaching the cover to the evaporator case.
2. Lift the evaporator core assembly (including cover and mounting brackets) out of the evaporator case (fig. 11-24).

NOTE: Removal of the expansion valve or thermostatic switch may be performed at this time.

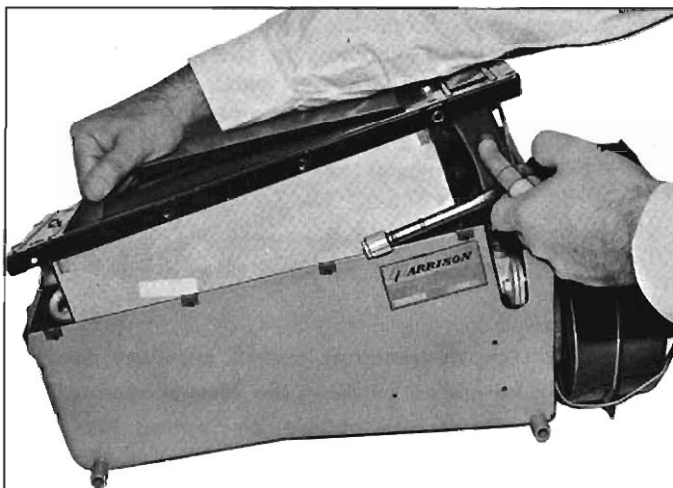

Fig. 11-24—Removing Evaporator Core

3. Remove the six screws attaching the cover and mounting brackets to the core.
4. Remove expansion valve (fig. 11-25) from core and install on replacement core. See "Expansion Valve-Replacement."

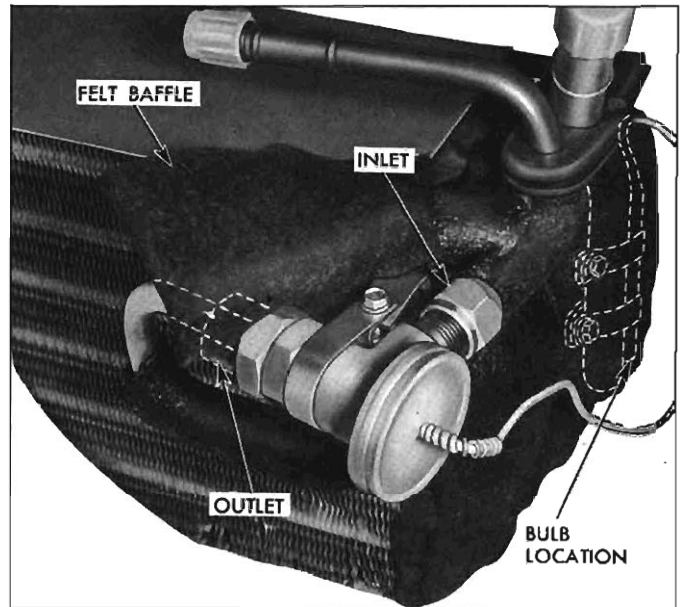

Fig. 11-25—Expansion Valve Connections

5. Re-install the core and expansion valve assembly into the evaporator case, by reversing the removal procedure.

NOTE: If the blower housing was disassembled from the evaporator case, position the thermostatic switch capillary tube (fig. 11-27) and reassemble the blower to the evaporator case, before installing the evaporator core assembly into the evaporator case.

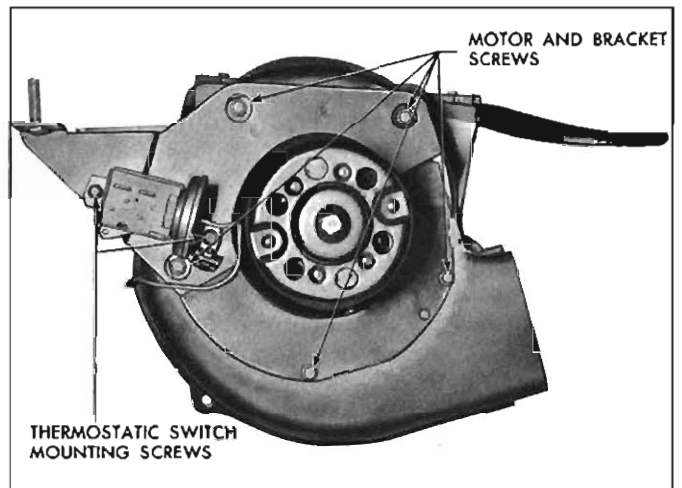

Fig. 11-26—Blower Motor Attaching Screws

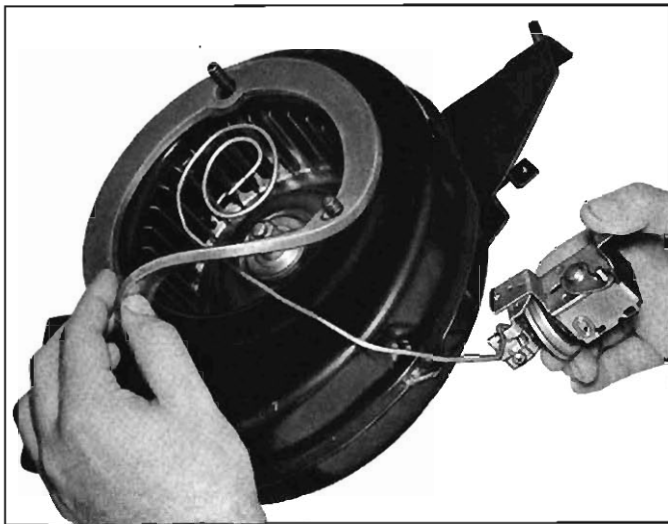

Fig. 11-27—Thermostatic Switch Removal

Installation in Vehicle

1. Install the hose clamp connections.
2. Install the two drain tubes, and the wiring connectors to the relay and selenium rectifier assembly.
3. Install evaporator case and blower assembly in vehicle, carefully guiding blower case flange into control assembly.
4. Install the two screws attaching the evaporator case to the instrument panel and the single screw attaching the blower case to the control assembly. With the evaporator supported, replace 3 stud nuts and washers attaching case and blower brackets to the body panel within the trunk compartment.
5. Install wiring connector and bowden cable on thermostatic switch and wiring connector on blower motor.

Check for proper adjustment on bowden cable to thermostatic switch.

EXPANSION VALVE

The thermostatic expansion valve is factory adjusted and pre-set and cannot be adjusted after installation. A malfunctioning valve must be replaced. However, before proceeding, check all other possible causes of the trouble. Make certain that the power element bulb is properly positioned on the low pressure line, tightly clamped and has the insulation in place. Make certain the liquid inlet screen between valve and receiver-dehydrator line is not clogged. After checking the screen and the location and mounting of the thermobulb, proceed with replacement of the valve assembly. A malfunctioning valve may result from a stuck open or shut needle caused by corrosion, or a discharged power element caused by a broken capillary line or tip.

Replacement

1. Remove the evaporator case from the vehicle and the core from the case as previously described.
2. See Fig. 11-25. Disconnect the pipe fittings from the expansion valve and remove the valve and capillary tubing. Note the position of the felt baffle on the core and expansion valve.
3. Install the new expansion valve and capillary tubing. Cement felt baffle in proper position on new valve.

NOTE: Locate expansion valve bulb in same location as found on original unit. Bulb must contact pipe along its entire length. The insulation must be replaced with no air leaks.

4. Insert evaporator assembly in the evaporator case and install in vehicle.

THERMOSTATIC SWITCH OR BLOWER MOTOR

Replacement

1. Remove electrical leads at thermostatic switch and blower motor.
2. Remove the bowden cable at the thermostatic switch and remove the two thermostatic switch mounting screws.
3. From luggage compartment side of dash, remove the nut from the blower motor bracket stud. Remove the 5 screws in the blower motor mounting plate (see fig. 11-26), then withdraw the blower motor assembly from the blower housing.

NOTE: If a new blower motor is to be installed, disassemble the vaned blower assembly from the motor being removed.

4. If the thermostatic switch is to be removed, remove nuts from the two lower studs attaching the blower housing to the evaporator case. Pull lightly on the lower portion of the blower housing to achieve a slight opening between the blower housing and evaporator case, thereby permitting withdrawal of the thermostatic switch capillary tube. See fig. 11-27.
5. To install a new blower motor or thermostatic switch, reverse the removal procedure described above.

NOTE: The thermostatic switch capillary tube should be routed between the blower case and rubber gasket and should be formed into a circular shape in the air passage between the evaporator and blower. Switch operation should be checked after installation is completed.

CONTROL PANEL ASSEMBLY

Removal (fig. 11-28)

1. From the underside of the control panel, remove the four long screws that attach the control panel assembly to the radio case.
2. Lower assembly and unplug wiring connectors from assembly and relay.
3. Remove bowden cable from thermostatic switch.
4. Control panel assembly may now be removed from vehicle.

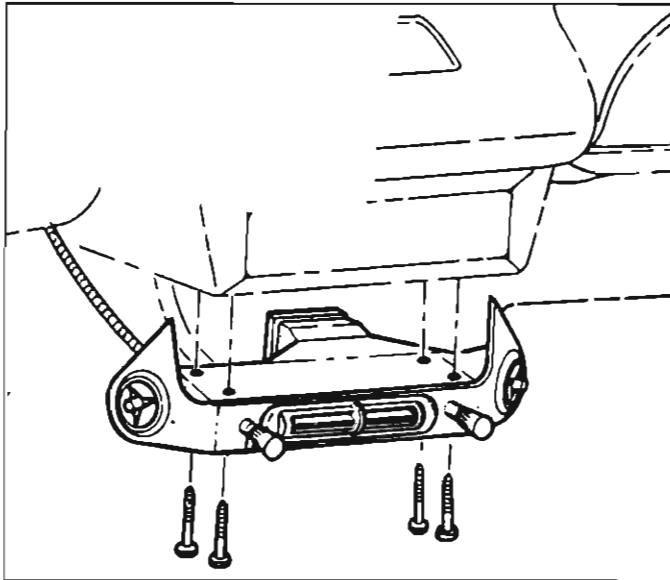

Fig. 11-28—Control Panel Assembly Removal

Installation

1. Reinstall wiring connectors to rear of control assembly and to the relay.
2. Carefully place the control assembly in the proper position, making sure that the blower case flange is correctly installed in the control assembly.
3. Replace the four control assembly to radio case attaching screws.
4. Attach bowden cable to the thermostatic switch and check for proper adjustment.

Blower Switch Replacement

1. Remove the control assembly from the vehicle as outlined under "Control Assembly—Removal" except that it will not be necessary to remove the wiring connectors and bowden cable.
2. Remove the seven philips head screws attaching the cover to the assembly. Fold the cover back, being careful not to rip the rubber gasket at the rear of the assembly. The gasket need not be unstapled from the cover.
3. Pull control knob off of the blower switch.

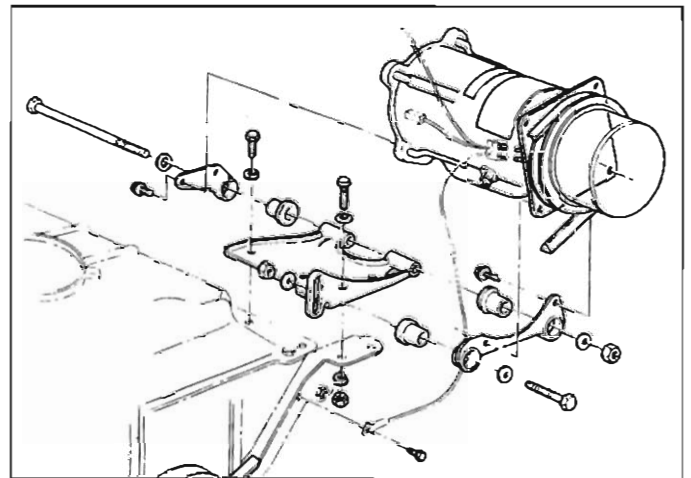

Fig. 11-29—Compressor Mounting

4. Using Tool J-7673 (Windshield Wiper Control and Light Switch Nut Wrench), remove the spanner nut attaching the blower switch to the control assembly case.
5. Remove the switch and spacer from the case and remove wiring connectors. Note location of the connectors before removal.
6. Replace the wiring connectors in their proper place on a new switch and reinstall the switch and spacer in the case using Tool J-7673 to tighten spanner nut.
7. Replace control knob and control assembly cover.
8. Reinstall control assembly.

COMPRESSOR

In the 1961 Corvair Air Conditioning System, a malfunctioning compressor had to be replaced with a service compressor because the internal mechanism was not considered field serviceable. This situation has been remedied in the 1962 air conditioning system through the use of the completely new six cylinder compressor. The new compressor (fig. 11-30) is so constructed that the entire internal mechanism may be serviced as a unit or, if so desired, may be completely disassembled for replacement of components. These service operations, with the aid of trained personnel and the proper service tools, may be simply and easily performed, eliminating the costly necessity of replacing the entire compressor.

Removal

(See fig. 11-29)

NOTE: If the compressor is being removed to gain access to engine components or to service only the compressor clutch coil or pulley assembly, it will not be necessary to purge the system. In that case, disregard steps 1 and 2 below.

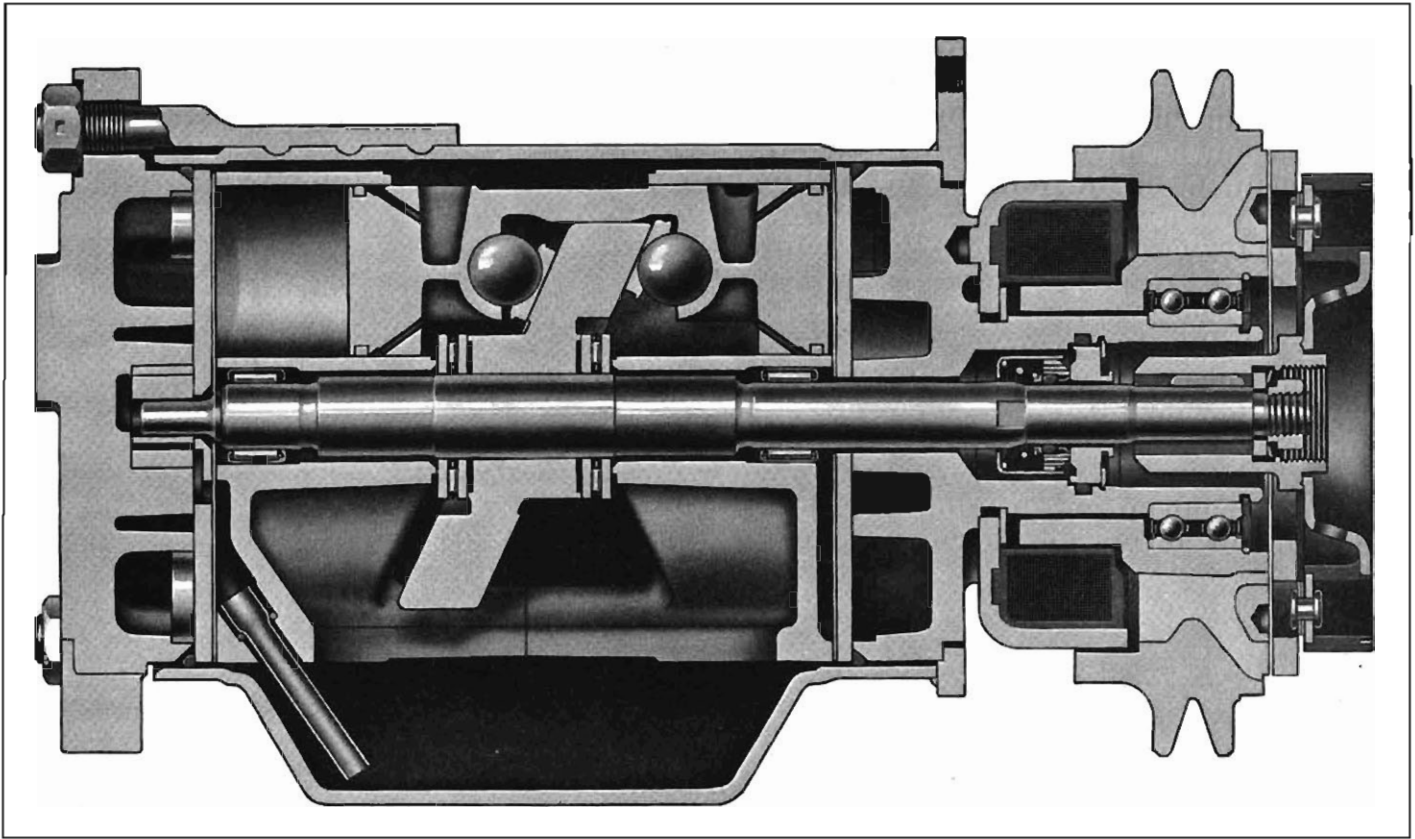

Fig. 11-30—Six Cylinder Compressor—Sectional View

1. Purge the refrigerant from the system.
2. Remove the bolt attaching the fittings block to the front of the compressor and remove the block. Cap the openings in the block and swing the lines and fittings block out of the way.
3. Remove the nut from the compressor mounting bracket pivot bolt and remove the compressor-to-adjusting bracket attaching parts. Remove the compressor drive belt.
4. Disconnect the compressor electrical feed and ground wires.
5. Remove the three bolts attaching the triangular bracket to the front of compressor.
6. Work the long pivot bolt forward until the threaded end is moved out of the compressor rear mounting boss. Lift the compressor from the vehicle, or reposition in compartment if service work is to be done with the refrigerant lines connected.
7. Since the service compressor, if used, will be received less the clutch actuating coil parts and clutch pulley assembly, these components, if in satisfactory condition, should be removed from the malfunctioning compressor and installed on the new compressor.

NOTE: Drain and measure oil in the compressor when it is removed.

Installation

1. Replace oil in compressor. See "Checking and Adding Oil".
 2. Remove the valve cover shipping plate and "O" rings. Install the connector to the new compressor using new "O" rings. Torque the attaching bolt to 17 to 23 ft. lbs.
- NOTE:** Disregard Steps 1 and 2 if compressor was removed to gain access to engine.
3. Support the compressor on the mounting bracket and work the mounting bracket pivot bolt rearward, through the compressor rear mounting boss. Loosely install the washer and nut on the pivot bolt.
 4. Install the three bolts attaching the triangular bracket to the front of compressor.
 5. Connect the compressor electrical feed and ground wires.
 6. Install compressor drive belt and compressor-to-adjusting bracket attaching parts.
 7. Adjust belt tension, then tighten pivot bolt nut to apply light pressure on rubber mounting.

MINOR SERVICE OPERATIONS

Hub and Drive Plate, Pulley, and Coil Housing

Service operations may be performed on the hub and drive plate, pulley and bearing assembly and coil housing assembly without the necessity of purging the refrigerant from the system or removing the compressor from the vehicle. The shaft seal assembly may also be serviced without removing the compressor from the vehicle but the refrigerant must first be purged from the system.

Pictures used in describing these operations show the compressor removed from the vehicle to more clearly illustrate the various operations.

Hub and Drive Plate

Removal

1. If disassembly is being performed on a bench, mount support bracket J-9396 in a vice and attach the compressor to the bracket.
2. Using drive plate holding tool J-9403 and socket J-9399, remove the locknut from the shaft (fig. 11-31). Discard locknut.

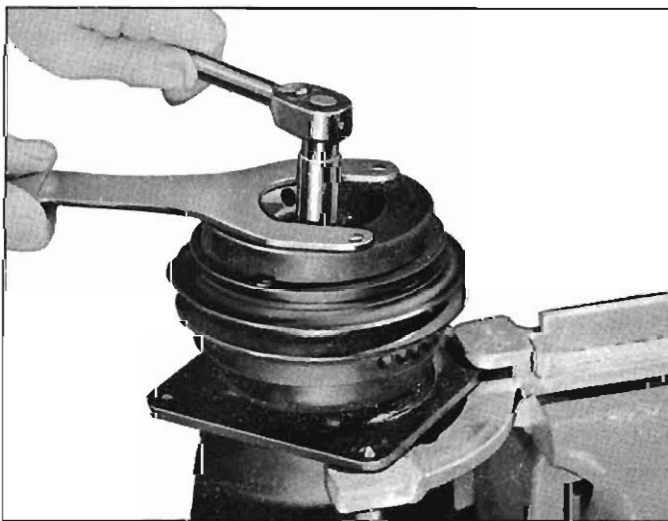

Fig. 11-31—Removing Shaft Locknut

3. Use snap ring pliers J-5403 to remove the retainer ring. Then remove the hub spacer.

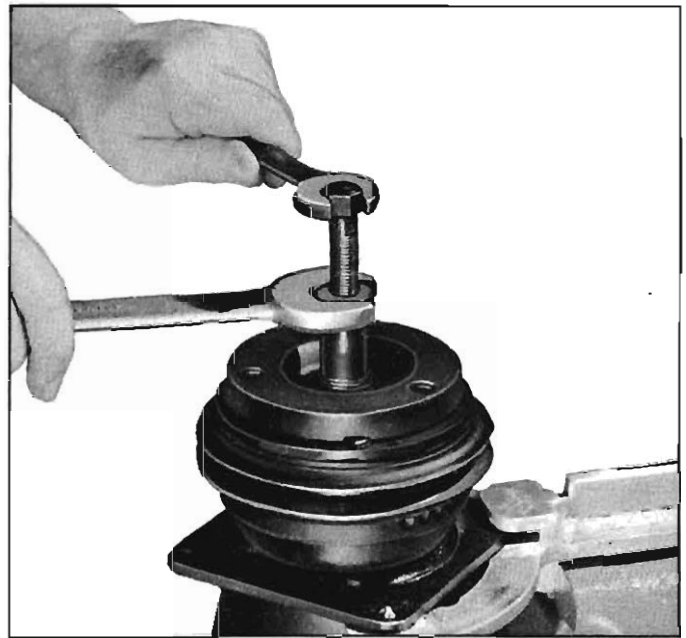

Fig. 11-32—Removing Hub and Drive Plate Assembly

4. Tool J-9401 may now be used to remove the hub and drive plate assembly (fig. 11-32).

NOTE: Carefully snug tool into place with wrench to insure engagement with threads.

Inspection

If the frictional surface shows signs of warpage due to excessive heat, the hub and drive plate should be replaced.

Installation

NOTE: When hub and drive plate assembly is ready for installation, clean its frictional face with a suitable cleaner.

1. Insert the square hub and drive plate key into the keyway in the drive shaft allowing it to project approximately $\frac{3}{16}$ " out of the end of the keyway (fig. 11-33).
2. Line up the key in the shaft with the keyway in the hub.



Fig. 11-33—Drive Plate Key Installed in Keyway

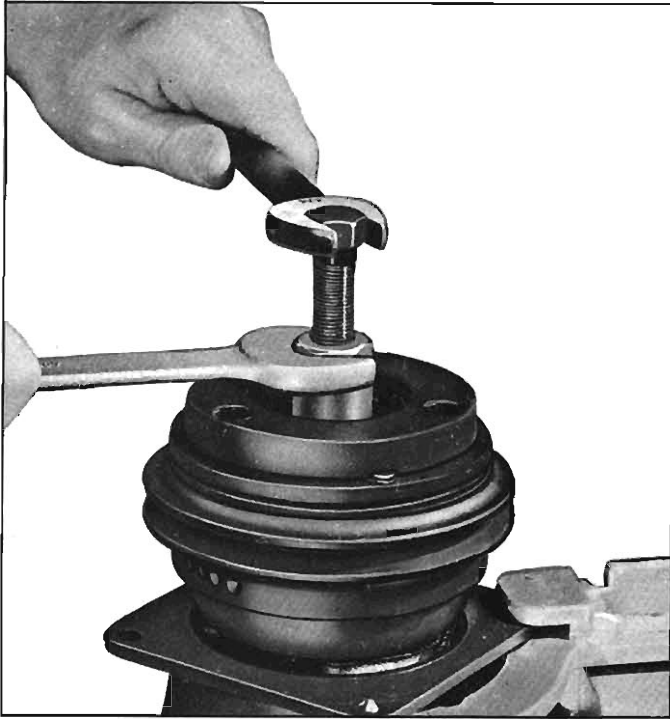

Fig. 11-34—Installing Hub and Drive Plate Assembly

3. Using Tool J-9480 and washer J-9480-2 (fig. 11-34), install the hub and drive plate assembly. Pull the assembly onto the shaft until there is approximately $\frac{3}{32}$ " space between the frictional surfaces of the drive plate and pulley. (A ZERO thrust race is approximately $\frac{3}{32}$ " in thickness and may be used to roughly gauge this operation.)

NOTE: Use Tool J-9403 to hold hub and drive plate if necessary.

4. Install the hub spacer washer and, using snap ring pliers J-5403, install the retainer ring, convex side of ring facing washer.
5. Use J-9399 and J-9403 to install a new locknut. Tighten the nut to 14-16 ft. lbs. torque. Air gap between the frictional faces should now be .022" to .068" ($\frac{1}{32}$ " to $\frac{1}{16}$ ").

NOTE: Notch on the locknut must face towards retainer ring.

6. The pulley should now rotate freely.

CAUTION: Never pound or drive the hub and drive plate into position. Always use the proper tools when removing or replacing clutch parts. Failure to do so may result in serious internal compressor damage.

7. Operate the refrigeration system and rapidly cycle the clutch (by turning the air conditioning off and on at least 20 times at approximately one second intervals) to seat the mating parts of the clutch.

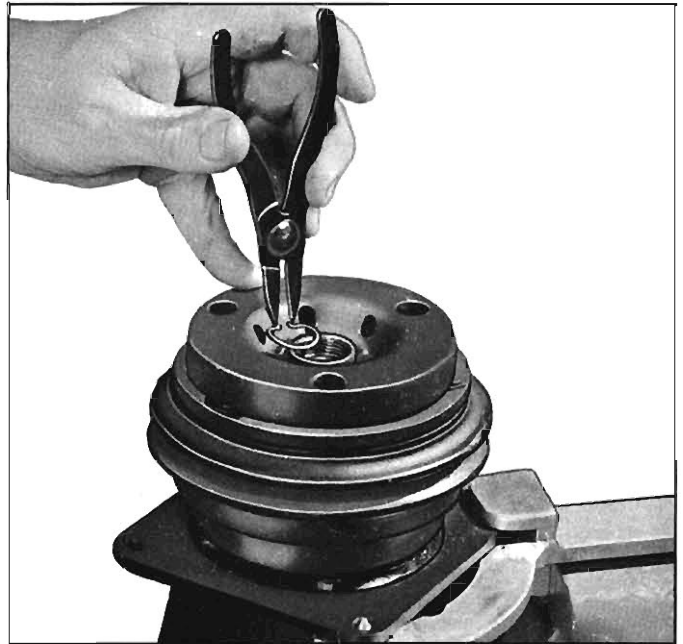

Fig. 11-35—Removing Pulley and Bearing Assembly Retainer Ring

Pulley and Bearing Assembly

Removal

1. Remove the hub and drive plate assembly.
2. Using snap ring pliers J-6435, remove the pulley and bearing retainer ring (fig. 11-35).
3. Remove shaft key.
4. Replace puller pilot J-9395 over the compressor shaft and pull off the pulley assembly using J-8433 pulley puller with long puller legs J-9405-1 (fig. 11-36).

Inspection

Check the appearance of the pulley and bearing assembly. If the frictional surface of the pulley shows signs of workage due to excessive heat, the pulley should be replaced. If the pulley bearing shows signs of excessive looseness, noise or grease leakage, it should be replaced. The frictional surfaces of the bearing to be used should be cleaned with a suitable solvent before reinstallation.

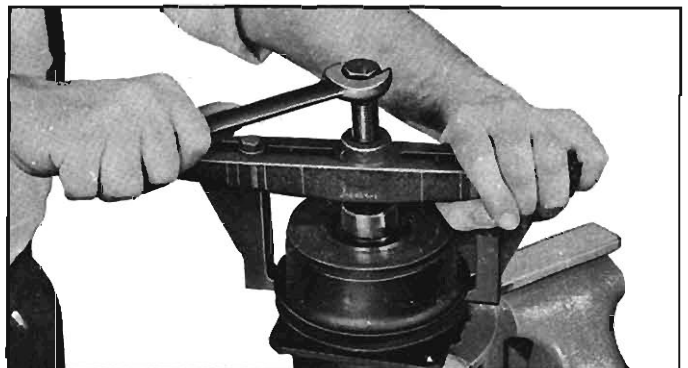

Fig. 11-36—Removing Pulley



Fig. 11-37—Removing Coil Housing Retainer Ring

Bearing Replacement

1. With the pulley and bearing assembly removed from the compressor, use a sharp pointed instrument to remove the wire retainer ring.
2. From the rear of the pulley, press or drive bearing out of pulley using Tool J-9398 and handle J-8092.
3. Wipe excess grease from the new bearing.
4. From the front of the pulley and using Tool J-9481 with handle J-8092, press or drive the new bearing into the pulley.

Installation

1. Using Tool J-9481, press or drive the pulley and bearing assembly onto the compressor neck. The pulley should now rotate freely.
2. Install retainer ring using snap ring pliers J-6435.
3. Replace the hub and drive plate assembly. Use proper tools. **DO NOT** drive or pound on the hub assembly.
4. Install the wire bearing retainer ring.

Coil Housing Assembly

Removal

1. Remove the hub and drive plate assembly, the pulley and bearing assembly, and electrical connector.
2. Scribe the location of the coil housing to the compressor body. This operation is to insure that the

electrical terminals will be reassembled in the same position.

3. Using snap ring pliers J-6435, remove the coil housing retainer ring (fig. 11-37).
4. Remove the coil housing assembly.

Inspection

Check coil for loose connectors or cracked insulation. Amperage should not be more than 3.2 amps at 12 volts D.C. at room temperature.

Installation

1. Rotate the coil housing to the correct position as indicated by the scribe marks and the location of the electrical terminals and fit into place. (fig. 11-38).

2. Use snap ring pliers J-6435 to install retainer ring.

NOTE: Install flat surface of the retainer ring facing the coil housing.

3. Replace the pulley and bearing assembly and the hub and drive plate assembly. **DO NOT** drive or pound on the hub assembly.

4. If the compressor is installed in the vehicle, connect the electrical connections.

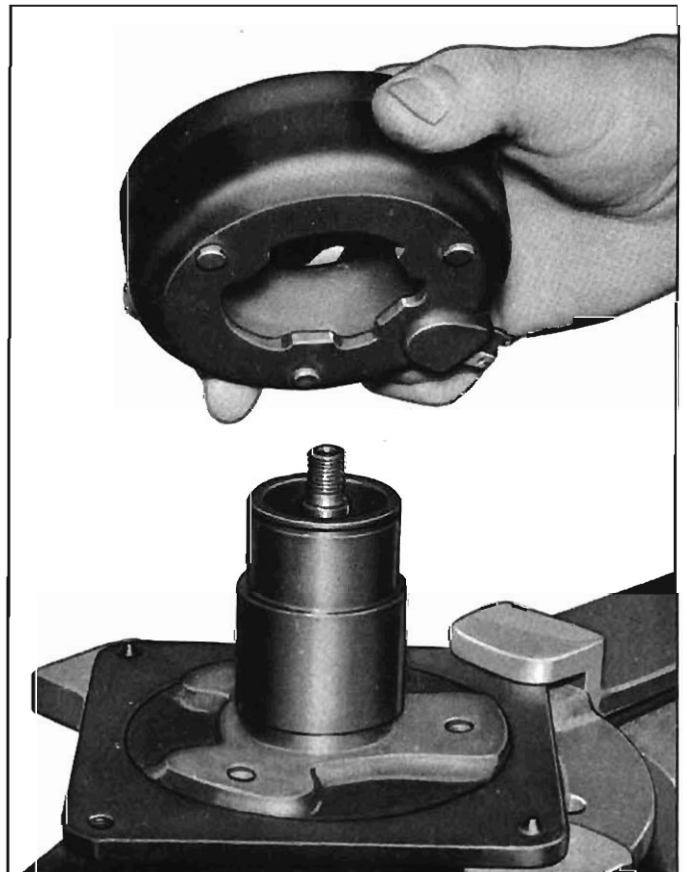

Fig. 11-38—Installing Coil Housing

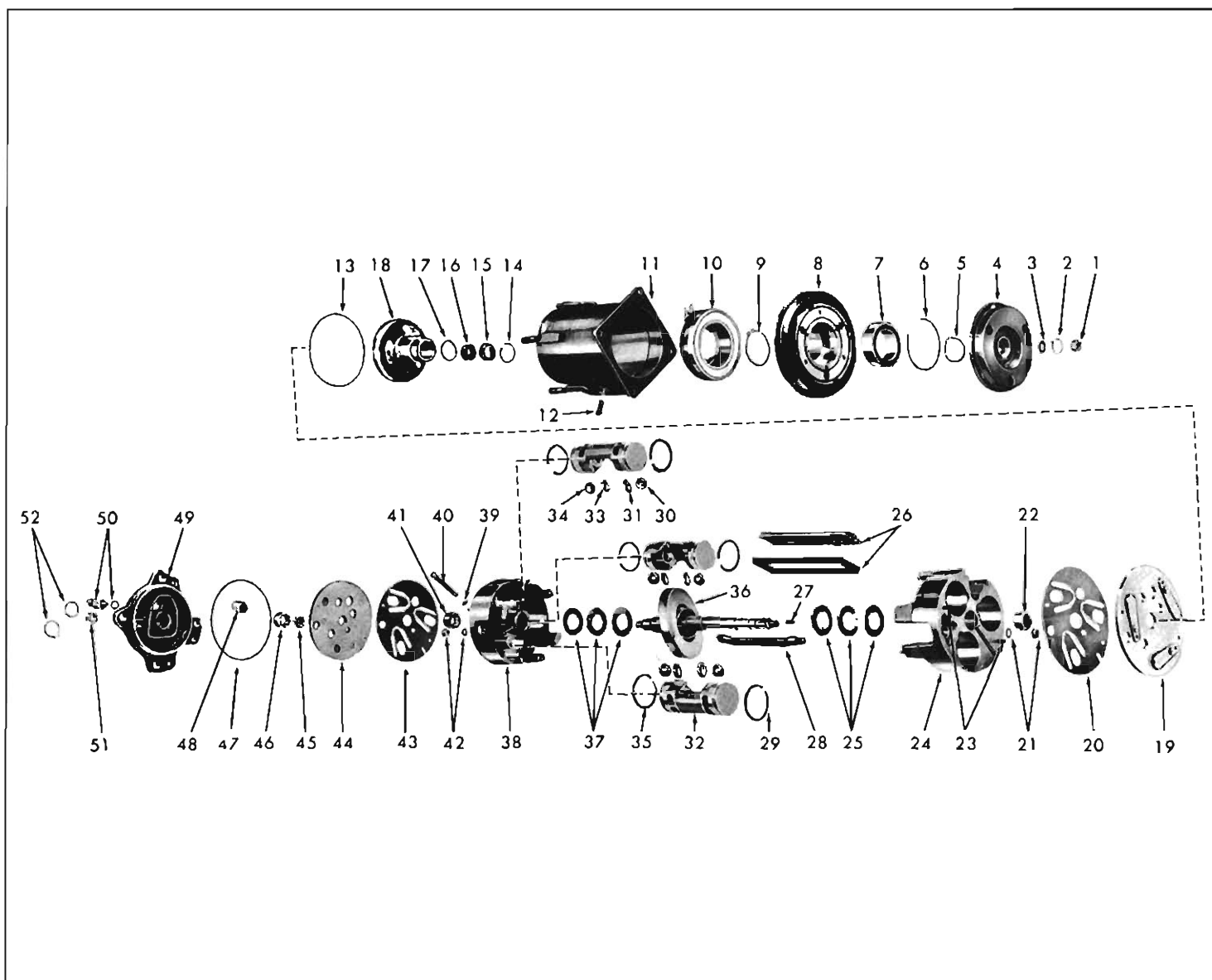

Fig. 11-39—Six Cylinder Compressor—Exploded View

- | | | |
|--|--|---|
| 1. Shaft Nut | 19. Front Discharge Valve Plate | 36. Drive Shaft and Wobble Plate Assembly |
| 2. Clutch Hub Retainer Ring | 20. Front Suction Reed Valve | 37. Rear Thrust Race and Bearing Pack |
| 3. Spacer | 21. Discharge Crossover Tube Front "O" Ring and Spacer | 38. Rear Cylinder Half |
| 4. Clutch Hub and Drive Plate Assembly | 22. Mainshaft Front Bearing | 39. Oil Inlet Tube "O" Ring |
| 5. Pulley and Bearing Retainer Ring | 23. Head Locating Pins | 40. Oil Inlet Tube |
| 6. Pulley Bearing Retainer Ring | 24. Front Cylinder Half | 41. Mainshaft Rear Bearing |
| 7. Pulley Bearing | 25. Front Thrust Race and Bearing Pack | 42. Discharge Crossover Tube Rear "O" Ring and Spacer |
| 8. Pulley | 26. Suction Crossover Cover and Gasket | 43. Rear Suction Reed Plate |
| 9. Coil Housing Retainer Ring | 27. Drive Key | 44. Rear Discharge Valve Plate |
| 10. Coil Housing | 28. Discharge Crossover Tube | 45. Oil Pump Drive Gear |
| 11. Compressor Shell | 29. Piston Ring | 46. Oil Pump Driven Gear |
| 12. Oil Drain Plug | 30. Piston Front Drive Ball | 47. Rear Head-to-Shell "O" Ring |
| 13. Front Head-to-Shell "O" Ring | 31. Piston Front Ball Seat | 48. Strainer Screen |
| 14. Shaft Seal Seat Retainer Ring | 32. Piston | 49. Compressor Rear Head |
| 15. Shaft Seal Seat | 33. Piston Rear Ball Seat | 50. High Pressure Relief Valve and "O" Ring |
| 16. Shaft Seal | 34. Piston Rear Drive Ball | 51. Rear Head-to-Shell Retaining Nuts |
| 17. Shaft Seal Seat "O" Ring | 35. Piston Ring | 52. Compressor-to-Connector "O" Rings |

MAJOR SERVICE OPERATIONS

The following service procedures are considered major since the refrigeration system must be completely purged of refrigerant before proceeding and because major internal operating and sealing components of the compressor are being disassembled and serviced. A clean workbench, preferably covered with a sheet of clean paper, orderliness in the work area and a place for all parts being removed and replaced is of great importance as is the use of the proper service tools. Any attempt to use make-shift or inadequate equipment may result in damage and/or improper compressor operation.

These procedures are based on the use of the proper service tools and the condition that an adequate stock of service parts is available. This service parts stock should include the following:

1. Major interior mechanism assembly—ready for installation in shell as is.
2. Service cylinder assembly—front and rear halves with main bearings in place and halves dowel pinned together.
3. Standard size piston drive balls.
4. Ball seats—total of 10 sizes, including the ZERO shoe.
5. Thrust races—total of 14 sizes, including the ZERO race.
6. Pistons.
7. Main shaft bearings.
8. Thrust bearings.
9. Compressor shaft, wobble plate and Woodruff key assembly.
10. Suction reed valves.
11. Discharge valve plate—front and rear.
12. Gasket kit—service—contains all seals and "O" rings. To be used each time a compressor is rebuilt.
13. Shaft seal kit.
14. Nuts—head to shell, and shaft.
15. Retainer rings—all necessary sizes.
16. Cylinder locator (dowel) pins.
17. Valve and head locator (dowel) pins.
18. Service discharge crossover tube kit.

All parts required for servicing are protected by a preservation process and packaged in a manner which will eliminate the necessity of cleaning, washing or flushing of the parts. The parts can be used in the mechanism assembly just as they are removed from the service package.

Piston ball seats and shaft thrust races will be identified on the parts themselves to denote their size and dimension.

Shaft Seal Assembly

When replacing the shaft seal assembly, even if the compressor remains on the vehicle during the opera-



Fig. 11-40—Removing Seal Seat Retaining Snap Ring

tion, it will be necessary to purge the system of refrigerant.

Removal

1. After first purging the system of refrigerant, remove the clutch hub and drive plate, and the shaft key.
2. Remove the seal seat retaining ring using snap ring pliers J-5403 (fig. 11-40).
3. Using Tool J-9393 (1 and 2), grasp the flange on the seal seat and lift out the seal seat (fig. 11-41).

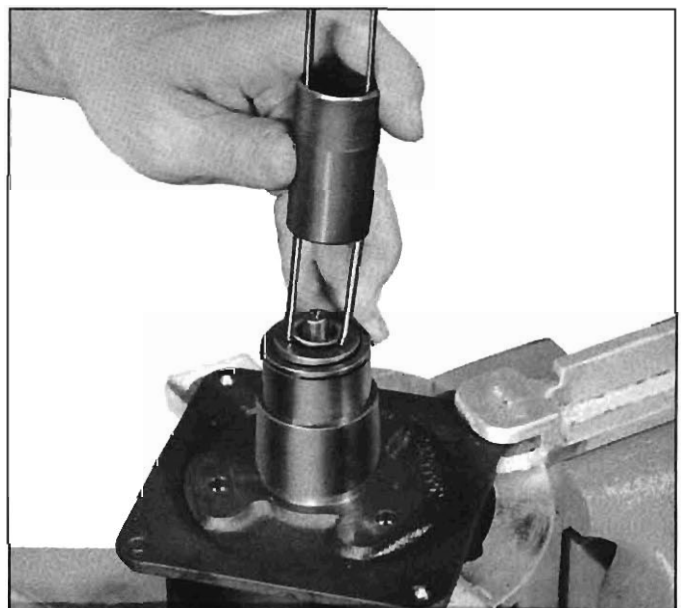

Fig. 11-41—Removing Seal Seat

4. Remove the seal seat "O" ring from the housing bore using Tool J-5139.
5. Engage the tabs on the seal assembly with the locking tangs on Tool J-9392 by pressing down and twisting the tool, then lift the seal out.

Inspection

Check the face of the seal for nicks, gouges or serrations. If damage of any kind is evident, replace the seal. Be extremely careful that the face of the seal which is to be installed is not scratched or damaged in any way.

Installation

1. Engage seal onto the locking tangs of Tool J-9392 (fig. 11-42) and carefully insert the seal and tool over the end of the shaft. Turn seal to engage the flat on the shaft, then remove the tool.

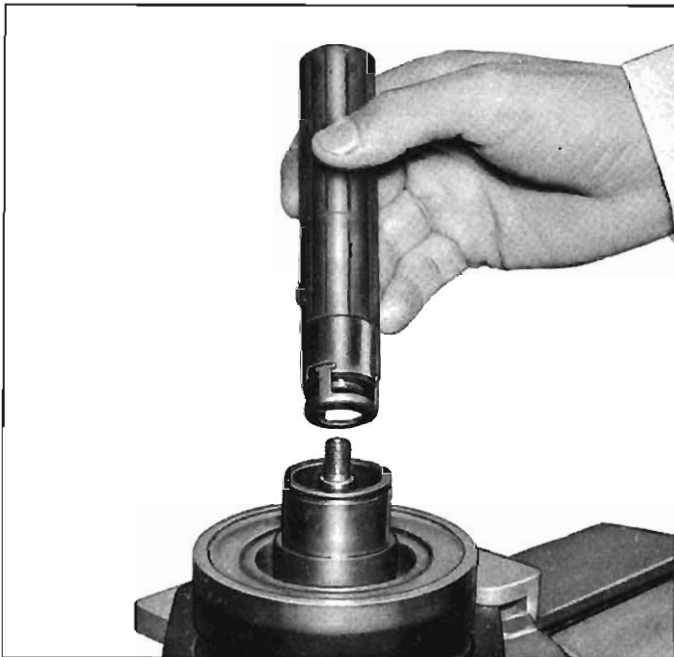

Fig. 11-42—Replacing Seal

2. Coat a new "O" ring and the interior of the seal cavity, shaft and seal with clean refrigeration oil and install it in its groove just above the seal.
3. Using Tool J-9393, grasp the seal seat and set in place on top of the seal.
4. Using snap ring pliers J-5403, replace the retaining ring.

NOTE: Install the retaining ring with the flat surface facing away from the seal seat.

5. Leak test the compressor as described under "Leak Testing the Compressor" in this section.
6. Reinstall the clutch hub and drive plate.
7. Replace the compressor on the vehicle, if it was previously removed, and evacuate and charge the system.

Pressure Relief Valve

When a faulty pressure relief valve, located in the rear head casting, is encountered, the valve assembly should be removed after purging the system and a new valve and gasket installed. The entire system should then be evacuated and recharged.

Compressor Rear Head and Internal Mechanism

Service operations to the rear head or internal mechanism of the compressor should be performed with the compressor removed from the vehicle to insure that the necessary degree of cleanliness may be maintained. Clean hands and a clean bench, preferably covered with clean paper, are of extreme importance.

Rear Head, Oil Pump and Valve Assemblies

Removal

1. Remove the compressor from the vehicle, drain compressor oil into a clean container, clean the exterior of the compressor case and rear head casting with a suitable solvent and mount the compressor, rear head up, in holding fixture J-9396 which should then be mounted securely in a vise.
2. Remove the four nuts from the shell studs. Discard nuts.
3. Remove the rear head. Examine the teflon surface on the casting webs. If this surface is damaged by nicks or scratches, the head should be replaced.
4. Examine the suction screen in the rear head for any damage or contamination. Clean or replace the screen as necessary.
5. Remove and examine the oil pump gears. If either of the gears shows any wear or damage, replace both gears.

NOTE: Keep the ends of the two oil pump gears matched and replace the same end toward the discharge plate upon reassembly.

6. Remove the rear head-to-shell "O" ring and discard.
7. With two screwdrivers, carefully pry up on the rear discharge valve plate assembly (fig. 11-43). Check for broken reeds or damaged seats and replace entire assembly if such is found.

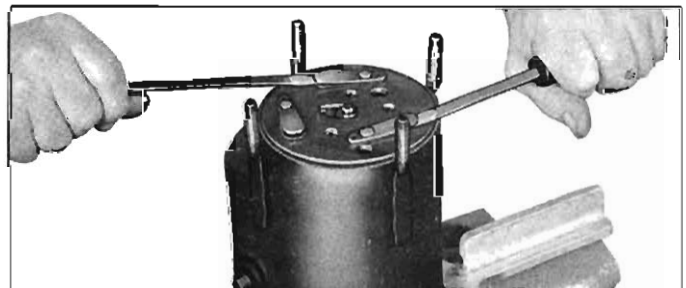

Fig. 11-43—Remove Rear Discharge Valve Plate

8. Carefully lift off the rear suction reed valve. Valve must be replaced if any damage is evident.

Installation

1. Carefully replace the suction reed valve and the rear discharge plate over the dowel pins and ports in the cylinder assembly.
2. Position the rear head casting to align with the dowel pins. The two lower mounting pads will be in alignment with the oil sump in the shell. Rotate the cylinder assembly back and forth by hand, if necessary, to permit this alignment. Remove the rear head from this trial assembly.
3. Install the inner oil pump gear over the "D" flat on the shaft and place the outer oil pump gear over the inner gear. Position the outer gear as follows:
 - a. Observe the position of the oil sump in the shell.
 - b. Locate the approximate centerline of this sump.
 - c. Facing the centerline of the sump and viewing from the sump side (bottom) of the compressor, move the OUTER gear toward the LEFT (side opposite the oil test fitting) until it is at approximately 90° (9 o'clock position) from the centerline of the oil sump (fig. 11-44).
4. Coat the head-to-shell "O" ring with clean refrigeration oil and generously lubricate the area around the outer edge of the valve plate where



Fig. 11-44—Proper Oil Pump Gear Positioning

the "O" ring will be placed. Oil also the oil pump gears, valve reeds and the area where the teflon gasket will contact the valve plate.

5. Install the head-to-shell "O" ring.
6. Be sure that the suction screen is properly positioned in the rear head, then assemble the rear head to the compressor shell being carefully not to damage the teflon gasket.

NOTE: As an aid to replacing the head in the proper position, be sure the inlet and outlet ports are toward the top of the compressor.

CAUTION: Be sure head does not bind against oil pump gears when being installed.

7. Install new nuts to the threaded shell studs and tighten to 19-23 ft. lbs. torque.
8. Leak test the compressor as outlined under "Leak Testing the Compressor" in this section.
9. Install compressor as described under "Compressor—Installation."

MAJOR INTERNAL MECHANISM

Removal from Shell

1. Remove the rear head, discharge plate and suction reed from the compressor as outlined under "Rear Head and Reed Assemblies" above.
2. Remove the oil inlet tube and "O" ring with J-5139 as shown in Fig. 11-45.
3. Carefully lay the compressor shell on its side and slide out interior mechanism and front head assembly. Do not hammer or use undue force to remove the mechanism, however, gentle taps on the head casting may aid in removing the assembly.

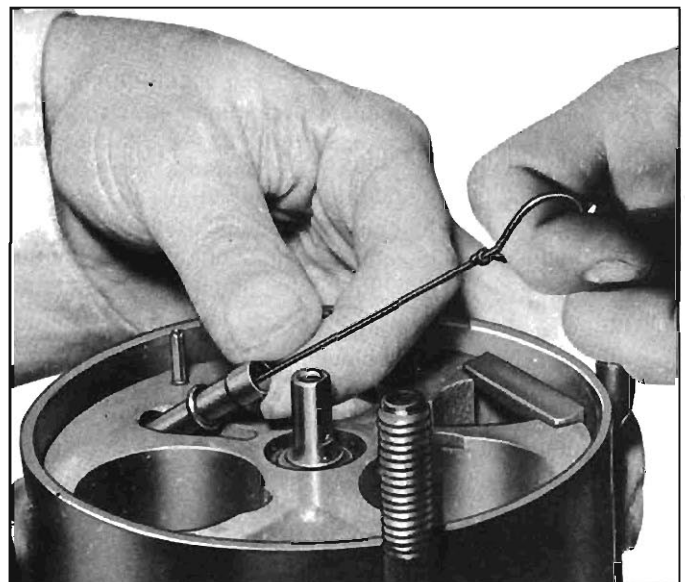

Fig. 11-45—Removing Oil Inlet Tube and "O" Ring

ACCESSORIES 11-34

4. Remove front head casting, front discharge valve plate and suction reed valve from the mechanism. Examine parts for damage and replace if necessary. Check particularly for damage to the teflon surfaces on the front head casting webs.
5. Examine the mechanism for any obvious damage.
6. Remove the suction crossover cover (fig. 11-46) and discard the old gasket.

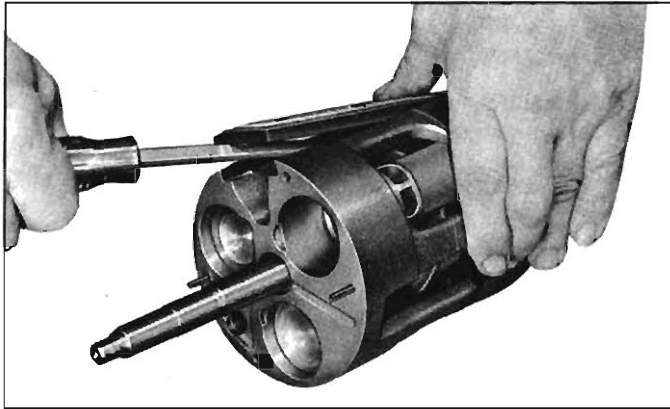

Fig. 11-46—Removing Suction Crossover Cover

7. If desired, the mechanism may be assembled in checking cage J-9397 and operated on a motor test stand, or by some other suitable means, to observe sound level and general operation. Tighten cage nuts evenly to 15 ft. lbs. torque.
8. While in the checking cage, make a check of the shoe clearances between each rear piston shoe and the swash plate (reading must be between .0005"-.0010"). Check also the clearance between the rear thrust race and rear thrust bearing. (Maximum clearance should be .0015".) These checks may give some indication of the cause of the trouble.
9. Remove mechanism from the cage.

Disassembly

If the mechanism has sustained major damage, due possibly to loss of refrigerant and/or oil, it may be necessary to replace it with a complete service interior mechanism assembly rather than to replace individual parts. If further disassembly is considered worthwhile, proceed as follows:

1. Before disassembling the cylinder and mechanism, number the pistons and cylinder locations so that all parts may be replaced in their original location. Pistons and cylinder bores may be identified by numbering them 1, 2 and 3 with a pencil.
2. Use J-9492 to drive discharge tube out of cylinder fig. 11-47. (Drive toward REAR of cylinder.)
3. Drive the cylinder halves apart and free from the dowel pins and discharge crossover tube using a fiber block and mallet (fig. 11-48). Discard the discharge crossover tube.

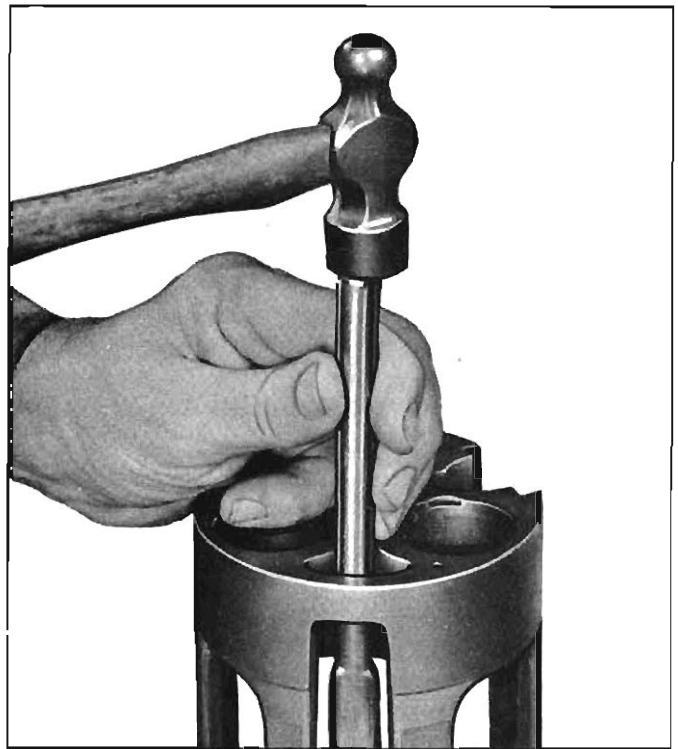

Fig. 11-47—Unseating Discharge Crossover Tube

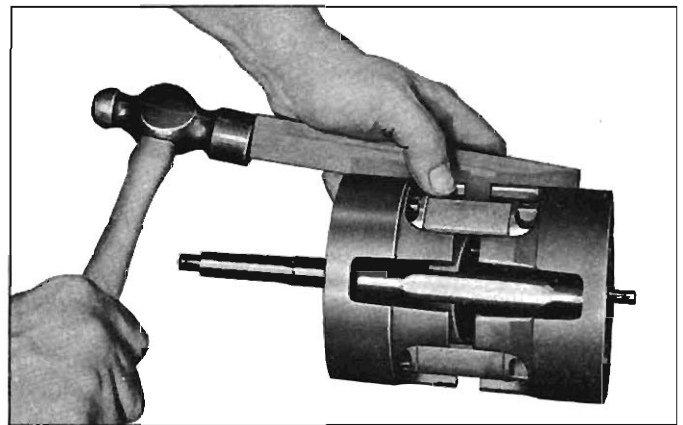

Fig. 11-48—Separating Cylinder Halves

NOTE: Before driving cylinder apart, position swash plate so low part is under crossover tube toward rear of cylinder assembly.

4. Carefully remove the rear half of the cylinder from the pistons and set the front cylinder half, with the pistons, shaft and wobble plate, in J-9397.
5. Push up on the shaft and, one assembly at a time, remove pistons, rings, seats and balls placing all parts in tray J-9402 in the compartment associated with the proper end of the pistons. Discard all piston ball seats.

NOTE: The front of the piston may be identified by a notch in the casting web. See Fig. 11-49. The piston compartments in Tray J-9402 have a boss at this notch location to indicate the front.

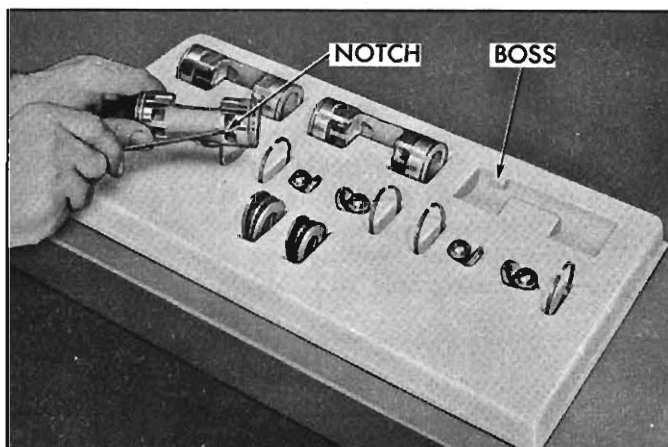

Fig. 11-49—Notch Identifying Front End of Piston

6. Remove and inspect all piston rings. Replace all broken or damaged rings. Damaged pistons must also be replaced.
7. Examine piston balls. Replace if they show burning or excessive wear.
8. Remove the rear combination of thrust races and bearing from the shaft and discard all three pieces.
9. Remove the shaft and wobble plate assembly from the front half of the cylinder.
10. Remove the front combination of thrust washers and bearing and discard all three pieces.
11. Examine all surfaces of the wobble plate and, if satisfactory, reuse. If it shows signs of excessive wear, replace the shaft and wobble plate as an assembly. Use care not to move wobble plate on the shaft. This is factory set.
12. Examine the front and rear cylinder halves and replace if cylinder bores are deeply scored or damaged.
13. Wash all parts to be reused in a suitable cleaner. Blow dry all parts.
14. If cylinder main bearings are to be replaced, they may be removed and reinstalled at this time using Tool J-9432.

Gauging Procedure

The gauging operations which follow have been worked out on a simple basis to establish and provide necessary running clearances. Two gauging procedures are necessary.

The first gauging operation is made to choose the proper size shoe discs to provide, at each piston, a .0005" to .0010" total clearance between the seats and the wobble plate at the *tightest* place through the 360° rotation of the wobble plate. Ten bronze ball seats are

provided in .0005" variations including a basic ZERO seat.

The second gauging operation, performed at the rear shaft thrust bearing and race pack, is designed to obtain .0005" to .0015" running clearance between the hub surfaces of the wobble plate and the front and rear hubs of the cylinder. A total of 14 steel thrust races, including a basic ZERO race, are provided in increments of .0005" thickness to provide the required clearance.

Proper selection of thrust races and shoe discs is of extreme importance. If tolerance is *greater* than maximum clearance, noisy operation of the compressor will result while tolerance *less* than minimum clearance could result in galling and seizure of the parts.

1. Secure from service parts stock:
 - Four-ZERO thrust races
 - Three-ZERO ball seats
 - Two-New thrust bearings
2. Assemble a ZERO thrust race, a new needle thrust bearing and another ZERO thrust race, in that order, to the front end of the shaft. (A dab of petroleum jelly will hold the bearing-race pack together and in place on the shaft.) Lubricate front and rear faces of the wobble plate with refrigeration oil.
3. With the front half of the cylinder assembly resting on Tool J-9397, insert the shaft, threaded end through the main bearing until the thrust race assembly rests on the front cylinder hub.
4. Assemble a ZERO thrust race, a new needle bearing and a second ZERO thrust race in that order, to the rear of the shaft.
5. Apply a *light* smear of clean petroleum jelly to the ball pockets of each of the three pistons.
6. Place the balls in the piston pockets. The petroleum jelly will hold the balls in place.
7. Apply a *light* smear of petroleum jelly to the cavity of three new ZERO ball seats and place one shoe over each front piston ball. There should now be a ball and seat in the front ball pocket of each piston and a ball only in the rear ball pocket.

NOTE: Do not assemble any of the piston rings at this time.

8. Rotate the shaft and wobble plate until the high point of the wobble plate is directly over the cylinder bore previously designated as No. 1. Lift up slightly on the shaft and wobble plate assembly, insert the front (notched) end of the No. 1 piston into the cylinder bore, and at the same time, place the front ball and seat and the rear ball only over the wobble plate (fig. 11-50). Hold front thrust bearing pack tight against wobble plate hub while lifting shaft.
9. Repeat this operation with pistons No. 2 and No. 3.
10. Align the rear head casting with bores, suction

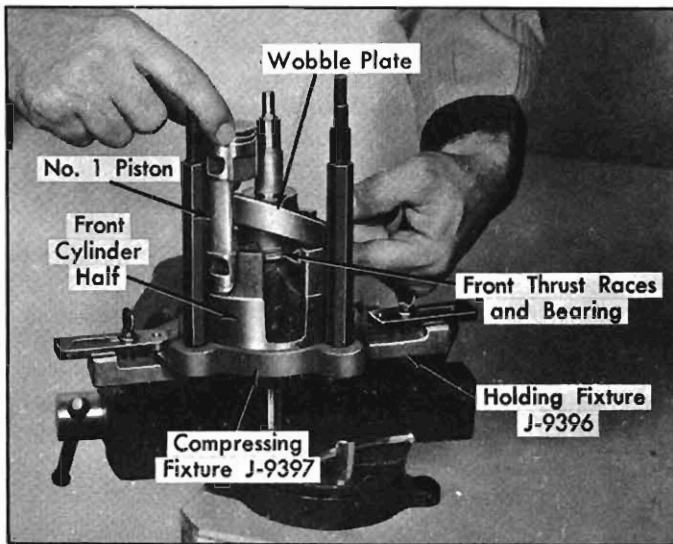

Fig. 11-50—Installing Piston Over Wobble Plate

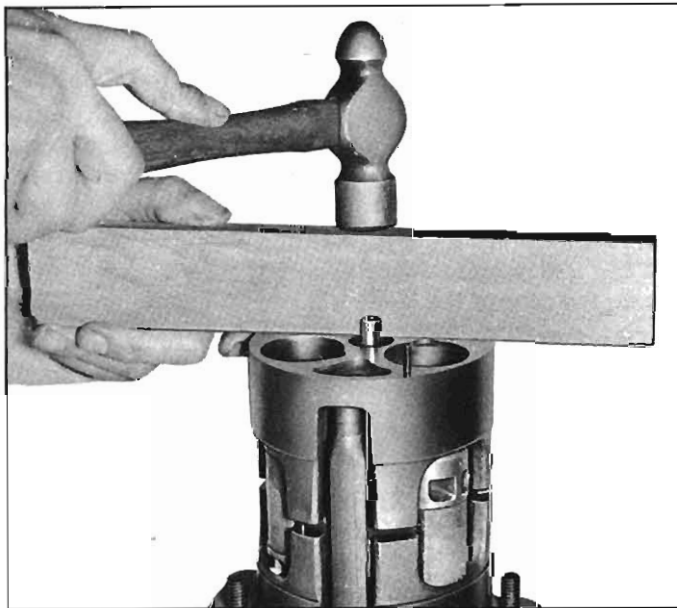

Fig. 11-51—Assembling Cylinder Halves

passage, discharge cross-over holes, and dowel pins. Tap into place, using a plastic block and mallet (fig. 11-51).

11. Place the cylinder assembly in the checking cage with the front of the compressor shaft pointing up, positioning the discharge tube opening between the cage bolts. This will provide access for the feeler gauge. Assemble the cage and tighten all nuts evenly to 19-23 ft. lbs.
12. Use a leaf type feeler gauge and a suitable spring scale to check clearance between the REAR ball and the wobble plate (fig. 11-52) of the No. 1 piston. Use a suitable combination of feeler gauge

leaves until 4 to 8 oz. of force is required to pull gauge from between the ball and the plate.

NOTE: Use undamaged feeler gauges generously lubricated with refrigeration oil. Support the spring scale so that only the actual force required to pull the feeler gauge free is measured.

Rotate the shaft approximately 120° and again check with a feeler gauge between the parts. Rotate the shaft another 120° and make a third check. From this total of three feeler gauge checks, use the MINIMUM reading to select a numbered shoe to correspond to the feeler gauge reading (i.e.—if minimum reading was .019, use a No. 19 shoe. If reading was .0195, use a No. 19½ shoe.)

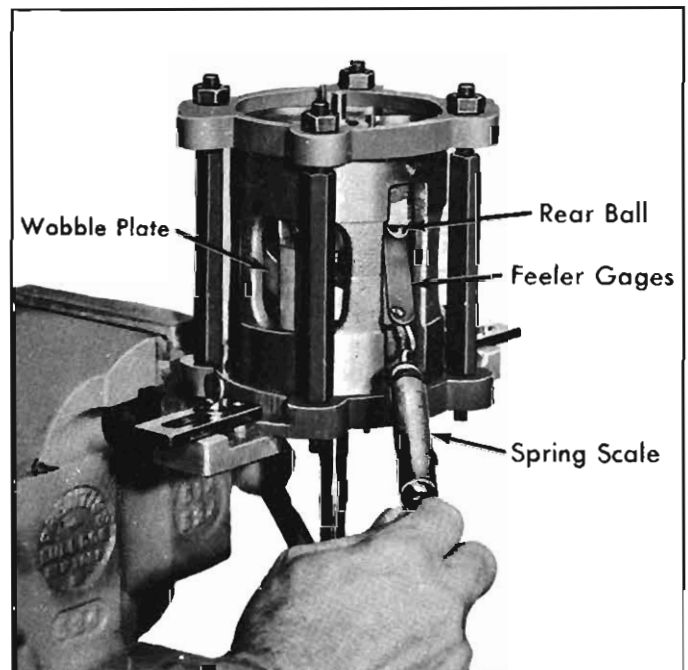

Fig. 11-52—Checking Clearance Between Rear Ball and Wobble Plate

Place this shoe in the parts tray in the compartment corresponding to the rear ball position of the No. 1 piston.

13. Repeat the operation described in Step 12 for pistons No. 2 and No. 3.
14. The next gauging operation is to determine the space between the REAR thrust bearing and the upper (outer) rear thrust race. Use a suitable combination of feeler gauge leaves so that 4 to 8 oz. of force is required to pull gauge free (fig. 11-53). Select a numbered thrust race to correspond to this feeler gauge reading and place this race in parts tray in the rear thrust race compartment.
15. Loosen the nuts and ring from the checking cage.
16. Drive the cylinder halves apart, using a fiber block and mallet.
17. Carefully remove the rear half of the cylinder and

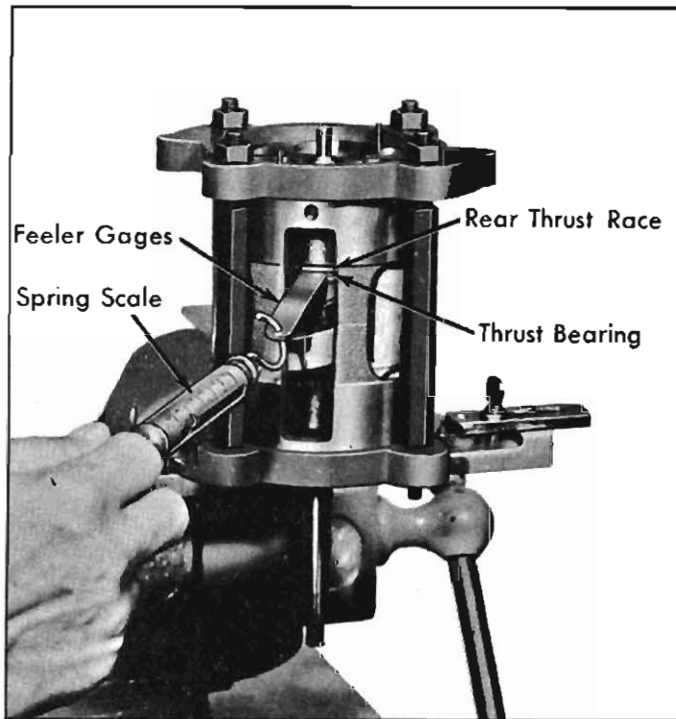

Fig. 11-53—Checking Clearance Between Rear Thrust Bearing and Outer Thrust Race

set the front half (including the pistons and shaft and wobble plate assembly) on J-9397.

18. Carefully remove one piston at a time from the wobble plate and the front half of the cylinder. Transfer each piston, ball and seat to its proper place in the parts tray along with the numbered rear shoe chosen in Steps 12 and 13 above.

CAUTION: When the balls and seats are removed from the piston, be sure that they are placed in the proper parts tray pocket so as not to lose the relationship of the balls and seats to the proper end of the piston.

19. Remove the rear upper (outer) ZERO thrust race from the compressor shaft and replace it with the numbered thrust race (determined in Step 14 above) from the parts tray.

NOTE: This ZERO thrust race may be put aside for reuse in future gauging and/or rebuild operations.

20. The gauging operations are now complete.

Assembly

After properly performing the gauging procedure and choosing the correct ball seats and thrust races as outlined under "Gauging Procedures," the cylinder assembly may be reassembled. Be sure to install all

new seals and "O" rings. All are included in the compressor seal service kit.

1. Support the front half of the cylinder assembly on fixture J-9397 and install the shaft and wobble plate, threaded end down, with its front bearing race pack (ZERO race, bearing and ZERO race) and its rear bearing race pack (ZERO race, bearing, numbered race) if this was not already done at the end of the "Gauging Procedure."
2. Assemble a piston ring, scraper groove toward the center of the piston, to each end of the three pistons.
3. Apply a *light* smear of petroleum jelly to the numbered ball seats chosen in the gauging procedure and install all balls and seats (if removed in Step 18 of the gauging procedure) in their proper place in the piston.
4. Rotate the wobble plate so that the high point is above cylinder bore No. 1. Carefully assemble piston No. 1, complete with ball and ZERO seat on the front and ball and numbered seat on the rear, over the swash plate. Hold front thrust bearing pack tight against wobble plate hub while lifting hub. Compress and enter the piston ring into the front cylinder half.
5. Repeat this operation for pistons No. 2 and No. 3.
6. Assemble one end of a *service* discharge crossover tube into the hole in the front cylinder half.
7. Rotate the shaft to position the pistons in a stair-step arrangement, then carefully place the rear cylinder half over the shaft and start the pistons into the cylinder bores.
8. Compress the piston ring on each piston to permit its entrance into the cylinder.
9. When all three pistons and rings are in their respective cylinders, align the end of the discharge crossover tube with the hole in the rear half of the cylinder.

NOTE: Be sure the flattened portion of this tube faces the inside of the compressor to allow for swash plate clearance.

10. When all parts are in proper alignment, tap with a fiber block and mallet to seat the rear half of the cylinder over the locating dowel pins. If necessary, clamp the cylinder in J-9397 to complete drawing the cylinder halves together.
11. Generously lubricate all moving parts with clean refrigeration oil and check for free rotation of the parts.

NOTE: It may be desirable to clamp the cylinder assembly in compressing fixture J-9397 and check on the motor test stand for proper operation before proceeding further. If any improper operation is observed, the mechan-

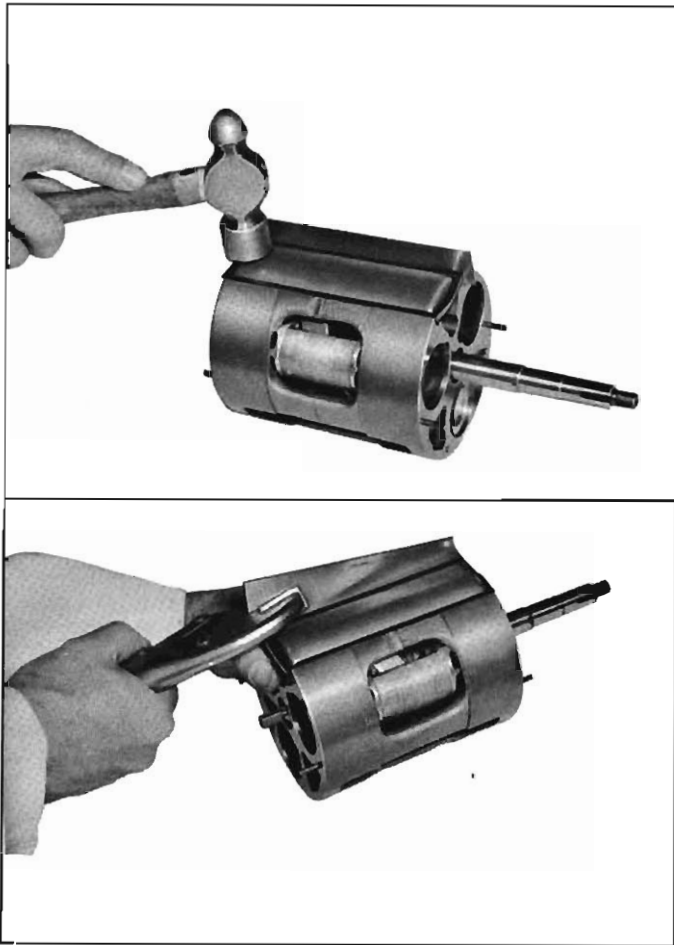

Fig. 11-54—Installing Suction Crossover Cover

11-54) and press or tap the cover into place. Remove the piece of sheet metal with a pair of vice grip pliers, using a “prying-up” motion, with the pliers resting on the cover to retain it in the slots. Be sure cover and gasket are properly seated. The cylinder assembly is now complete.

Installation Into Shell

1. Support the cylinder on fixture J-9521 with the threaded end of the shaft up.
2. Assemble the two dowel pins in the front cylinder if they are not already in place.
NOTE: A rod drilled 1/4" deep to the O.D. of the dowel pins will aid in installing.
3. Install the discharge crossover tube front “O” ring and spacer (fig. 11-55).
4. Aligning the dowel pin holes, discharge crossover hole and oil return slot, assemble the suction reed valve to the front end of the cylinder.
5. Assemble the front discharge valve plate, aligning the holes with the dowel pins and proper openings in the head.
NOTE: The front discharge plate has a larger diameter hole in the center than the rear discharge plate.
6. Check the teflon surface on the compressor front

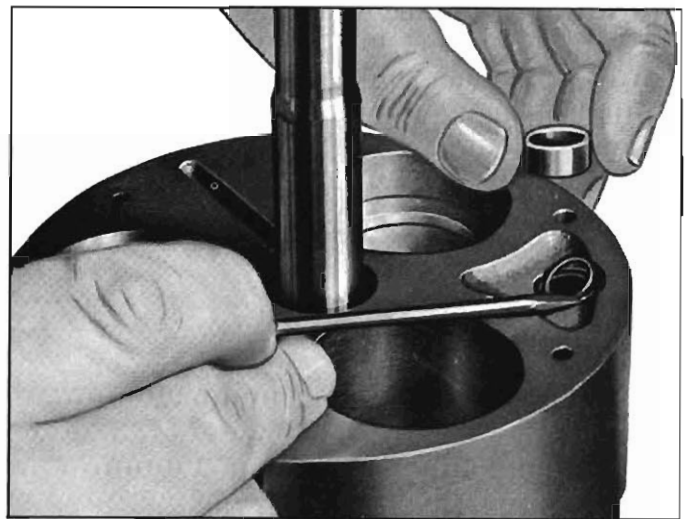

Fig. 11-55—Installing Discharge Crossover Tube Front “O” Ring and Spacer

head casting webs and replace the entire casting if there is any evidence of damage. Discard the “O” ring.

7. Coat the valve plate with clean refrigeration oil. Rotate the front head casting until it is properly positioned over the discharge reed retainers and dowel pins, then set it in place (being careful not to damage the teflon surfaces) and seat it over dowels with light mallet taps.

NOTE: Dowel pin and hole location can be marked with pencil to aid in locating proper position.

8. Apply clean refrigeration oil to a new “O” ring and “O” ring groove at the lower edge of the front head casting and carefully assemble the “O” ring in the groove.
9. Coat the inside machined surfaces of the compressor shell with refrigeration oil.
10. Locate the oil intake tube hole in the rear discharge plate. Line up the oil sump with this hole location and slide the shell down over the mechanism while supporting the mechanism on J-9521 (fig. 11-56).
11. Place compressor support bracket J-9396 in a vise and, carefully inverting the compressor case with the mechanism inside, mount the front compressor flange on the support bracket.
12. Place a new “O” ring in the oil intake tube hole applying clean refrigeration oil to the oil intake tube hole and the “O” ring. Rotating the compressor mechanism to line up with the hole in the compressor case baffle, install the oil pickup tube. Be sure that the “O” ring and intake tube are properly seated.
13. Assemble the dowel pins into the rear cylinder.
14. Install the discharge crossover tube rear “O” ring and spacer.



Fig. 11-56—Installing Shell Over Internal Mechanism

ism should be regauged to insure proper operation. Complete the assembly procedure when correct operation is obtained.

12. Assemble a new rectangular gasket to the suction crossover cover. Coat the gasket with clean refrigeration oil. Start one side of the gasket and cover into the "dove tail" slot in the cylinder, centering the gasket and cover with the ends of the cylinder faces. Use Tool J-9433 or a flat piece of spring steel (.015" to .020" thickness) as a shoe horn (fig. 11-56).
15. Replace the rear suction reed valve, rear discharge valve plate, oil pump gears, rear head and head nuts as outlined previously under "Rear Head and Reed Assemblies—Installation."

LEAK TESTING THE COMPRESSOR

Whenever service operations are performed on the compressor shaft seal assembly or on the interior mechanism, use the following procedure to leak test the reassembled compressor.

1. Install "O" rings and cover plate J-9527 over the

suction and discharge ports on the compressor head.

2. Hook up a Freon-12 container and charging line using adapter J-5420) to cover plate fitting over the suction port, charge the compressor up to can pressure, and leak test compressor with a leak detector.
3. Turn off the Freon container valve, transfer gauge line and adapter to cover plate fitting over the discharge port and repeat the procedure outlined in Step 2.
4. Correct any leaks present.

COMPRESSOR BELT TENSION ADJUSTMENT

Adjust compressor belt tension to give $\frac{1}{2}$ " to $\frac{3}{4}$ " deflection under a 15 lb. load, measured midway between the compressor pulley and the crankshaft pulley.

CONDENSER

Replacement

1. Purge the system of refrigerant.
2. Remove the two refrigerant lines from the condenser and cap the lines immediately.
3. Remove screw attaching clip and hoses to condenser.
4. Remove the three screws on each side of the condenser which attach the condenser and shroud assembly to the mounting brackets (fig. 11-57).
5. Remove the condenser assembly from the vehicle.
6. All screws attaching the shroud to the condenser core may now be removed and the core detached from the shroud.

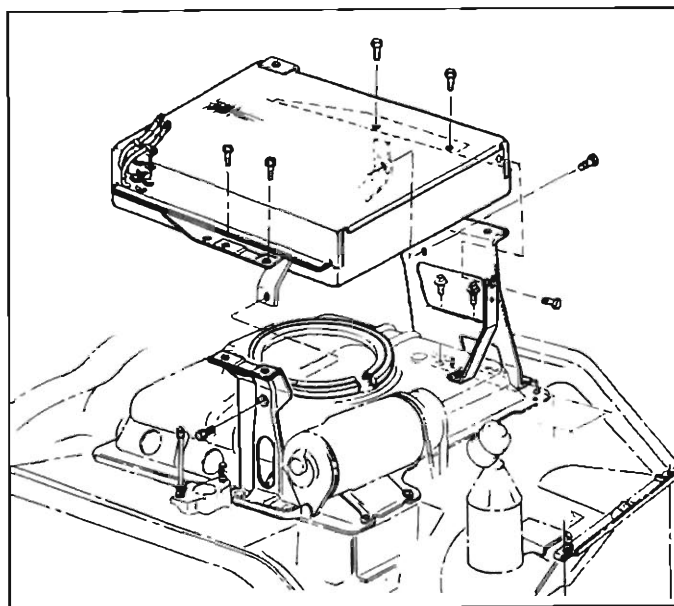

Fig. 11-57—Condenser Removal

ACCESSORIES 11-40

7. Attach the shroud to the new condenser core and install the assembly onto the mounting brackets.
8. Replace the refrigerant hoses.
9. Evacuate and charge the system.

Engine Access Procedure

NOTE: It is not necessary to disconnect refrigerant lines or purge the refrigerant from the system if the condenser and shroud assembly are to be moved only enough to permit access to the engine (for fan belt replacement use the entire procedure which follows; for carburetor adjustment use only Steps 3 through 5.

1. If engine blower belt is to be changed, loosen the compressor bracket bolts and allow compressor to move in toward engine.
 2. Remove the compressor belt.
 3. Remove the six screws attaching the condenser and shroud assembly to the brackets.
 4. Carefully lift the assembly from the engine and rotate it toward right rear of vehicle as far as the refrigerant lines will permit.
Leave the condenser in this position until the engine work is completed, then re-install the condenser assembly on the engine.
- CAUTION:** Do not remove refrigerant lines.
5. Install screws attaching the condenser and shroud assembly to its mounting brackets.
 6. Install the compressor belt and adjust belt tension.

RECEIVER-DEHYDRATOR

The receiver-dehydrator should be replaced if it has been damaged through an accident or if it leaks or becomes restricted or clogged. Do not attempt to repair the receiver-dehydrator.

If at any time when examining the compressor oil, moisture is found or there is an indication of moisture at the expansion valve needle, the receiver-dehydrator should be replaced as follows:

Replacement

1. Purge the system of refrigerant.
 2. Remove refrigerant lines and cap the lines immediately.
 3. Remove the three screws attaching the receiver-dehydrator to the right quarter sheet metal.
 4. Install the new receiver-dehydrator and connect the refrigerant lines.
- NOTE:** Do not uncap the new receiver-dehydrator until the last instant before installation.
5. Evacuate and charge the system.

COLLISION PROCEDURE

Whenever a car equipped with an air conditioning unit is involved in a collision or wreck, it should be

inspected as soon as possible. The extent of damage to any or all of the component parts and the length of time the system has been exposed to the atmosphere will determine the replacement of parts and processing that will be required. The greater the length of time of exposure to the atmosphere, the greater will have been the chances for air, moisture and dirt to have entered and damaged the system. Every case may be entirely different so it is not possible to establish a hard and fast procedure to follow each time. Good judgment must be used to determine what steps should be taken in each specific case.

The following procedure is presented as a guide for use when inspecting a damaged vehicle equipped with air conditioning.

1. Remove the drive belt. Cut belt off if necessary.
2. Visually inspect the condenser, receiver-dehydrator, compressor, mounting brackets, conditioning unit, all connecting lines, and all controls to determine the extent and nature of the damage.
 - a. No repairs, such as soldering, welding or brazing, should be attempted on the condenser because of its construction. If the vapor passages in the horizontal tubes or return bends or manifolds have been damaged in any way, the condenser should be replaced with a new one.
 - b. The receiver-dehydrator should be replaced if there is any evidence of its having sustained either internal damage or a fracture at any of the lines or welded joints or if the system has been exposed to the atmosphere for an undetermined period of time.
 - c. Examine the compressor for any visible external damage.
 - d. The evaporator should be examined for damage and, if necessary removed or replaced or the entire unit processed where damaged or exposed to the atmosphere.
 - e. All connecting lines and flexible hoses should be examined throughout their entire length for damage. If damaged in any manner, replace with new lines.
 - f. Check all controls and connecting wires for damage and replace with new parts where needed.
 - g. Check the clutch pulley for proper operation and freedom from damage.
3. Install gauge set.
4. Purge the system. Pressure should not exceed 3 to 5 pounds.
5. Remove the compressor from mounting and remove the oil test fitting.
6. Pour out the oil into a clean glass container and examine it for any foreign substance such as dirt, water, metal particles, etc. If any of these are present, the compressor and receiver-dehydrator should be replaced and the other system components should be flushed with liquid Freon.

7. If the oil is clean and free of any harmful substance, replace oil with Frigidaire Oil available through Parts Stock.

NOTE: If the system components have been replaced or flushed, replace the full charge of oil. If not, add no more fresh oil than was drained in Step 6.

8. Charge up the compressor to drum or can pressure and leak test the compressor seals prior to installation of compressor. Use a special cover plate that can be fabricated as described under "Compressor Seal Replacement - Installation," Step 10.
9. Reinstall the compressor and evacuate the system by following the Evacuating Procedure.
10. Introduce Freon-12 vapor at cylinder (room) temperature and pressure.
11. Leak test all fittings and connections and give particular attention to a leak test at the compressor shaft seal if compressor has not been leak tested on the bench.
12. Complete system processing and charge system.

Flushing the System

To flush the components of the system with liquid Freon, connect the Freon can or drum to the unit being flushed, turn the can or drum upside down and open the can or drum valve. Remove the refrigerant lines and flush all components separately. Do not attempt to flush the entire system without first separating the components.

CAUTION: As liquid Freon enters an area of atmospheric pressure its temperature will immediately drop to -21.7°F . Be sure to direct the outlet of the unit or units being flushed into an area where the extreme cold of the escaping Freon will do no harm.

Dry nitrogen may also be used to flush the system components. Drum pressure should not exceed 125 p.s.i.

FAST IDLE ADJUSTMENT

The 1962 Corvair Air Conditioning System requires an engine idle speed of 550 rpm for proper operation. With refrigeration system on and selector in drive (automatic) or gearshift in neutral (manual), adjust the curb idle screw until an engine speed of 550 rpm is attained (fig. 11-58). Also, a head pressure of 300 psi should be indicated for the refrigeration system.

NOTE: If head pressure is lower than 300 psi at idle, the engine will stall when higher pressures are attained under actual operating conditions.

OPERATING INSTRUCTIONS

The Corvair air conditioner, a recirculating type,

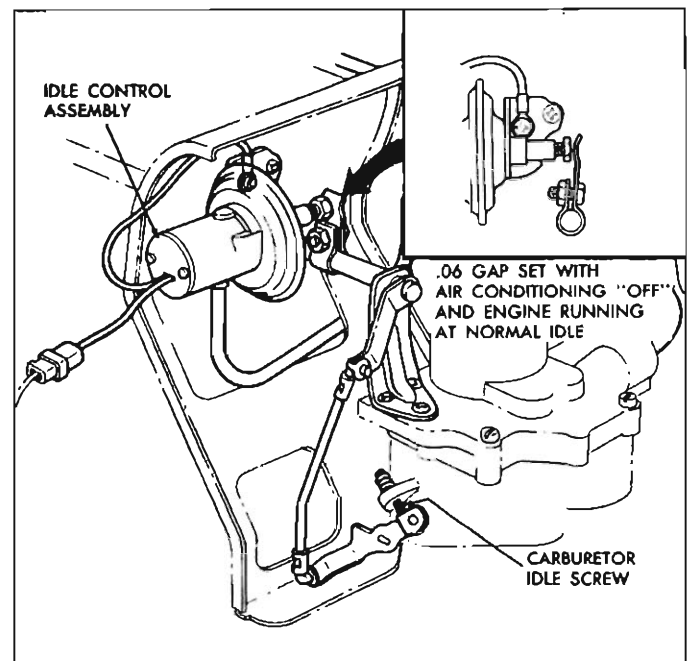

Fig. 11-58—Fast Idle Adjustment

has two knobs to provide control of cool air flow. The air flow can be directed through the two front ball outlets and the center outlet bezel.

Always operate the Air Conditioning System with all windows and vents closed to eliminate drafts, wind and road noise. Cover plates furnished should remain installed over the two engine air recirculating slots during the season when cooling is required. These plates should be removed and stowed on top of the rear sill for the winter, see fig. 11-59.

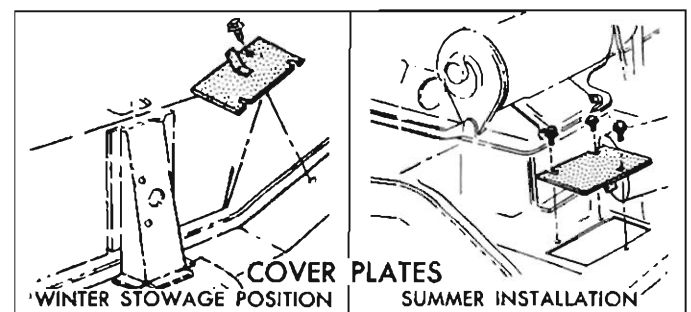

Fig. 11-59—Engine Warming Hole Covers

AIR CONDITIONING CONTROLS

The air conditioning control panel is illustrated in Fig. 11-60.

FAN—Rotate knob to provide the desired blower speed, low, medium or high. The fan will operate no higher than MED speed when headlights are on.

COOL—Pull knob fully out to provide maximum cooling. Intermediate positions provide moderate cooling.



Fig. 11-60—Air Conditioning Controls

CAUTION: Momentary engine overheating may occur if the air conditioner is being operated during extended periods of long uphill pulls or during extreme outside temperatures. Should the "Temp-Press" light come on under such conditions, the car should be stopped and the air conditioner turned off. Check the engine fan belt for excessive looseness and the engine oil for proper level. If these items are satisfactory, start the car, then continue to drive and operate the air conditioner as long as the "Temp-Press" light remains off.

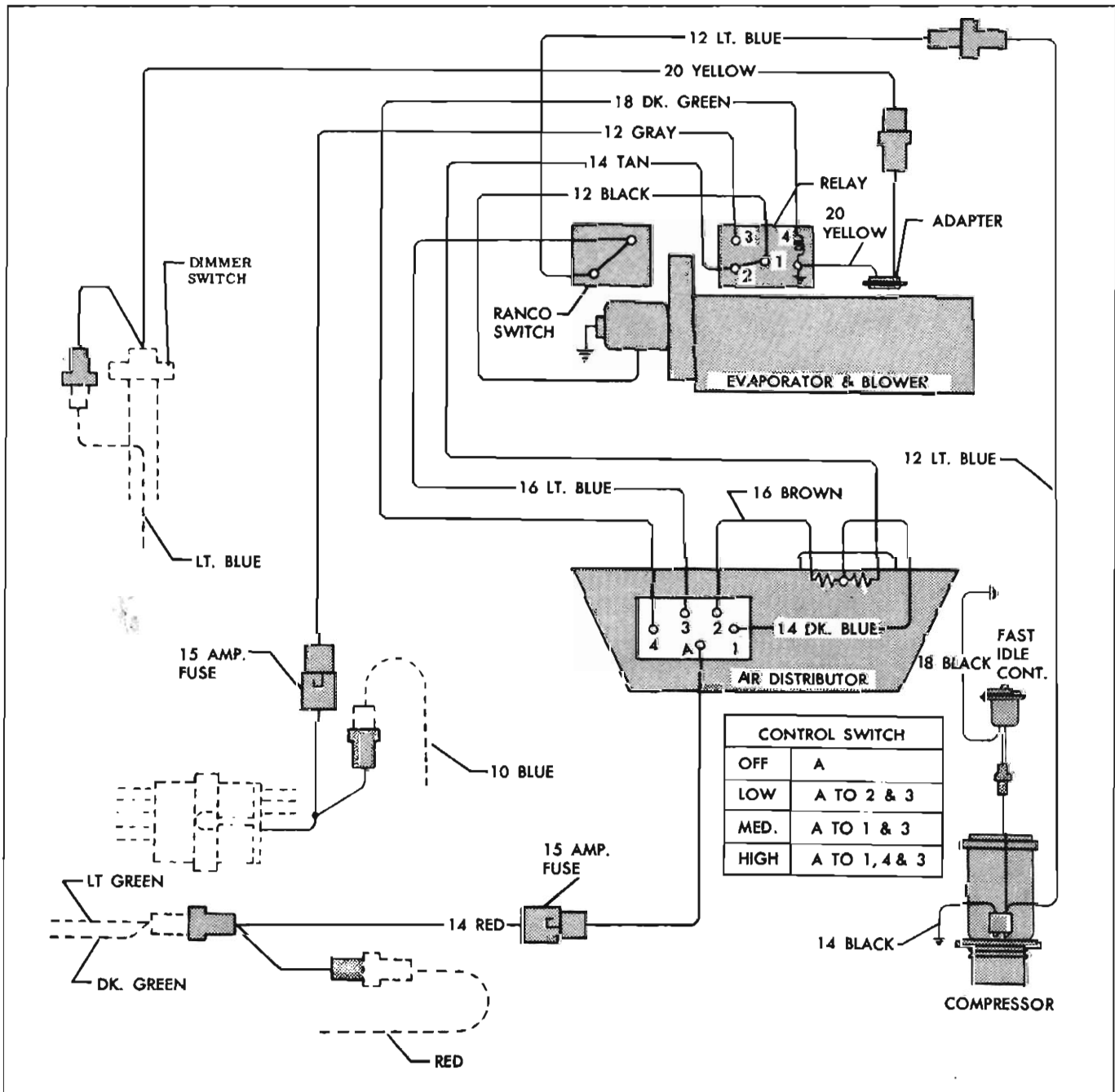

Fig. 11-61—Air Conditioning Wiring Diagram

SPECIAL TOOLS

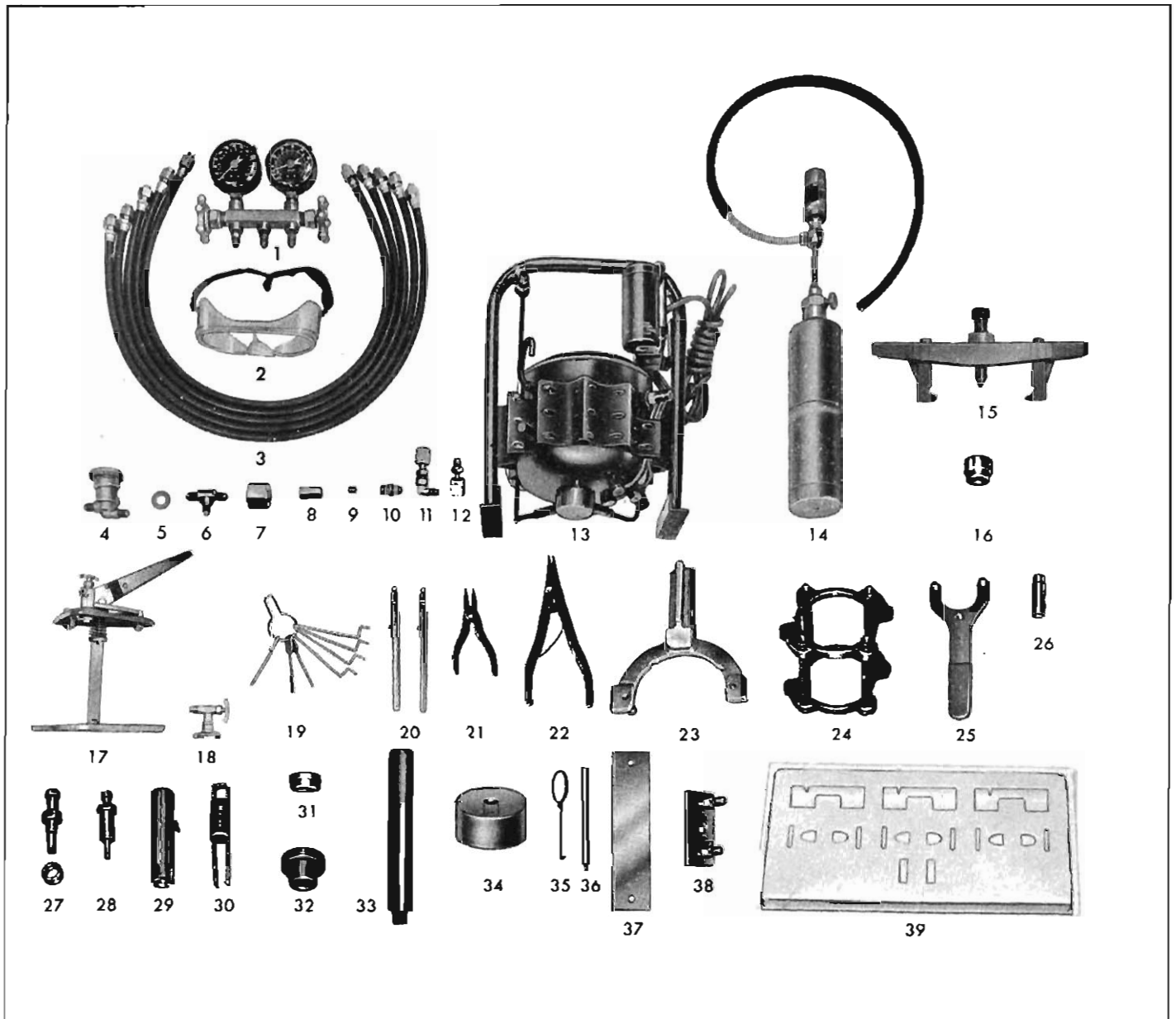

Fig. 11-62—Air Conditioning Special Tools

- | | | | | | |
|--------------|----------------------------|------------|---------------------------------------|------------|--|
| 1. J-5725-A | Gauge Manifold Test Unit | 15. J-8331 | or Puller (With Puller Legs J-9405-1) | 28. J-9480 | Hub and Drive Plate Assembly Installer |
| 2. J-5453 | Goggles | J-9405 | | 29. J-9392 | Seal Remover |
| 3. J-5418 | Gauge Charging Lines (5) | 16. J-9395 | Puller Pilot | 30. J-9393 | Seal Seat Remover |
| 4. J-5462-1 | 2-Way Valve | 17. J-6272 | No. 3 Multi-Opener (3-Can) | 31. J-9398 | Pulley Bearing Remover |
| 5. J-5462-3 | Refrigerant Drum Washer | 18. J-6271 | Fitzall Valve (Single Can) | 32. J-9481 | Pulley and Bearing Installer |
| 6. J-5462-2 | 3-Way "T" | 19. J-7151 | Non-Magnetic Clutch Shims | 33. J-8092 | Handle |
| 7. J-5462-4 | Refrigerant Drum Reducer | 20. J-5421 | Pocket Thermometers (2) | 34. J-9521 | Internal Assembly Support Block |
| 8. J-5462-7 | Female Connection | 21. J-5403 | No. 21 Snap Ring Pliers | 35. J-5139 | Oil Pickup Tube Remover |
| 9. J-5462-8 | Ring Seat | 22. J-6435 | No. 26 Snap Ring Pliers | 36. J-9432 | Needle Bearing Installer |
| 10. J-5462-9 | Pipe Fitting (1/4" x 1/4") | 23. J-9396 | Compressor Holding Fixture | 37. J-9433 | Suction Crossover Seal Installer |
| 11. J-9459 | 90° Gauge Line Adapter | 24. J-9397 | Compressing Fixture | 38. J-9527 | Pressure Test Connector |
| 12. J-5420 | Gauge Line Adapter | 25. J-9403 | Clutch Hub Holding Tool | 39. J-9402 | Parts Tray |
| 13. J-5428 | Vacuum Pump | 26. J-9399 | 9/16" Thin Wall Socket | | |
| 14. J-8094 | Leak Detector | 27. J-9401 | Hub and Drive Plate Assembly Remover | | |