

988375
SEAT BELT INSTRUCTION SHEET
1000 SERIES, CORVAIR, R-10 & TRUCKS



GENERAL MOTORS PARTS DIVISION
GENERAL MOTORS CORPORATION
DETROIT 2, MICHIGAN

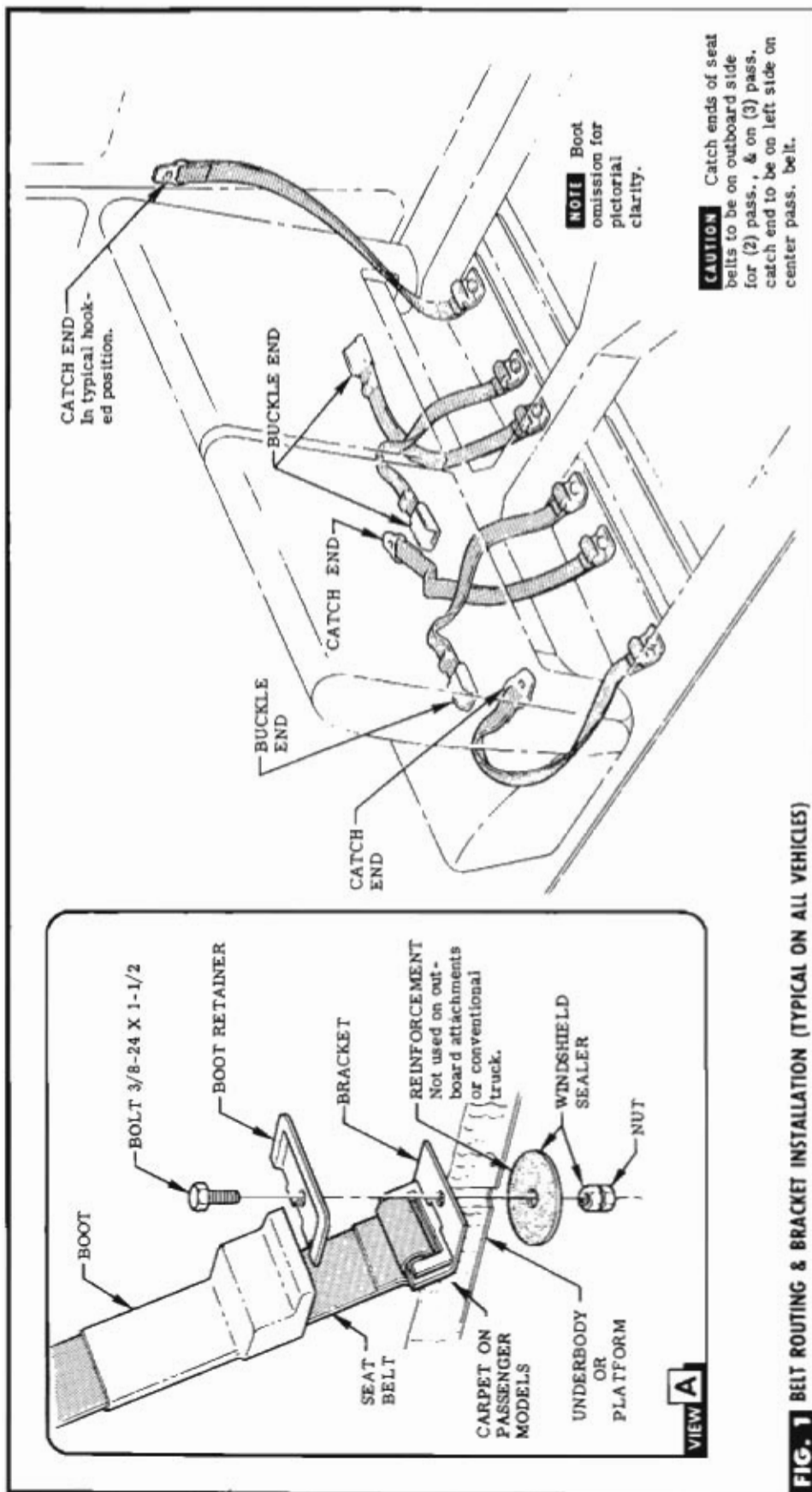

FIG. 1 BELT ROUTING & BRACKET INSTALLATION (TYPICAL ON ALL VEHICLES)

STEP 1 REMOVE SEAT CUSHIONS & BACKS OR FOLD SEATS FORWARD FOR ACCESSIBILITY, ALSO TURN BACK FLOOR MAT AT AREA OF INSTALLATION. PIERCE & SLIT AREA OF MAT AT BRACKET LOCATIONS.

STEP 2 LOCATE, CENTERPUNCH & DRILL HOLES THRU UNDERBODY OR PLATFORMS. SEE VIEW A &

FIG. 2 - 1000 SERIES

FIG. 3 - CORVAIR

FIG. 4 - LIGHT DUTY (EXCEPT TILT CABS)

FIG. 5 - TILT CABS

FIG. 6 - PANEL TRUCKS

STEP 3 INSTALL A BRACKET, REINFORCEMENT & (2) NUTS AT EACH DRILLED HOLE. COAT REINFORCEMENT & NUTS WITH WINDSHIELD SEALER PRIOR TO INSTALLATION. SEE VIEW A. **NOTE** Where Bracket will be exposed, also

attach Book Retainer when installing Bracket.

STEP 4 ON 4-DOOR 1000 SERIES & 2 & 4 DOOR CORVAIRS, FRONT SEAT BACK MUST BE SLIT, PRIOR TO ATTACHING SEAT BELTS TO BRACKETS. SEE FIG. 10

STEP 5 ATTACH SEAT BELTS TO BRACKET & ADJUST TO PROPER LENGTH. SEE VIEW A & FIG. 13. **NOTE** If Boots are to be installed, thread Belt thru Boot prior to attaching. Also if seat has been slit, thread thru seat prior to installing Boot, or attaching to Bracket.

STEP 6 REPLACE SEATS.

STEP 7 INSTALL COAT HOOKS & SCREWS FURNISHED FOR OUTBOARD BELT STOWAGE. SEE FIG. 11.

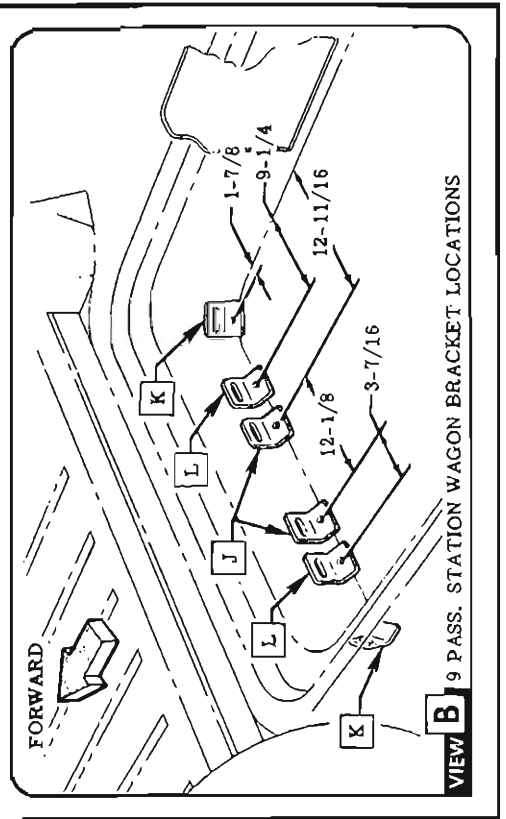
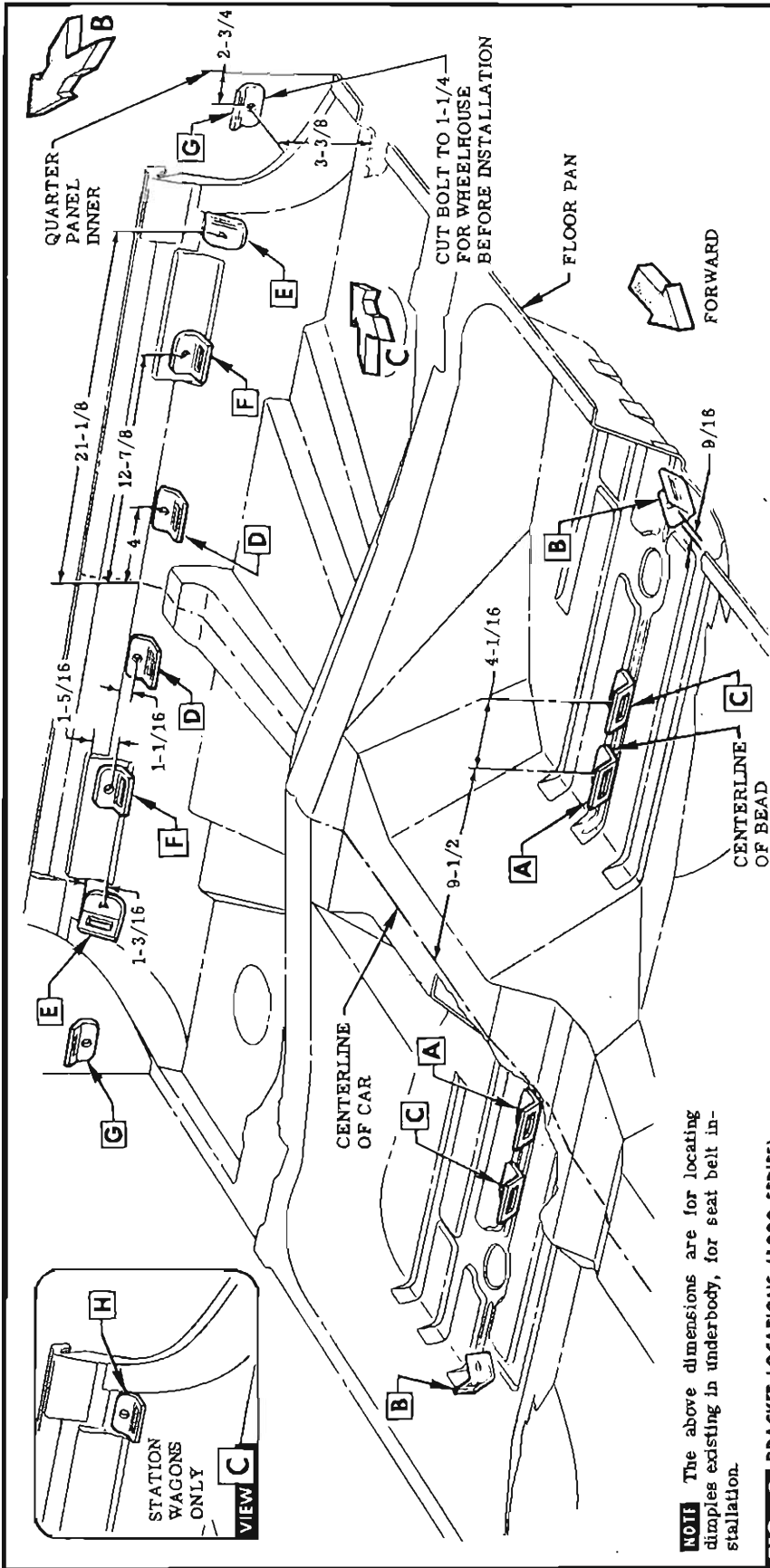

NOTE The above dimensions are for locating dimples existing in underbody, for seat belt installation.

FIG. 2 BRACKET LOCATIONS (1000 SERIES)

MODEL	FRONT SEAT 2 PASS. 3 PASS.	REAR SEAT 2 PASS. 3 PASS.	INT. SEAT 2 PASS. 3 PASS.
4 DOOR SEDAN	[A] [B] [C]	[D] [G] [F]	
4 DOOR SPORT SEDAN	[A] [B] [C]	[D] [G] [F]	
2 DOOR SEDAN	[A] [B] [C]	[D] [G] [F]	
CONVERTIBLE	[A] [B] [C]	[D] [E]	
SPORT COUPE	[A] [B] [C]	[D] [E]	
UTILITY SEDAN	[A] [B] [C]		
6 PASS. STA. WAGON	[A] [B] [C]	[D] [H] [E]	
9 PASS. STA. WAGON	[A] [B] [C]	[J] [K] [L]	[D] [H] [F]
SEDAN DELIVERY	[A] [B] [C]	* [C]	* IF R. P. O. SEAT EXISTS
PICK-UP DELIVERY	[A] [B] [C]		

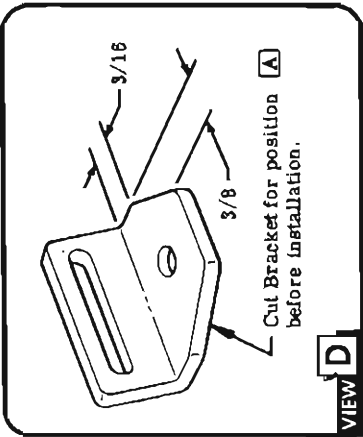

VIEW D

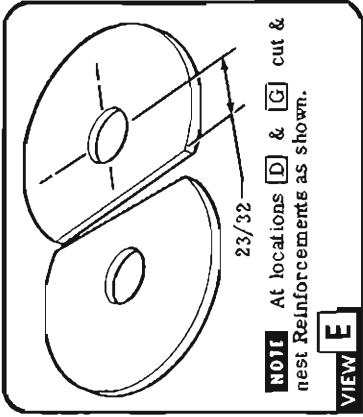

VIEW E

TO LOCATE BRACKET SCRIBE HORIZONTAL LINE (R. H. & L. H. SIDE)

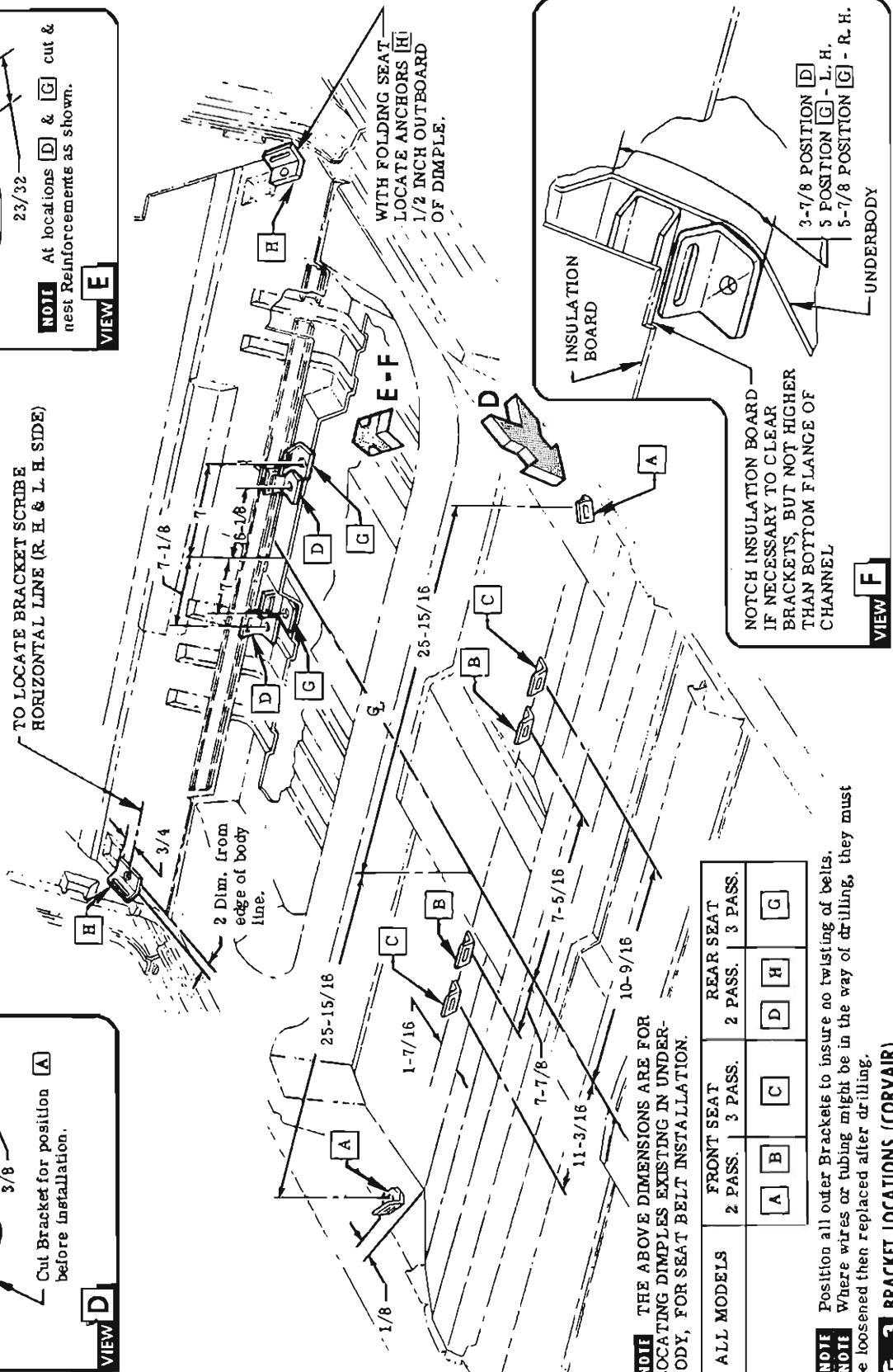

VIEW F

NOTE THE ABOVE DIMENSIONS ARE FOR LOCATING DIMPLES EXISTING IN UNDERBODY, FOR SEAT BELT INSTALLATION.

ALL MODELS	FRONT SEAT		REAR SEAT	
	2 PASS.	3 PASS.	2 PASS.	3 PASS.
	A	B	C	C
			D	H
				G

NOTE Position all outer Brackets to insure no twisting of belts.
NOTE Where wires or tubing might be in the way of drilling, they must be loosened then replaced after drilling.

FIG. 3 BRACKET LOCATIONS (CORVAIR)

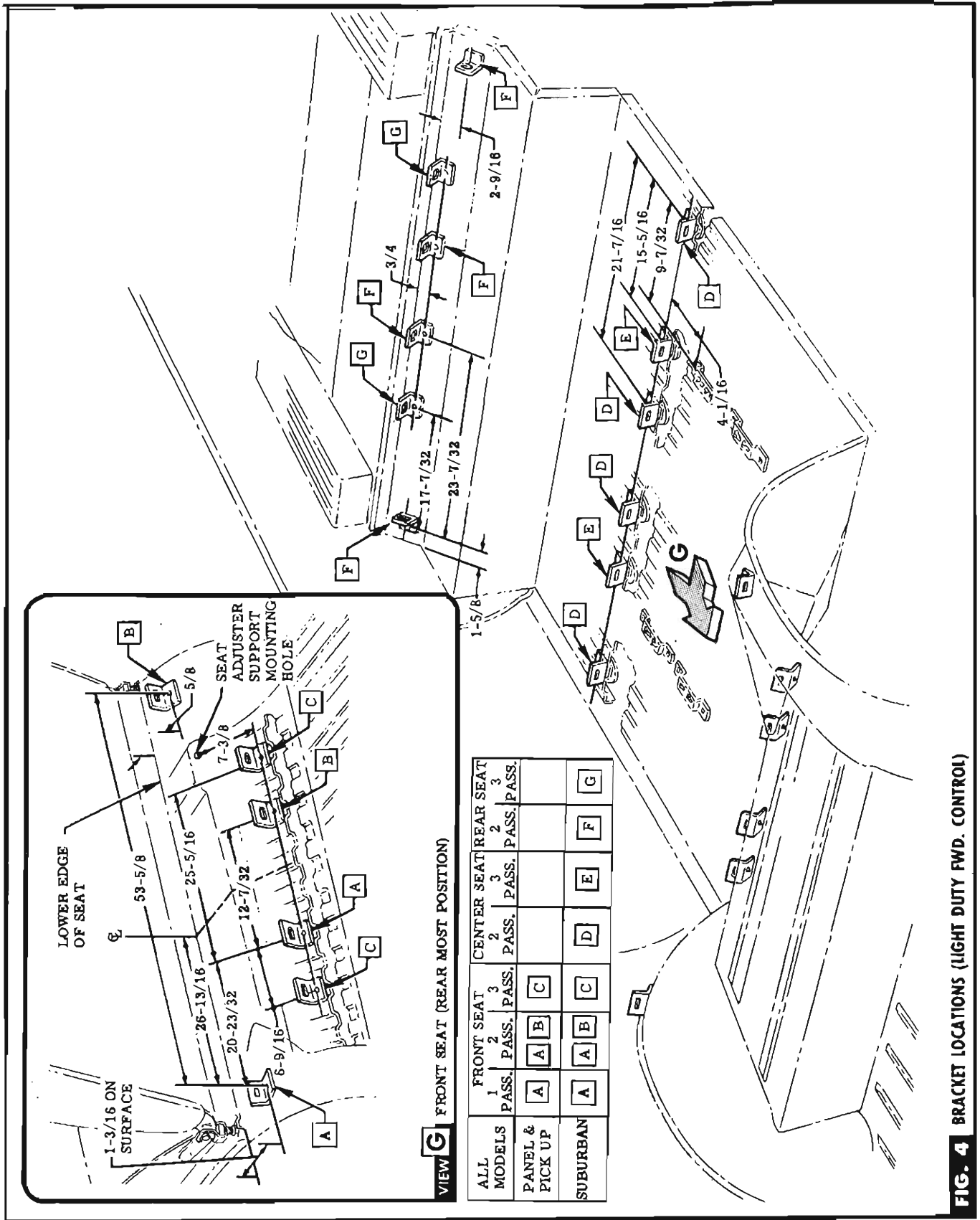

FIG. 4 BRACKET LOCATIONS (LIGHT DUTY FWD. CONTROL)