

985273

INSTRUMENT PANEL COMPARTMENT LIGHT SWITCH INSTRUCTION SHEET

CHEVROLET - CORVAIR - CORVAIR 95 - TRUCK & CHEVY

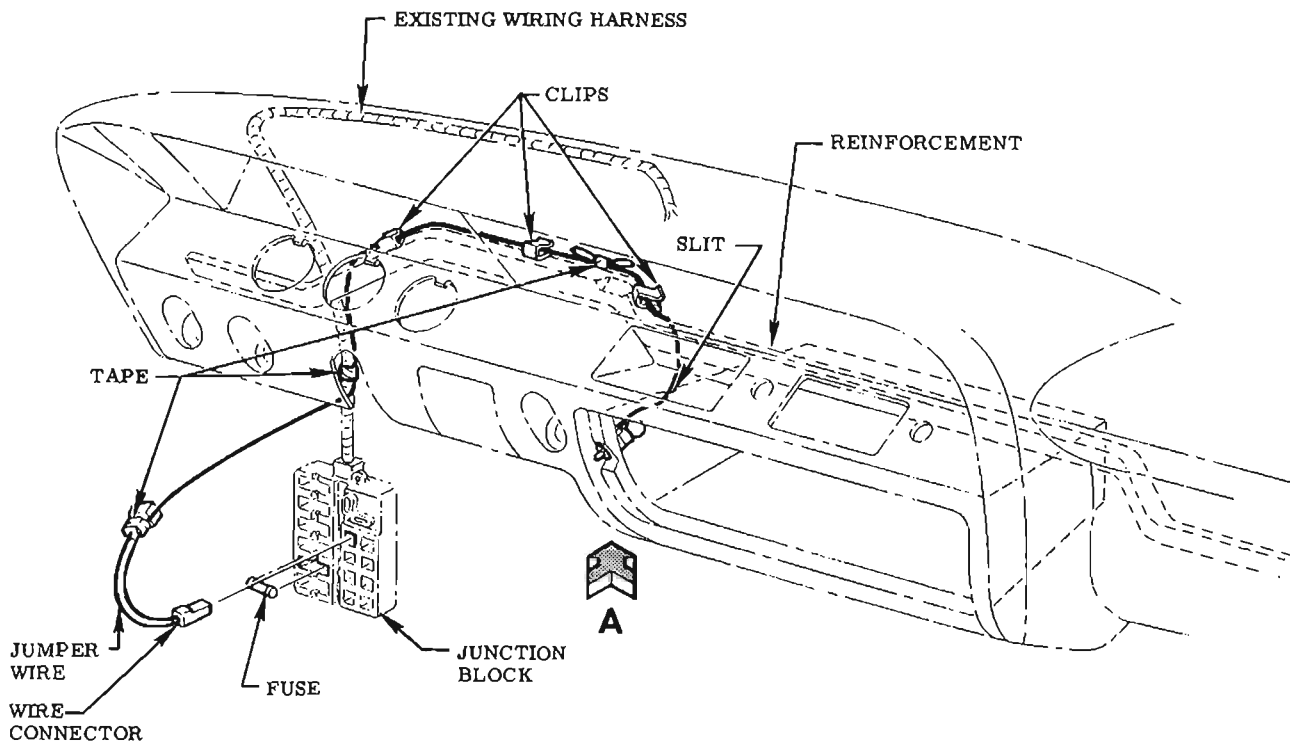
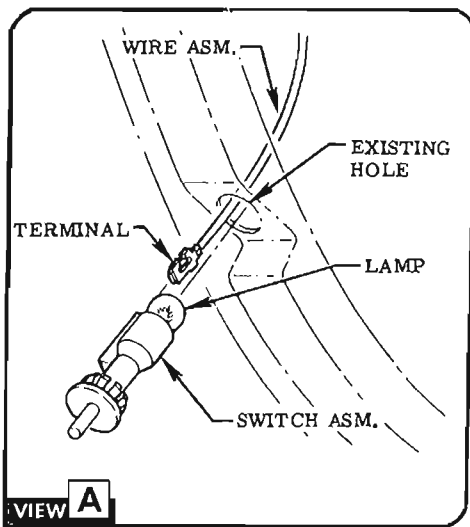

FIG. 1 CHEVROLET

STEP 1 ROUTE WIRE TERMINAL THRU SLIT IN UPPER LEFT HAND CORNER OF INSTRUMENT PANEL COMPARTMENT & THRU HOLE IN UPPER LEFT SIDE OF COMPARTMENT OPENING. SEE FIG. 1 & VIEW A.

STEP 2 ASSEMBLE WIRE TERMINAL TO SWITCH. INSERT LAMP & PRESS SWITCH INTO POSITION. SEE VIEW A.

STEP 3 ROUTE WIRE ALONG REINFORCEMENT & ATTACH WITH THREE OF PROVIDED CLIPS. ROUTE WIRE WITH EXISTING HARNESS TO JUNCTION BLOCK. TAPE WIRE TO

HARNESS CLOSE TO JUNCTION BLOCK. SEE FIG. 1.

STEP 4 PLUG WIRE CONNECTOR INTO EITHER RECEPTACLE MARKED "CTSY." SEE FIG. 1. **NOTE** If receptacle is occupied, remove existing wire & connect to jumper wire.

STEP 5 INSERT FUSE INTO RECEPTACLE MARKED "TAIL-LPS." SEE FIG. 1.

STEP 6 LOOP EXCESS WIRE & TAPE. SEE FIG. 1.
NOTE Discard remaining parts.

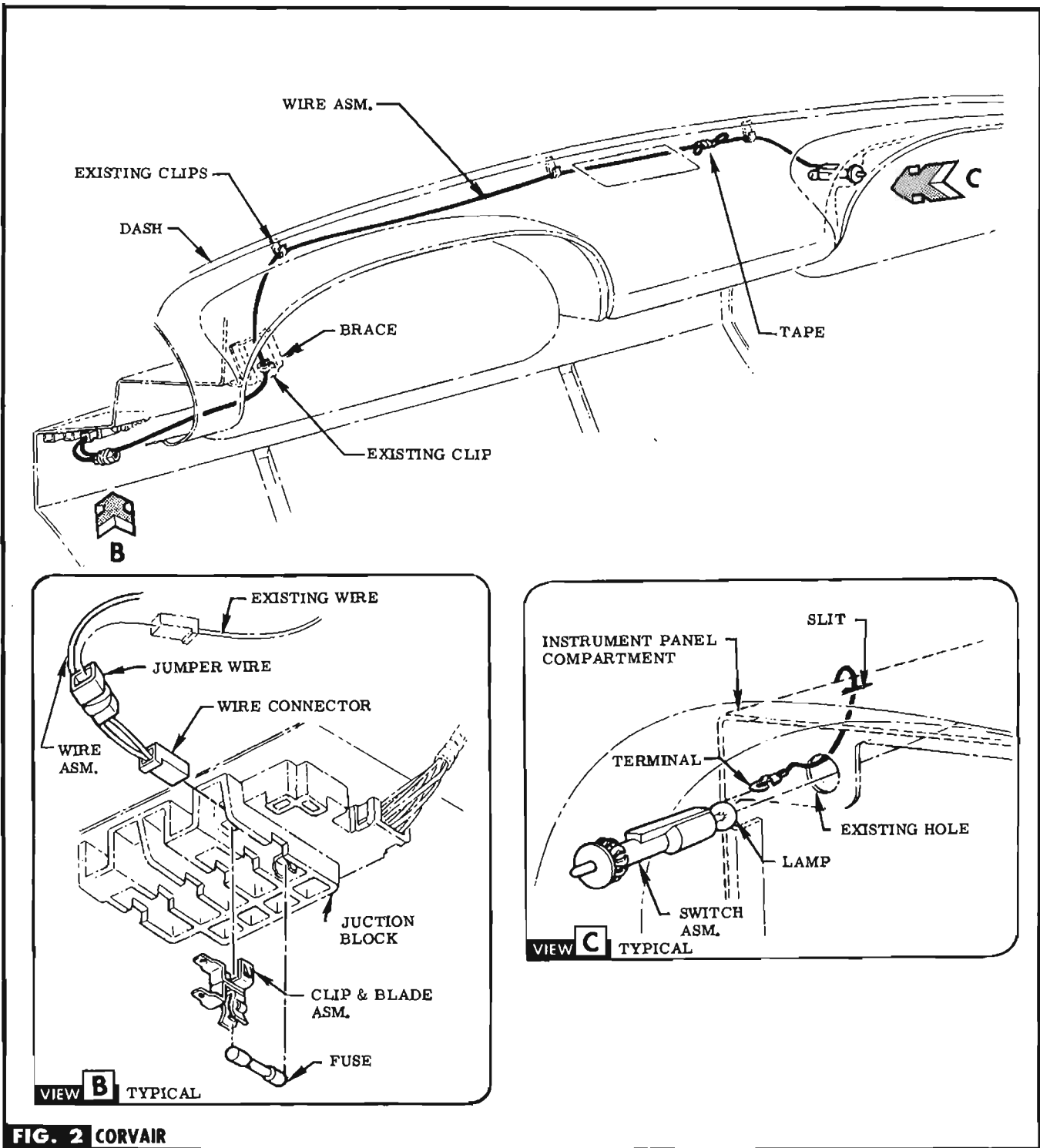

FIG. 2 CORVAIRE

STEP 1a ROUTE WIRE TERMINAL THRU SLIT IN UPPER LEFT HAND CORNER OF INSTRUMENT PANEL COMPARTMENT & THRU HOLE IN UPPER LEFT SIDE OF COMPARTMENT OPENING. SEE FIG. 2 & VIEW C.

STEP 2a ASSEMBLE WIRE TERMINAL TO SWITCH. INSERT LAMP & PRESS SWITCH INTO POSITION. SEE VIEW C.

STEP 3a ROUTE WIRE THRU EXISTING CLIPS (ON DASH) TO

JUNCTION BLOCK. SEE FIG. 2.

STEP 4a PRESS CLIP & BLADE INTO RECEPTACLE MARKED "GL. BOX LP.", INSERT FUSE & CONNECT WIRE. SEE VIEW D. **NOTE** If receptacle is occupied, remove existing wire & connect to jumper wire. Discard clip & blade asm. & fuse.

STEP 5a LOOP & TAPE EXCESS WIRE. SEE FIG. 2.

NOTE Discard remaining parts.

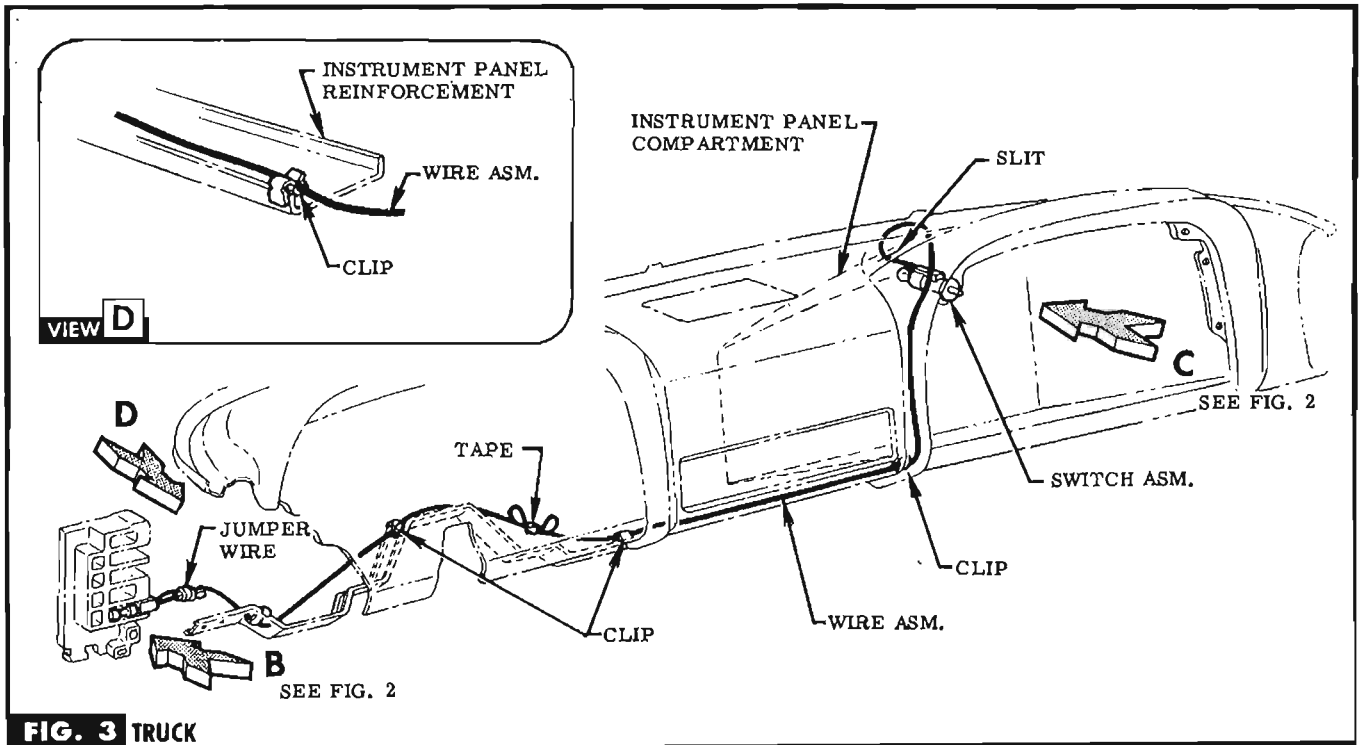

FIG. 3 TRUCK

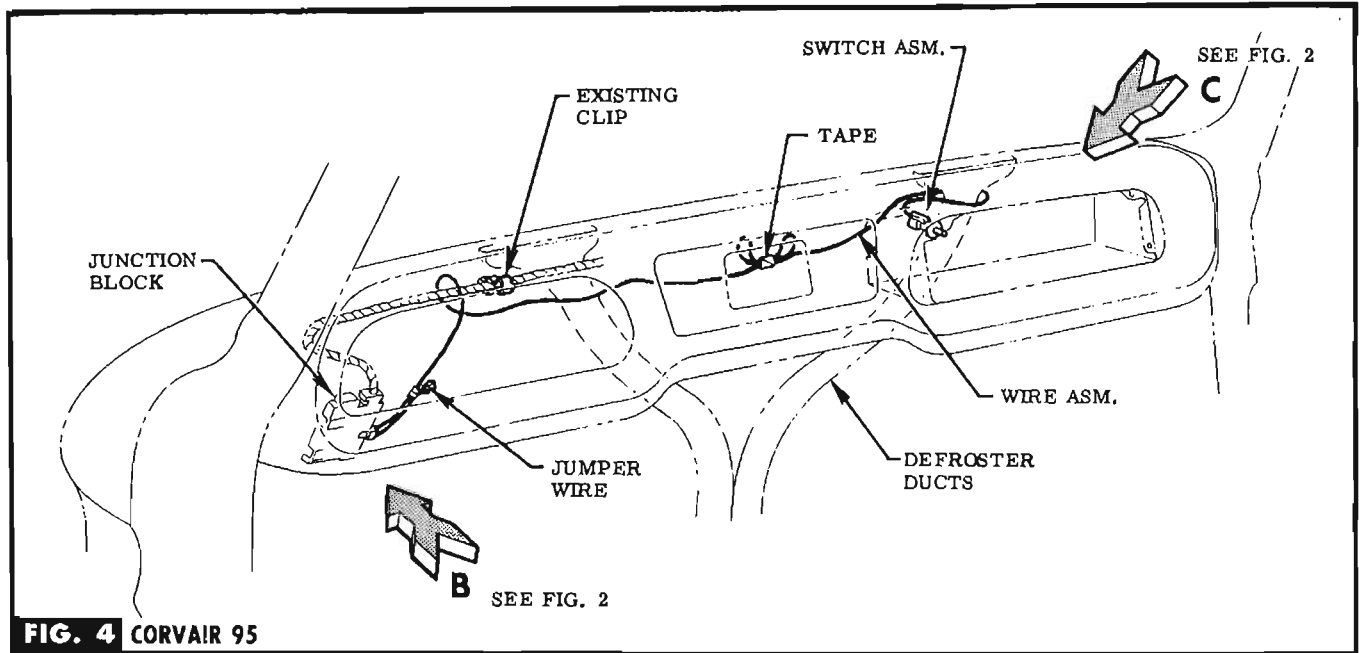

FIG. 4 CORVAIR 95

STEP 1b ROUTE WIRE TERMINAL THRU SLIT IN UPPER LEFT HAND CORNER OF INSTRUMENT PANEL COMPARTMENT & THRU HOLE IN UPPER LEFT SIDE OF COMPARTMENT OPENING. SEE FIG. 3 OR 4 & VIEW C, FIG. 2.

STEP 2b ASSEMBLE WIRE TERMINAL TO SWITCH. INSERT LAMP & PRESS SWITCH INTO POSITION. SEE FIG. 3 OR 4 & VIEW C, FIG. 2.

STEP 3b (CORVAIR 95) ROUTE WIRE TO JUNCTION BLOCK BY LOOPING AROUND R. H. DEFROSTER DUCT, PASS OVER L. H. DEFROSTER DUCT, LOOP AROUND EXISTING WIRING HARNESS ALONGSIDE OF EXISTING CLIP. SEE FIG. 4.

STEP 4b (TRUCK) MOUNT CLIPS ON FORWARD FLANGE OF INSTRUMENT PANEL REINFORCEMENT & ROUTE WIRE THRU THESE CLIPS TO JUNCTION BLOCK. SEE FIG. 3, & VIEW D.

STEP 5b PRESS CLIP & BLADE INTO RECEPTACLE MARKED "GL. BOX LP." INSERT FUSE & CONNECT WIRE. SEE VIEW D & FIG. 2. **NOTE** If receptacle is occupied, remove existing wire & connect to jumper wire.

STEP 6b LOOP & TAPE EXCESS WIRE. SEE FIG. 3 OR 4. **NOTE** Discard remaining parts.