

985305

LEVEL PLATFORM INSTRUCTION SHEET

1244-54 MODELS

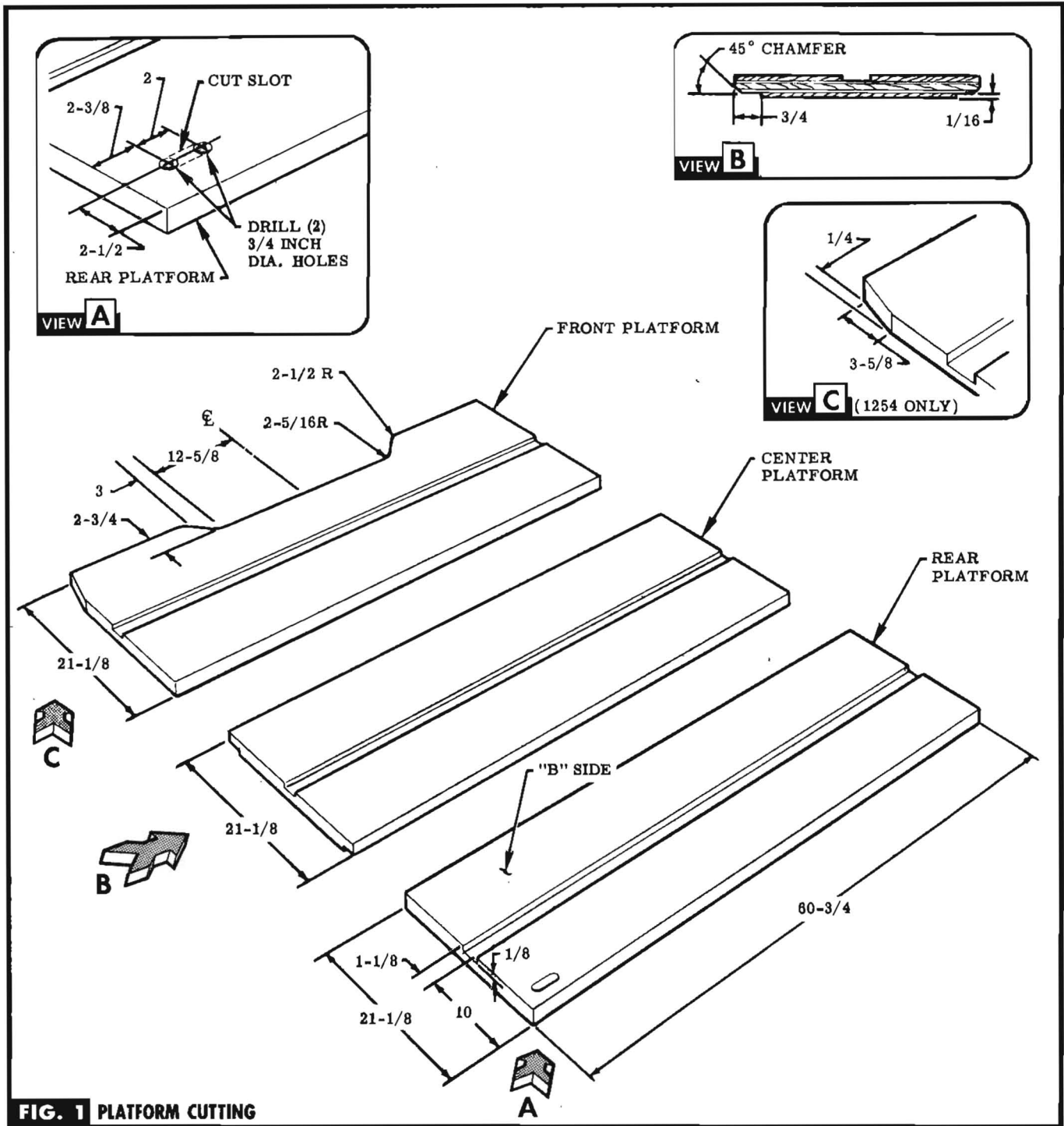

FIG. 1 PLATFORM CUTTING

**STEP 1** PURCHASE LOCALLY ENOUGH 3/4 INCH (5-PLY EXTERIOR GRADE "AB") PLYWOOD TO MAKE (3) EQUAL PARTS.

**STEP 2** CUT (3) EQUAL PARTS OF PLYWOOD TO DIMENSION SHOWN. SEE FIG. 1.

**STEP 3** CUT GROOVE IN ALL (3) PARTS ON "B" SIDE SEE FIG. 1.

**STEP 4** DRILL (2) HOLES & CUT SLOT IN (1) PART DESIGNATED "REAR PLATFORM". SEE VIEW A.

**STEP 5** CUT GROOVES & CHAMFER ALONG EDGES ON OPPOSITE SIDE OF GROOVE ON (1) PART DESIGNATED "CENTER PLATFORM". SEE VIEW B.

**STEP 6** CUT OUT AREA ON REMAINING PART DESIGNATED "FRONT PLATFORM". SEE FIG. 1, & VIEW C.

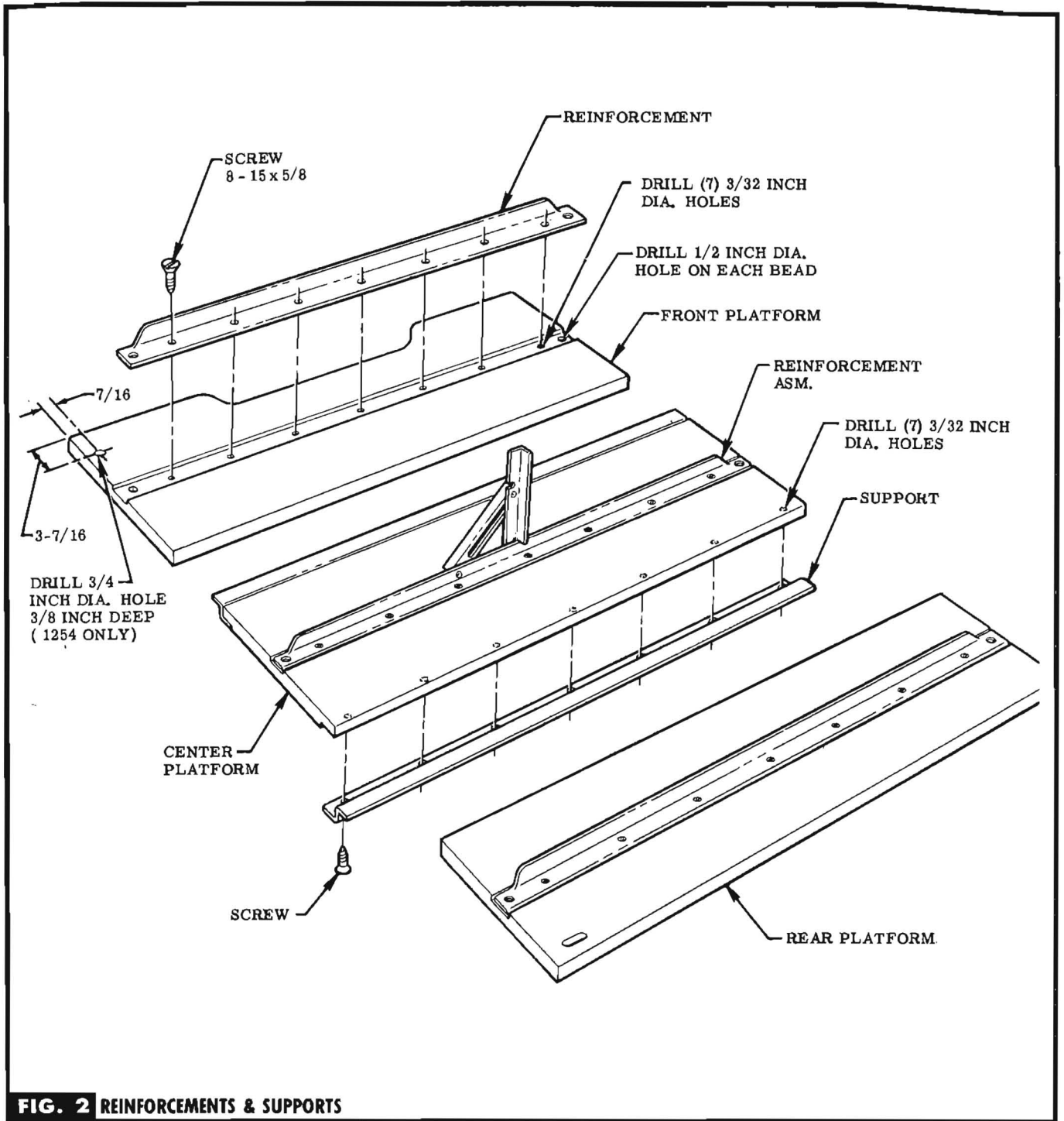

**FIG. 2 REINFORCEMENTS & SUPPORTS**

**STEP 7** USING REINFORCEMENTS PROVIDED AS A TEMPLATE, LOCATE & DRILL HOLES IN UNDERSIDE OF PLATFORMS. **NOTE** Do not drill thru plywood with 3/32 inch drill. SEE FIG. 2.

**STEP 8** USING SUPPORTS PROVIDED AS A TEMPLATE, LOCATE & DRILL HOLES IN TOP OF CENTER PLATFORM.

SEE FIG. 2. **NOTE** Drill thru permissible.

**STEP 9** ATTACH REINFORCEMENTS & SUPPORTS TO PLATFORMS WITH SCREWS PROVIDED. SEE FIG. 2.

**STEP 10** (ON 1254 MODELS ONLY) LOCATE & DRILL HOLE IN R. H. CORNER OF FRONT PLATFORM. SEE FIG. 2.

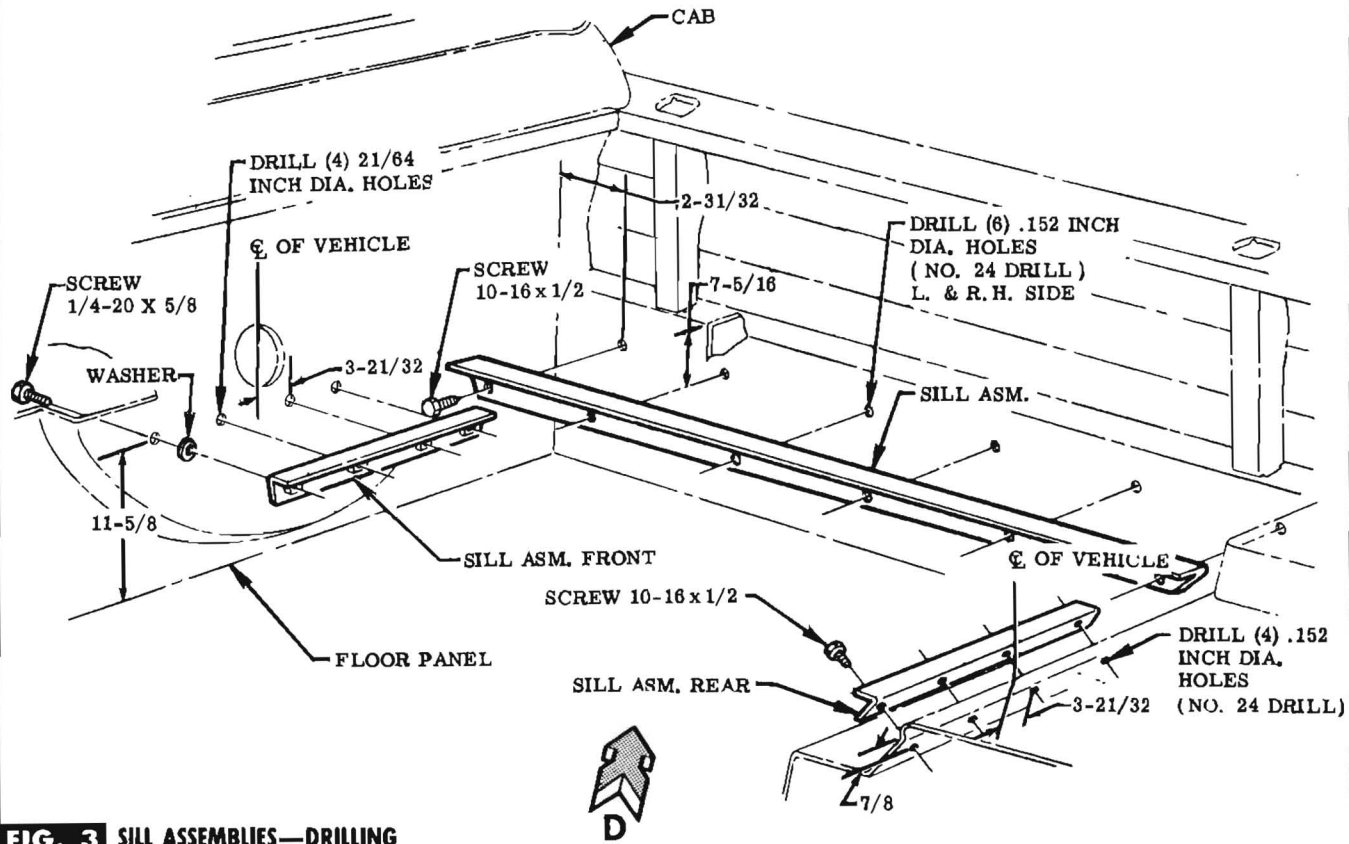
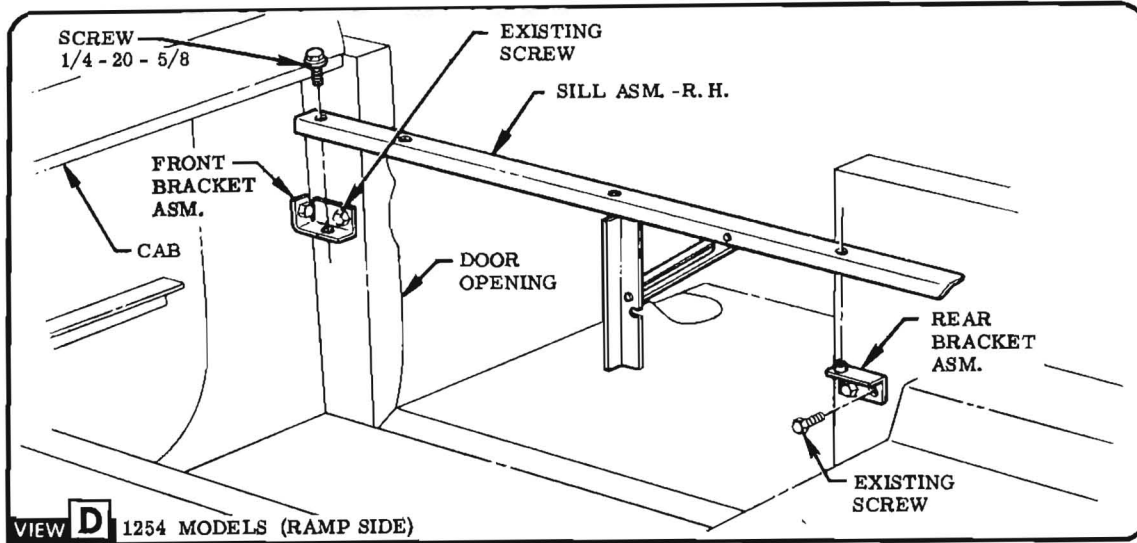

**FIG. 3 SILL ASSEMBLIES—DRILLING**

**STEP 11** REMOVE & RETAIN SPARE TIRE & ATTACHING PARTS.

**STEP 12** ON ALL MODELS, LOCATE CENTER PUNCH & DRILL TWO INSIDE HOLES FOR FRONT & REAR SILL ASSEMBLIES & USING THEM AS A TEMPLATE, LOCATE, CENTER PUNCH & DRILL REMAINING HOLES. SEE FIG. 3

**STEP 13** LOCATE, CENTER PUNCH & DRILL FORWARD HOLES IN SIDE SILL ASSEMBLIES & USING THEM AS A

TEMPLATE LOCATE, CENTER PUNCH & DRILL REMAINING HOLES. SEE FIG. 3.

**STEP 14** INSTALL ALL SILL ASSEMBLIES WITH ATTACHING PARTS PROVIDED. SEE FIG. 3.

**STEP 15** ON 1254 MODELS ONLY, REMOVE EXISTING SCREWS ON R.H. SIDE PANEL & INSTALL BRACKETS PROVIDED WITH EXISTING SCREWS. SEE FIG. 3 & VIEW D.

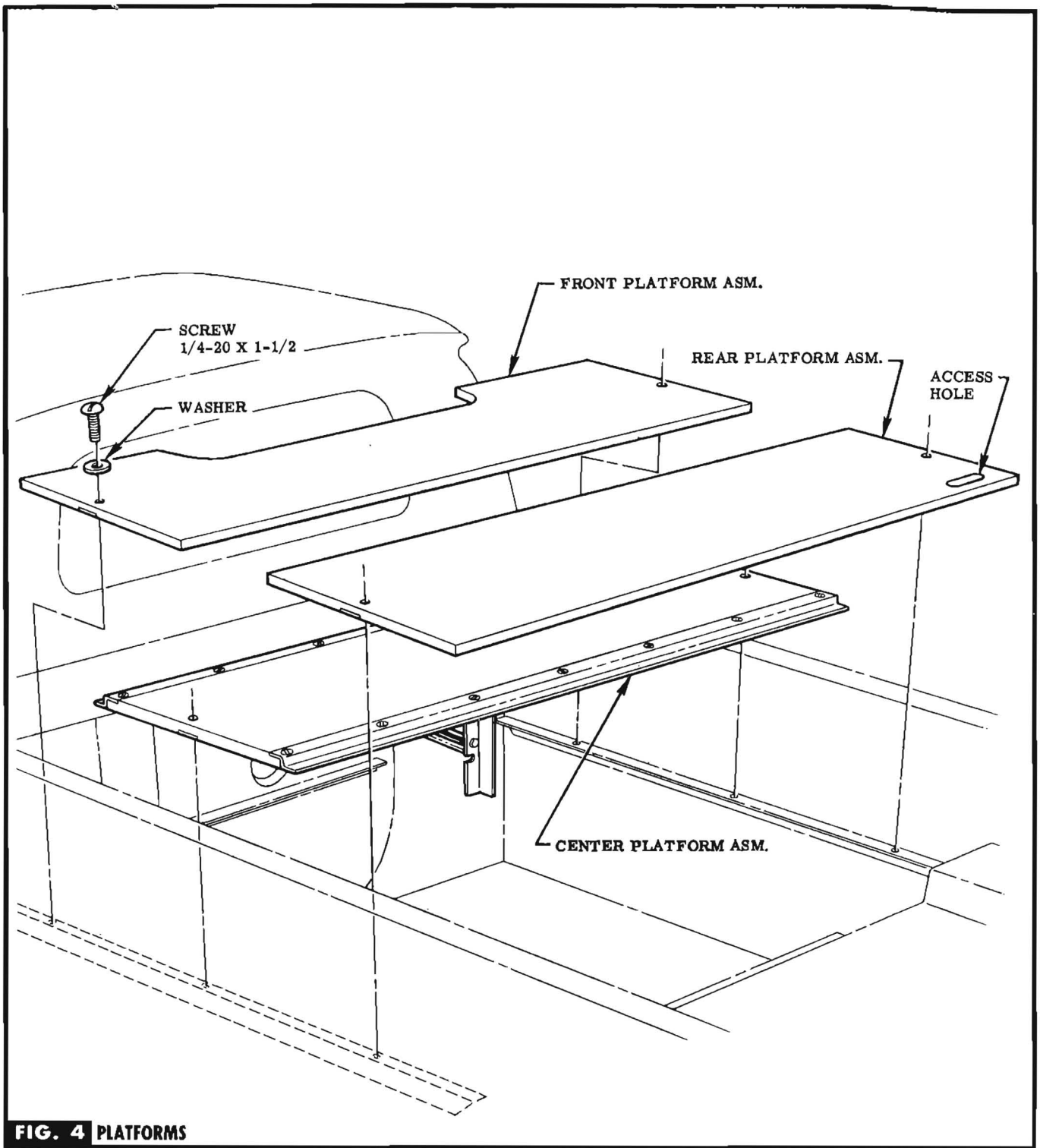

**FIG. 4 PLATFORMS**

**STEP 16** REINSTALL SPARE TIRE.

**STEP 17** INSTALL PLATFORMS & SECURE WITH ATTACHING PARTS PROVIDED. SEE FIG. 4.

**STEP 18** TO REMOVE PLATFORMS, REMOVE SCREWS & START BY LIFTING REAR PLATFORM, USING ACCESS HOLE ON R. H. SIDE. SEE FIG. 4.