

THE VAIR STREET JOURNAL

WESTERN PENNS

JUNE 1982

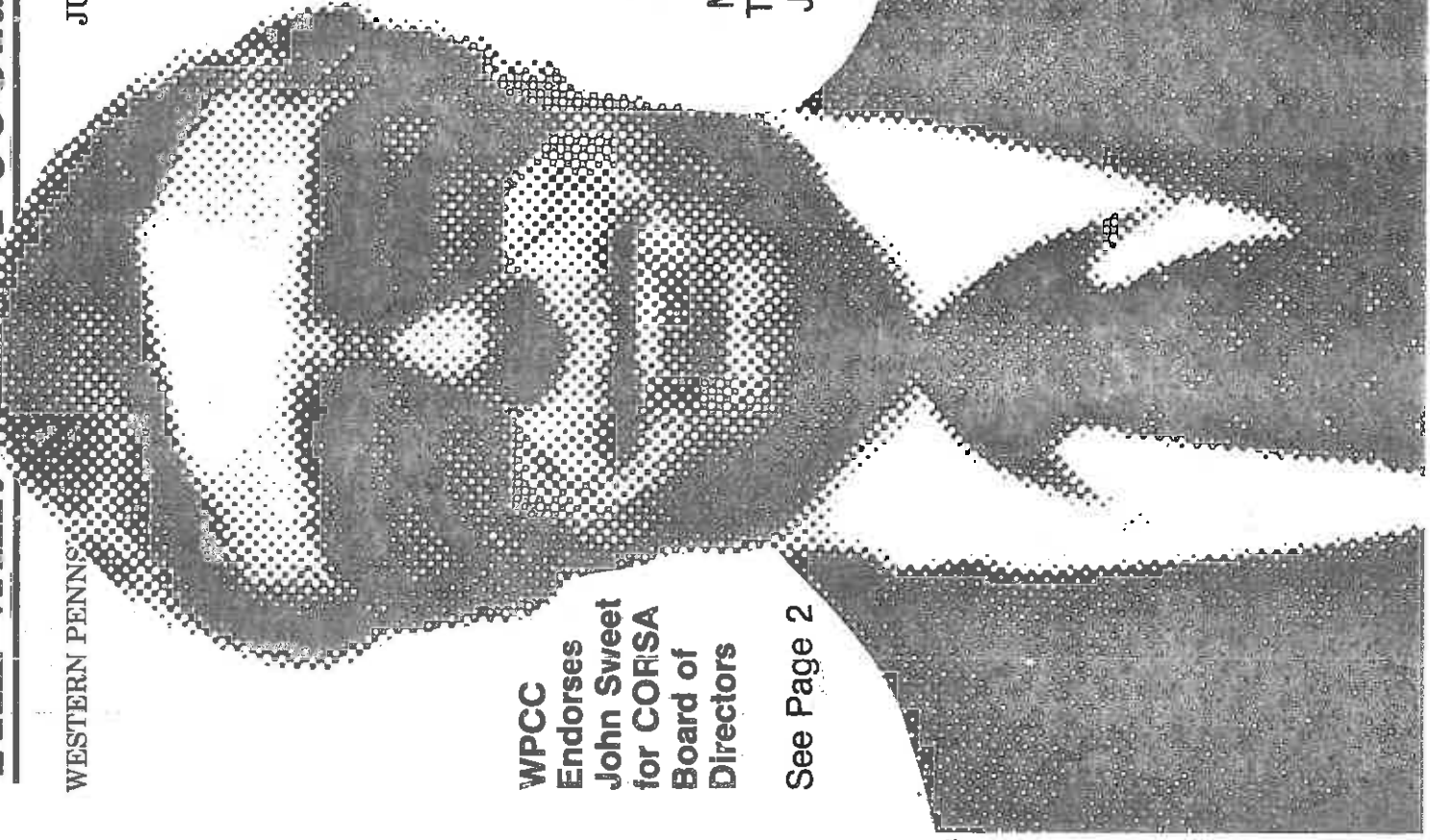

**WPCC
Endorses
John Sweet
for CORISA
Board of
Directors**

See Page 2

**Next
Meeting
Tuesday
June 22**

THE WESTERN PENNSYLVANIA CORVAIR CLUB WANTS YOU!!

MEMBERSHIP APPLICATION

That sure is a great little car you're driving. In fact the Corvaire is probably the most courageous, creative, and potentially the best engineered automobile to come out of Detroit in modern times. As you may already know, a two year study conducted by the U.S. Dept. of Transportation, and suggested by Mr. Ralph Nader, concluded: "The Corvaire quantitatively meets or exceeds standards set by contemporary automobiles in stability, cornering, and roll-over tests." It is also the only car ever proven safe in a court of law!!!

Next time a fellow Corvaire driver waves to you, hold your head high and wave back, since you have something in common. "The Vair" however, is far from a common car. They are now quite rare, gaining in value, and have so many sensible features when compared to today's plastic and cardboard cars. Isn't it great not spending money on antifreeze and snow tires for example!

We are a chartered chapter of "The Corvaire Society of America" (CORSA), a rapidly growing international organization now boasting over 8,000 members. Like all automobile marque clubs of international stature, CORSA requires all chapter members to also belong to CORSA, the international Corvaire club.

The long range goals of both clubs is simply to increase the enjoyment and preservation of the Corvaire automobile. We provide - technical and historic information, parts procurement, professional publications, and an international classified ad service. We sponsor and participate in - Corvaire shows, rallies, time trials, autocross events, mini conventions, and national conventions. We love driving to local points of interest, touring style, in Corvaire convoys. We have parties, picnics, and dinners, there's always plenty of Corvaire talk, and all of our events are family affairs. Our membership includes people from every imaginable age group, background, and profession. Our chapter provides a twelve page monthly newsletter, and CORSA provides a beautiful monthly magazine named "The CORSA Communicates".

We would love to welcome you, your family, and your Corvaire into our club. Simply complete the attached application and mail it to Al Friend, WPCC Liaison. Remember, the nicest people drive Corvaire, and "You're Always Ahead With Your Engine Behind." Hope to see you soon.

MEETINGS: The 4th Tuesday of every month, 8 p.m. at the Good Shephard Lutheran Church, Monroeville, Pennsylvania

DUES: LOCAL \$9 per calendar year, of 75¢ for each remaining month of the current year. Half price for immediate family. Payable to: WPCC.

CORSA Our charter requires that all WPCC members, also belong to CORSA, our national organization. New members must enclose a completed CORSA application and a check payable to CORSA, Inc. for \$14. If you already belong to CORSA, then send only WPCC information.

MAIL TO: W.P.C.C./o Al Friend, 3677 Forbes Trail Dr. Murrysville, PA 15668 (412)325-2588

NAME _____ AGE _____ OCCUPATION _____ PHONE _____
ADDRESS _____ ZIP _____ DATE _____
CORSA MEMBER? YES NO CORVAIRES OWNED, YR: MODEL _____
RECOMMENDED BY _____ AMOUNT PAID _____ OTHER CAR CLUBS _____
OTHER INFORMATION: _____

Minutes of the Last Meeting

The monthly WPCC evening began with a dinner at Carbones Restaurant with 32 persons in attendance. Following dinner the group traveled to the residence of Jean & Bill Brill where a regular monthly meeting was conducted.

The meeting was called to order at 9:15 p.m. by Pres. Isadore Krouse and 16 men signed the roster. The minutes of the previous meeting were read and approved. J.Lane approved/J.Sweet, 2nd.

OLD BUSINESS -

1. J.Sweet reviewed the work to be done on the engine to be raffled. Deadline to complete the component parts is the 2nd week of July. W.Matenkowsky volunteered to rebuild the 4 carburetors. Other parts of the dismantled '62 coupe will be sold to members at special low prices. Discussion of sale of raffle tickets at the Natl. Convention followed.

2. J.Sweet candidacy for a National office was promised support by the local club.

3. Pres. Krouse announced the new WPCC caps arrived and may be purchased at \$5. each. Additional caps will be available by placing an order with Isadore.

4. J.Lane asked as many members as possible to attend the Gateway Clipper Parade on Sat. 5/29/82. Parade will begin at 10 a.m. and our Position is #23. Meet at 22nd & Carson Sts. in South Side.

5. B.Brill mentioned that he heard the Xmas Party date was not satisfactory to all. All members present agreed the Dec. 19th was a good one.
NEW BUSINESS -

1. J.Sweet announced that a new trailer hitch was purchased for the club for \$20. The action was approved by the members. He also mentioned that Corvaire parts are disappearing rapidly from the market and suggested buying any parts that become available, providing they are at a fair price.

2. T.Phelps discussed the next event at Nelson Ledges, near Warren Ohio on Sun., 6/13/82. He suggested a picnic lunch for those planning to attend.

B.Brill made a motion to adjourn the meeting, 2nd A.Miller. Meeting adjourned by I.Krouse at 10:35 pm.

From the Editor's Desk

Last month's issue of the Journal was to have had John Sweet as "Another Corvair Lover", but because of our earlier than normal publication deadline, it didn't appear in that issue. I felt especially bad because John went through the trouble of writing his bio while on a flight to Los Angeles. The fault was mine for waiting too long to have him write it.

Things worked out for the best though. John is featured along with the other candidates for CORSA board of directors in the June issue of the COMMUNIQUE. So why not feature him in this month's Vair Street Journal?

The point then of this issue is to make everyone aware that John is on the ballot for CORSA national board of directors. John wants the job, and we know he will do a creditable job. WPCC endorses him, and now it remains for us, the membership, to support him through our votes.

It's interesting to note that there were so few votes cast in the Eastern Division last year. If every member of WPCC had voted for John, he would have won. So please vote. Take the time and a twenty cent stamp and follow the instructions for voting detailed on the dust jacket of your COMMUNIQUE. Do it TODAY. ed.

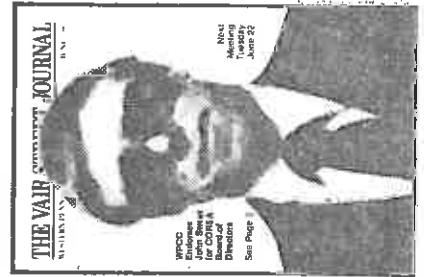
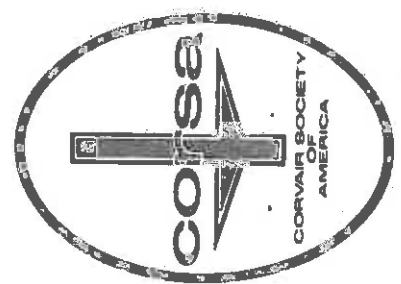

Another Corvair Lover — John Sweet

The love affair started nine years ago when John Sweet bought his first Corvair for \$35. It was a 1965 "500" four-door. Naturally, he needed a second Corvair to fix up the first one. At one point, there were 14 Corvairs on John's roster.

Through the years, Corvairs have been a family affair with John. "My wife, Charlotte, helps me with the restoration work by doing the interiors. I do my own mechanical, body and paint work and my two children, Steve and Michelle, help me at swap meets selling parts."

The current Corvair Corral consists of a '66 Monza hard-top that Charlotte drives daily. This car has 102,000 miles on the original power train and is being readied for customizing. John drives a '69 "500" with 95 hp and a three-speed. It has a mere 22,000 actual miles on it. Hidden away and awaiting a ground-up restoration is a '66 Corsa convertible with a 180 Turbo engine.

Before moving to Pittsburgh, John was a member of the Corvair Club of Cincinnati, where he served as treasurer and president. He also belongs to the Corvanatics, the club for "95" series trucks. As you should know by now, John is also running for the board of directors for CORSA.

John has a side line...he services Corvairs and sells NOS and used Corvair parts. (Give him a call if you're having trouble finding parts. (412) 368-3922.

John says, "Happy Corvairing to you all."

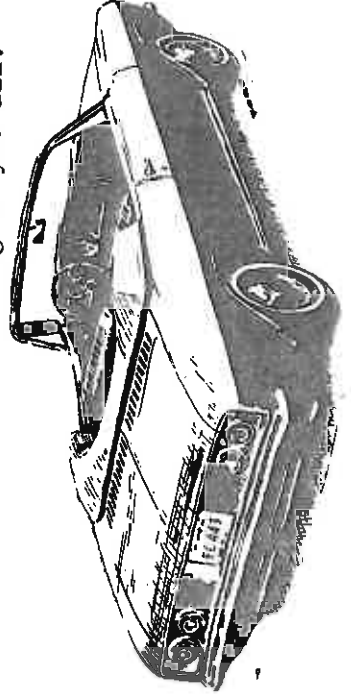

Next Event — Fourth of July

Celebrate the Fourth of July with WPCC and the Vintage Chevy Club at the Franklin High School Grounds in Murrysville.

The fun begins at noon and continues all day, climaxing with the fireworks display.

The afternoon will be spent at the Community Day festivities. Around 4:00 p.m. the fun moves to John and Carol Graf's home. John tells me he has lots of room...five acres. He has base pads, so bring your bats, balls and gloves. There's still plenty of room left for volleyball and badminton. If the weather's especially nice, you will be able to cool off in the pool. Take a hike in the woods if you like.

The picnic will be a covered dish affair. Please call Jan Fabyonic (327-7361) or Judy Jones (882-2109) by Friday, July 2, to let them know what you intend to bring—main dish, salad, vegetable, desert, etc. The club will provide soft drinks, beer and sandwiches of some sort.

Sometime before 10:00 p.m. we'll head back to the school grounds for the pyrotechnics. It should be a great day, so plan to be there.

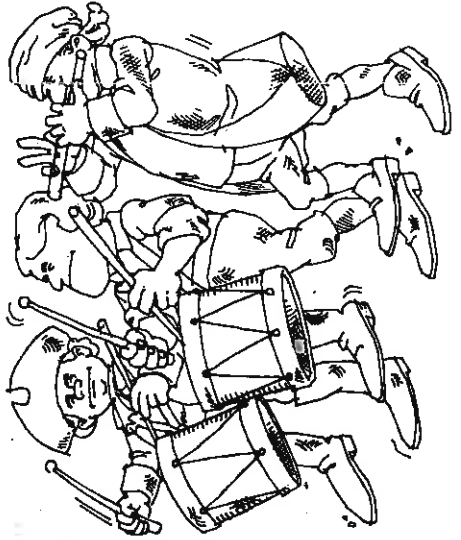

Coming Events

by Al Friend

- June 26 - 27 Connellesville, Pa. Coke ctr. Reg. AACA car show & flea mkt. Bullskin Twp. Fairgrounds. Rt. 982.
- June 27 Brookville, Pa. Kinzua Valley Reg. AACA show. Memorial Park.
- June 27 Monaca, Pa. Beaver Co. Car Club show, Community College Dome. Mike Yuran. (412) 843-2126, evenings.
- July 4 Vintage Chevrolet & WPCC show at Murrysville, Pa. Then picnic and pool party at John and Carol Graf's home.
- July 10 - 11 Iola, Wis. (Home of Old Cars Weekly) Car show and flea mkt. Krause Publications' grounds. Rt. 161, Iola, Wis.
- July 9 - 11 Pittsburgh Parts-A-Rama, Butler Fairgrounds, Rt. 422. Show 12 noon Sunday.
- July 18 Pittsburgh, Pa. North Hills Historic Auto Club's show and flea mkt. N. Hills Village Mall. Ted or Jean Hackett (412) 487-1911.
- July 28 - 31 CORSA National Convention, Syracuse, N.Y.

West Mifflin Auto Show Results

Congratulations to Bill and Jim Artzberger. Tiger I and Tiger II took second and third place in the special interest class. First place was taken by a van or was it a pickup truck?

The Gateway Clipper Parade

by Al Friend

WPCC helped the Gateway Clipper Fleet celebrate the move to their new docks on the South Side by participating in the land parade along E. Carson Street. At the same time, the entire fleet plowed the three rivers in a water parade. What a sight, from the South Side with the Golden Triangle in the background. Eight of our Vairs paraded together as a unit, and the others were drafted to haul celebrities. Pat Greenwald and the boys had a Pittsburgh Spirit soccer player, and Bill Artzberger almost had Franco Harris in Tiger II. Neal Spence and June Belkin ended up with politicians in their convertibles, I think.

At any rate, we all had a ball, and we all want to thank Jim Lane for once again arranging our appearance in a very prestigious event. I believe that Bill Brill and Archie Miller are still trying to get Jean and Alice out of the Freight House Shops at Station Square!

I am sorry if I miss anyone, but to my recollection, the following members participated: Pat Greenwald, Joe Scuro, June Belkin, the Morans, Brills, Millers, Artzbergers, Joneses, Spences, Lanes, Breiers and friends.

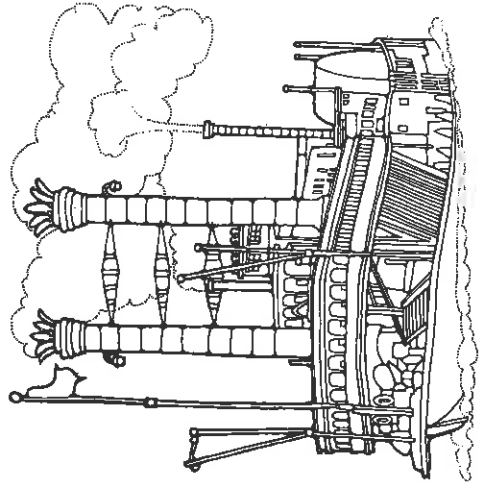

Highlights of Last Months Meeting

by Al Friend

Thirty members and their families had huge, delicious helpings of Italian food and even a pitcher or two of brown pop at Carbone's. We then caravanned a short distance to Bill and Jean Brill's home for dessert, coffee and, of course, the meeting. We finally got to see Ralph Roth's super clean 1960 blue Monza Coupe and Bill Ferrari's neat little Mini Cooper panel "truck." Special thanks to Bill for the Raffle engine rebuild. The engine will tentatively be raffled off at the Thursday evening barbeque at the national convention. Wayne Jones will be mailing raffle tickets to chapters.

Al Friend discussed the latest "Update" of the Legislative Council of Motor Vehicle Clubs of Pennsylvania. Because of the abuse of "Classic Plates", there is even a chance that they will be discontinued and recalled. Please talk to people whom you see abusing these plates. Perhaps we can police them to some extent, and hopefully save the plates.

Thanks to Bill and Jean for their tremendous hospitality.

Please see the Minutes of the Last Meeting (Page 1).

For Sale

65 Monza Sdn Low mileage, minimum rust, needs some work. Late model parts for sale...crossmember (complete) 4-speed trans. plus many other parts. John Sebbens 751-7771 eves.

65 "500" cp. auto, green/cream, bucket seats, p.b. radio, no rust, 30,000 original miles, never driven in snow. Offers around \$3,000 from collectors only. Eugene Atkins, 139 Glenfield Dr., Pittsburgh, Pa. 15235. (412) 793-4042.

A Mechanic's Plea

sent in by Isadore Krouse

Deliver me from knife-edged grills,
From cross-thread bolts and year-old bills;
From buried engines -- braised on top
And toggle actions without stop.

From chewed up bearings, sticky valves;
From shorted switch and frozen dowels;
Adjustment screws, all tucked away
Where never crept the light of day!

From service guides without a picture
And simplest things that need a fixture;
Locked cars to move without a key,
And little things I do for free.

From those who think antiques should run.
How can I repair what time hath done?
But most of all for this I pray:
To hold my temper one more day!!

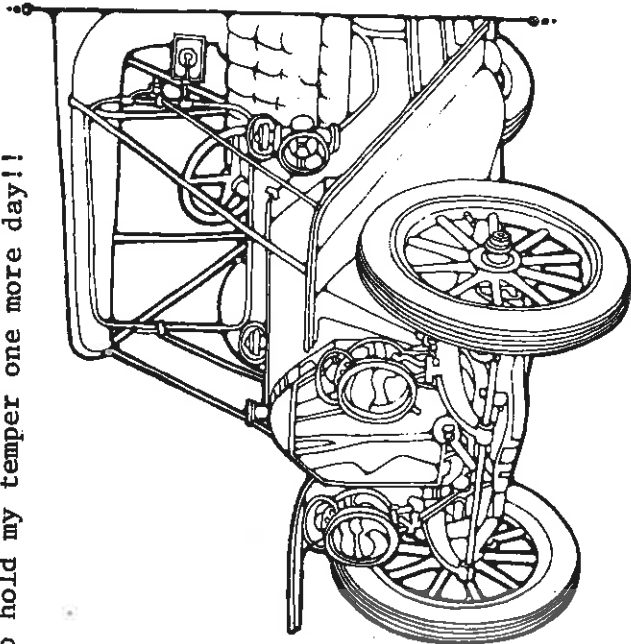

Corvair Society of America

Formed in 1969 by and for those who still appreciate the Corvair Automobile

CORSA MEMBERSHIP APPLICATION

CHECK ONE: NEW RENEWAL
RENEWALS

My name and address are correct as printed

Make the following corrections to my name and address:

(Please Print) Last Name _____ First _____

Address _____

City _____ State _____ Zip _____

Chapter _____ Chapter No. _____

City _____ State _____ Zip _____

Reason for joining CORSA _____

Activity Interest: _____

Age _____ Phone _____

Occupation _____

The following fee schedule includes your subscription to **CORSA COMMUNIQUE**, our monthly publication, for the number of months paid.

- 1 year U.S. membership - \$14
- 26 month U.S. membership - \$28
- 1 year Canadian membership - \$17
- 26 month Canadian membership - \$34
- 1 year Overseas membership - \$19
- 26 month Overseas membership - \$38
- Museum Fund Donation - \$1
- Racing Fund Donation - \$1
- Family membership - \$1

TOTAL: _____

U.S. FUNDS ONLY
MAKE CHECK PAYABLE TO
CORSA, INC.

CORVAIR SOCIETY OF AMERICA, INC.
P.O. Box 2488
Pensacola, Fla. 32503

MUSEUM FUND
A museum has been established to protect and preserve Corvair memorabilia. This fund has been established to perpetually finance the museum's growth and development.

RACING FUND
This fund provides cash prizes to winning Corvairs entered in national open class racing.

DO NOT WRITE IN BOX

Rec'd	_____
Amount	_____
Months	_____
Acct. No.	_____
Expires	_____

SURVEY OF CARS OWNED AND INTERESTS

- I own _____ running Corvairs.
- I own _____ restorable Corvairs.
- I own _____ parts Corvairs.
- I use my Corvairs for:
 - Concours - How Many? _____
 - Daily Use
 - Racing
 - Other _____
- My main reason for joining CORSA is:
 - Support my hobby
 - Fellowship
 - Increase the value of my investment
 - Magazine - "CORSA COMMUNIQUE"
 - To take part in () local/() national doings
- What I like to read most in my magazine is:
 - Technical Tips
 - Feature Articles
 - Convention information
 - CORSA governmental action
 - Open Forum
 - Chapter News
 - Local meet information



158
Western PA. Corvaair Club
3677 Forbes Trail Dr.
Murrysville, PA 15668

MEETING HELD
4TH TUESDAY
EACH MONTH
8:00 P.M.

GOOD SHEPHERD
LUTHERAN
CHURCH

OLD WM. PENN HWY.

RT. 48

SCHOOL

PGH.

PARKWAY BY-PASS

MONROEVILLE
EXIT

MURRYSVILLE

BUICK

PLUM EXIT

PGH.

BUS. RT. 22

MURRYSVILLE

HOWARD
JOHNSON'S

TURNPIKE
EXIT

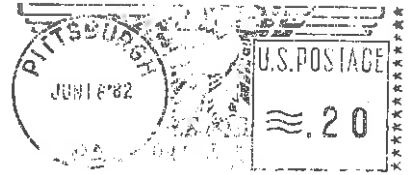

12/31/82B

KEY # 150

CHARLES-J LUCAS
236 MARIGOLD ST.
MUNHALL PA.

15120