

# THE VAIR STREET JOURNAL

WESTERN PENNSYLVANIA CORVAIRE CLUB

NOV/DEC. 1989

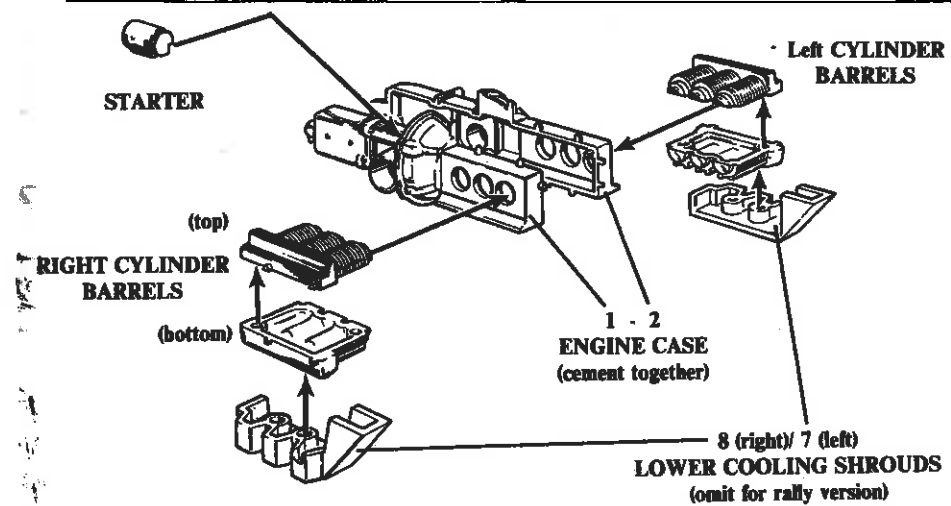

assembly instructions for  
the amateur mechanic

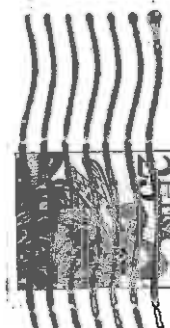
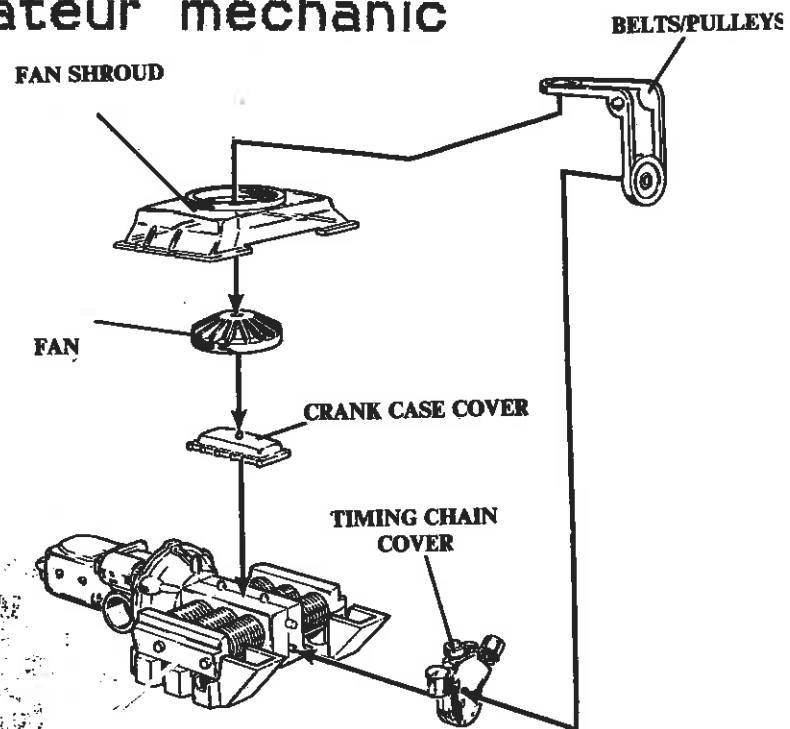

**THE WESTERN PENNSYLVANIA CORVAIR CLUB WANTS YOU!!  
MEMBERSHIP APPLICATION**

That sure is a great little car you're driving. In fact the Corvair is probably the most courageous, creative, and potentially the best engineered automobile to come out of Detroit in modern times. As you may already know, a two year study conducted by the U.S. Dept of Transportation, and suggested by Mr. Ralph Nader, concluded: "The Corvair quantitatively meets or exceeds standards set by contemporary automobiles in stability, cornering, and roll-over tests." It is also the only car ever proven safe in a court of law!!!

Next time a fellow Corvair driver waves to you, hold your head high and wave back, since you have something in common. "The Vair" however, is far from a common car. They are now quite rare, gaining in value, and have so many sensible features when compared to today's plastic and cardboard cars. Isn't it great *not* spending money on antifreeze and snow tires for example!

We are a chartered chapter of "The Corvair Society of America" (CORSA), a rapidly growing international organization now boasting over 8,000 members. We encourage all WPCC members to maintain membership in CORSAs—The International Corvair Club.

The long range goals of both clubs is simply to increase the enjoyment and preservation of the Corvair automobile. We provide - technical and historic information, parts procurement, professional publications, and an international classified ad service. We sponsor and participate in - Corvair shows, rallies, time trials, autocross events, mini conventions, and national conventions. We love driving to local points of interest, touring style, in Corvair convoys. We have parties, picnics, and dinners, there's always plenty of Corvair talk, and *all* of our events are family affairs. Our membership includes people from every imaginable age group, background, and profession. Our chapter provides a monthly newsletter, and CORSAs provides a beautiful monthly magazine named "The CORSAs Communiques."

We would love to welcome you, your family, and your Corvair into our club. Simply complete the attached application and mail it to Al Friend, WPCC Liaison. Remember, the nicest people drive Corvairs, and "You're Always Ahead With Your Engine Behind." Hope to see you soon.

**MEETINGS:** The 4th Tuesday of every month, 8 p.m. at the Good Shephard Lutheran Church, Monroeville, Pennsylvania.

**DUES:** LOCAL \$10 per calendar year or \$1 for each remaining month of the current year. Includes membership for immediate family members. *Payable to WPCC.*

MAIL TO: W.P.C.C. c/o J. DALE SMITH  
634 ARDEN LANE  
PITTSBURGH, PA  
15243

Name \_\_\_\_\_ Age \_\_\_\_\_ Occupation \_\_\_\_\_ Phone \_\_\_\_\_

Address \_\_\_\_\_ Zip \_\_\_\_\_ Date \_\_\_\_\_

CORSAs Member?  Yes  No. # Corvairs owned, yr., model \_\_\_\_\_

Recommended by \_\_\_\_\_ Amount paid \_\_\_\_\_ Other car clubs \_\_\_\_\_

Other information: \_\_\_\_\_

**MINUTES OF WPCC MEETING**

**OCTOBER 24, 1989**

1989 officers present: president, vice president, secretary, and treasurer.

1989 board members present: Bob McCune, Don Baker, Bob Hieber, Wayne Jones, Ray Horn, and Dick Breier.

The secretary's re-

port was approved as printed.

The treasurer's report was approved as read. There were 73 WPCC members in 1989.

Sharon and Mark Shmerin were guests of Bill Artzberger.

**Old Business**

Dick Breier reported on the tremendous success of the Hershey trip. He said we could've filled a trailer full of people wanting to go.

Al Friend said that the people on the bus thanked WPCC for the opportunity to go. They told him that our price was even \$3 cheaper than other bus trips to Hershey.

Bill Artzberger told the club that the White Post event was the nicest event he has ever been to. Unfortunately, it won't happen any more because it's just too expensive to produce. There were meals, live entertainment, and a battlefield re-enactment with field artillery, guns, horses, and cavalry.

More than 1000 cars were at White Post. The Pottstown Corvair Club was represented by about 15 cars.

Bob Ashworth said that White Post does an excellent job at re-sleeving wheel cylinders.

Jay Smith reminded us about the November 19 date for the Carnegie Museum tours and asks us to be there promptly at 1:15 PM.

Jay also reminded us of the Holiday Party on January 13, 1990 at Jimmies in downtown Pgh. Videos of 1989 WPCC events will be aired at the party. Please pay Irene by the November meeting.

Refreshments at the November meeting will be provided by Jean Larison and Carole Friend.

Bill Artzberger an-

nounced the 1990 Strasburg event will be held in the York area. Irene Atrzberger will notify us when Central PA. Corvair Club tells us where and when the event will be. We will know before the January meeting so we can include the event in our

### New Business

Al Friend showed us a copy of a magazine to which we can subscribe for \$8 per year. The magazine, *Awe-some*, contains listings of car related events. WPCC could advertise events in it.

Al reminded us that new officers will have to be nominated at the November meeting. Present club members will nominate new club officers.

Al suggested that we send a copy of this month's newsletter to those who attended the Titusville event.

WPCC voted on the renewal of our membership in the Legislative Council of Motor Vehicles for 1990. Motions were made by Vaun Hamlin to send \$35.00 dues and \$100.00 donation. Motions were seconded by Dave Fabyonic. WPCC agreed.

1990 calendar.

Don Baker reported on the Atlanta race with Corvairs in it.

Marie Dandois reported on the Marion Center car show with three Corvairs in it. Marie will let us know when the event is next year.

John Gundlach reported on the Slippery Rock Car Show. The cars were judged by a man who went to an AACA judging school.

Vaun Hamlin clued us in to a Taco Bell TV commercial with an early white Corvair in it.

Ray Horn reported on Herb and Gae Horn's experience with the earthquake in Santa Monica, CA. Gae was driving a car at about 50 mph when the quake hit and Herb was lounging beside the pool. After the quake was over, Herb found the water level in the pool to have dropped 14 inches from the sloshing. All in all, they were O.K.

Don Baker reminded the club about the November 8 SAE monthly seminar featuring Dave McClelland speaking on the ZR1 Corvette.

### The Gala Holiday Party January 13, 1990

Time to ring in a new decade of Corvairing with a very special get-together that should titillate the taste buds as we close out and fondly remember the eighties.

We have secured UP-OVER-JIMMIES on Smithfield Street. We will have a viewing area for all videos shot during the year, an open bar, and a world-class buffet following fruit and cheese hors d'oeuvre trays.

Now ladies, here's the neat part. Every year you want to see the holiday decorations and treat yourself to after the

holiday sales and the old boy says--"There's nothing to do." Now you've got him! Park in the garage at Smithfield and the Blvd. of the Allies and take in the sights. See the PPG complex, the courthouse, Oxford Centre, Benedum Center, all interconnected by the Subway which will get you back to Jimmies.

By the November meeting, we must have your paid reservation. The unbelievable cost is only \$10.00 per person, which covers buffet, tax, and gratuity!

Dale Smith

Remember... there will be NO December or January meetings at the Good Shepherd Lutheran Church. The January meeting will be held at the Holiday party on January 13, 1990. New officers will be elected at this meeting, so it is suggested that YOU BE THERE!

*Remember to reserve your place at the  
Holiday Party... See Irene Atrzberger  
at the November meeting.*

*Cost is only \$10.00 per person!  
Hope to see you there!*

### The Carnegie Museum Tours

Many thanks go to Dale and Ellen Smith for the guided tours of the Carnegie Museum. Not only was the tour fun, informative, and interesting, but it was also free! Three docents (tour guides) met us in the lobby at 1:30 and took three groups of WPC members through the museum. Two groups visited the Natural History section, and the other group learned of Mr. Carnegie's Legacy to Pittsburgh.

I found the Hillman Hall of Gems and Minerals to be the most fascinating. The wonders of the Earth send shivers up my spine. Al Friend was in my tour group video-taping everything. Be sure to see the replay at the upcoming Holiday Party. [No Al, I am not insinuating that you are a wonder of the Earth and send shivers up my spine.]

Someone (who shall remain nameless) commented on some of the works he saw displayed in the museum of art after the guided tours were over. The observer said there were some paintings there that he "wouldn't put under his Corvair to catch oil drippings!" Perhaps someone should try that...it might be worth a million dollars!

Those attending this event were Ellen, Jay, and Dale Smith; John and Gayle Gundlach; Bill, Irene, Jim, and Mary Artzberger and Sandy Burrows; Bob and Donna Hieber; Jan Abramson; Al and Carole Friend and Ann Glass; Walt and Boots Baldinger; Jean Brill; Ray Horn and friends; Bob and Jean Larison; Jim and Linda Mileski; Don Baker; and Yours truly.

Afterward, at about five o'clock, the Hiebers, Smiths, Ray Horn and friends, and I met at the Ground Round restaurant in Greentree. Everyone ate, drank and became merry. And if I hadn't seen it, I wouldn't have believed it. I actually witnessed the infamous popcorn battles, a ritualist rite that displays all the fervor of the conquests of the Vandals and Visigoths. [If you don't know what that means, ask Jean Brill.]

Anyway, I had a great time and I speak for everyone who attended the event in saying that if you weren't there, you missed a great get-together.

Laurie MagWheels Maglietta

### Five Years Ago In The Journal

Thanks to the efforts of Bob McCune and Bill Artzberger back in 1984, WPC completed a fantastic bus trip to White Post, Va. Bob and Bill were given a round of applause at the meeting and it was suggested that WPC sponsor similar events to Carlisle or Hershey! Well, it took five years, but thanks to Dick Breier, we did just that in 1989.

The November '84 meeting featured a hands-on carburetor rebuilding demonstration by Herb Horn. Eight Corvair convertibles paraded beauty queens onto the field for the Carnegie Mellon homecoming game. John Cossey's famous yellow '64 Monza coupe was for sale, and Bill Artzberger offered a tech tip on the importance of keeping those engine vent doors working properly as cold weather approaches.

The highlight of this journal was a two-page, very interesting article about our easternmost member, John Getz, and his nine Corvairs. Finally, the 1984 Holiday Party was arranged by Archie and Alice Miller at the Valley Inn, up in the mountains. The cost was a very reas-

nable \$10.00 per person. Hey, all of you had better thank the Smiths and the Hiebers for giving us 0% inflation for the last five years! Federal Reserve chairman Alan Greenspan would like to consult with you folks!!

Al Friend

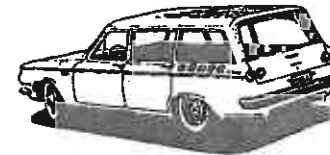

### The Prez Sez

Wow, this is my final Prez Sez since we have no meeting or Journal scheduled for December or January. We all get a couple of months to re-charge our personal batteries, so to speak. My fantastic team of officers and myself sincerely hope that everyone enjoyed WPC Corvairing 1989 style. We had a great time planning the events and tech sessions. Hopefully our efforts will pay future dividends many times over.

Thanks to the efforts of all of you, but especially treasurer, Irene Artzberger; and secretary, editor, and printer, Laurie Maglietta, we will

end 1989 in very good financial condition. What does this mean for WPCC Corvairing 1990 style? Well, for one thing, the 1990 officers and board will be able to consider and plan for upscale events without having to bet the club's survival on the turnout. Stand by, folks, for an interesting and fun-filled 1990, and hopefully for an interesting and fun-filled decade of the '90's.

Speaking of 1990, who's interested in leading us into the next decade? Nominations start at this meeting you know!! It might not be a bad year to take your turn as an officer. After all, several events are already in place, or will be early on. Carole and I will do the drags and another

Titusville-type cruise. I'm sure the Artzbergers will gladly do the Vintage races and perhaps a picnic type event, and I'll bet Dick Breier will do Hershey again! Jim Lane and Dave Moore will line up plenty of parades for us also. Hey, why isn't my phone ringing off the hook?

It's not too early to mention that the 1991 CORSA National Convention will be in the Washington D.C. area. They don't get any closer to us gang! Start now to work on whatever "needs done" on your show Vair.

In parting, I'd like to remind everyone that the deadline for paying for the January 13 Holiday Party is this meeting night.

Al Friend

### On the Road Again with the "Corvanatics"

Another long trip planned for Kermit, our 1964 Greenbrier Deluxe camper van, required some preventative maintenance. New hubs and universals in place, all four wheel bearings greased and new brake linings adjusted, took care of the running gear. The engine was renewed for a prior trip (Pittsburgh to San Jose, July, 1985). Tires looked good so all was ready.

Leaving San Jose, California, across the Golden Gate Bridge and up the coast to Eureka was somewhat disturbing with a vibration. That night the tires were rotated front to back and the next day the vibration went away.

The second day was great for 'Vairs, the twisting road through the Redwoods provided a good test for old Kermit! Then on through the mountains to Grants Pass, Oregon.

The third day was easy - through to Seattle and on to the Canadian border. A remark by the young Canadian border inspector startled us, "Do you think that old van will make it?" Kermit raced his engine and sped away! At the Dogwood Campground, Surrey, British Columbia, Kermit rested under the cool trees for four days while we walked our feet off at Expo. A side trip by Campground bus to Victoria was pleasant.

Transportation was the theme of Expo and was represented by auto, air, train, bus, and boat. The General Motors exhibit was great, with an Indian Spirit Lodge showing holograms and an old Indian with his magic canoe.

Time to leave Canada, and Kermit started right up for the trip south to Seattle for a two-day visit with a Navy flying buddy.

We drove through the Oregon Hills and Northern California Back Valley Country to the Mount Shasta KOA Campground at 4000 feet altitude. It was beautiful and clear, but cool at night.

The final day was Kermit's run for home and 100 degrees through the Sacramento Flatlands. At San Jose the mileage was 2,222 more and the oil used was 1 1/2 quarts. The gas was consumed at an average of 20.5 MPG.

Kermit is used everyday to commute and weekends for fun. We must admit to joining the "Part of the Month Club" though to keep Kermit on the road. If only a battery, or seatcovers, we end up doing something each month. We have found that a minimum of \$400 a year has to go into parts or tires to keep a vehicle "On the Road". Kermit now has 174,000 miles on the odometer. It is still the original camper as sold in 1964.

Gae and Herb Horn, Santa Clara, CA

## Corvair Classified

FOR SALE: '69 CROSSMEMBER. NEARLY NEW. ALMOST COMPLETE. \$150.00 364-6842. ASK FOR BILL.

FOR SALE: '68 COUPE. 110. GOOD BODY, CHROME, GLASS. SEE LEE PARKER.

FOR SALE: '63 CORVAIR CONVERTIBLE. AUTO. RESTORED 5 YEARS AGO. BEEN GARAGED SINCE. 74,000 MILES. NEEDS MUFFLER. \$4,000. OBO. SHARON OR MARK SCHMERIN 521-3013

FOR SALE: '69 MONZA CONVERTIBLE. MARINA BLUE/WHITE TOP. 47,811 MILES. 110/AUTO. RADIALS, WIRE BASKET WHEELS. ALSO: '66 CORSA 140/4 SPD. VERY FAST. BLACK/BLACK/WHITE TOP. RED CARPET, WOOD WHEEL, RADIALS, SPINNER CAPS. 87,000 MILES. JOHN & DOLLY LANTZ (FLA) (904) 238-2508 OR OHIO FROM DEC. 5 TO JAN. 2 (614) 498-6176. \$3,500.00 EACH.

FOR SALE: 2 BIAS PLY SNOW TIRES 7.00/C78-13, LIKE NEW, MAKE OFFER. 563-4047.

FOR SALE: 1964 4 SPD TRANSAXLE COMPLETE. \$30.00 457-9712.

FREE IF YOU PICK UP: 1964 110 ENGINE AND STD BELLHOUSING. NO IDEA OF CONDITION. 457-9712.

FOR SALE: 1966 3 SPD TRANSAXLE. COMPLETE. \$30.00. 457-9712.

FOR SALE: 1964 BUCKET SEATS. RED. FAIR COND. \$10.00. 457-9712.

WANTED TO BUY: 1965 OR 1966 BENCH SEAT FOR 500 2 DOOR. COLOR NOT IMPORTANT. PRICE MUST BE REASONABLE. 457-9712.

FOR SALE: LOTS OF 1964 CORVAIR CONVERTIBLE PARTS INCLUDING COMPLETE RED INTERIOR IN MINT CONDITION. BEST OFFER. 561-7919.

FOR SALE: CORVAIR VAN WITH SIDE DOOR. 4 CYLINDER. 4 SPD TRANNY. LOW MILBAGE (3000 ON ODO.) \$395.00 CALL CAROL AT (412) 845-8917 (VANDERGRIFT).

## PERSONALIZED LICENSE PLATES

(with up to 7 digits)

Effective February 27, 1989, the Bureau will accept and process applications for personalized plates with up to seven characters.

All requests must be submitted to the Bureau on form MV-904 (from a notary) with a twenty dollar check made payable to the Commonwealth of Pennsylvania.

These applications will be processed on a first come, first served bases, with an expected delivery date of 8 to 10 weeks.



Otto Mechaals

By Jay Piersanti

